

# MARINE PRODUCTS EQUIPMENT GUIDE

## Volume IV



**ERL COMMERCIAL MARINE INC.**

**SECTION  
01**

**CARGO GAUGING PRODUCTS**

**SECTION  
02**

**OVERFILL PROTECTION PRODUCTS**

**SECTION  
03**

**VENTING PRODUCTS**

**SECTION  
04**

**BARGE CONNECTION**

**SECTION  
05**

**MARINE PRODUCTS**

**SECTION  
06**

**FABRICATION PRODUCTS**

**SECTION  
07**

**PUMP PRODUCTS**

**SECTION  
08**

**REFERENCE INFORMATION**

**PHONE:1-812-948-8484 | FAX:1-812-944-8808**

**EMAIL: ERLSALES@ERLINC.NET | WEBSITE: WWW.ERLMARINE.COM**

**COPYRIGHT @ 2017**

**ANY REPRODUCTION OF THIS CATALOG AND ITS CONTENTS WITHOUT THE PERMISSION OF THE PUBLISHER IS STRICTLY PROHIBITED.**



**COMMERCIAL  
MARINE INC.**

*Mailing:*

**PO BOX 1026  
NEW ALBANY, IN 47151-1026**

*Shipping:*

**2560 CHARLESTOWN ROAD  
NEW ALBANY, IN 47150**

# ERL MISSION STATEMENT

Electromechanical Research Laboratories was founded in 1970 with a simple mission, to follow the Golden Rule. Simply stated, it is to treat others in the way that we want to be treated. This simple rule continuously guides our behavior toward our customers, our employees, and our vendors.

## FOREWORD

Dear Marine Industry Associate:

ERL Commercial Marine, Inc. is proud to provide you with our fourth edition of our Marine Equipment Guide. We hope you will find this book to be a valuable reference tool that you will want to use often.

Since the founding of ERL, Inc. in 1970, by Dr. Larry Wilkins, our company has been guided by old fashioned values and today's leading technology. We maintain our old fashion values producing quality products, service, and integrity in customer relations along with high tech design regarding engineering, testing and manufacturing methods. Our 50,000 square foot manufacturing facility produces equipment ready for the demanding marine workplace environment. It all adds up to VALUE for you.

Everyone at ERL, Inc. appreciates your business. We thank you for allowing us to install ERL marine equipment on over 10,000 of your liquid cargo compartments! The positive evolution of our equipment is a continuing effort. We want to know what we can do to service you better. If you have comments or questions concerning this book or any of the products listed, please do not hesitate to call.

Thank you!

Sincerely,

**Dr. Larry C. Wilkins**  
CEO

**Stephen Wilkins**  
President

**Todd Marshall**  
Plant Manager

**Ryan C. Waiz, PE**  
Design Engineer

**Billy Swartz, Houston**  
**Allen Pfaadt, New Orleans**  
**Mark Matheny, New Albany**  
**Ron Monell, Pensacola**  
Technical Sales and Business  
Development

**Dale Popp**  
Production/Quality  
Assurance



# ERL INC.

**MANUFACTURING EXCELLENCE  
FOR OVER 45 YEARS!**

## MACHINING

ERL has 3, 4, or 5 axis CNC machining for all types of materials including: Steel, Stainless Steel, Cast Iron, Aluminum and Bronze. ERL utilizes the latest DMG MORI CNC manufacturing technology as well Siemens NX CAD/CAM technology.

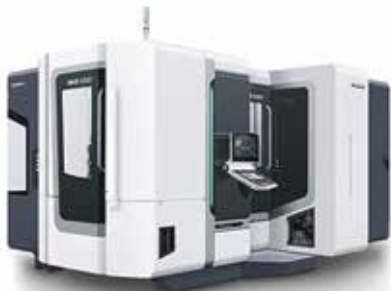

**DMG Mori NHX 6300.** 4 Axis horizontal mill 50 taper with pallet changer. 41" x 35" x 41"



**HAAS UMC 750.** 5 Axis vertical mill 40 taper. 30" X 20" x 20"



**HAAS VF5/50.** 3 Axis vertical mill 50 taper. 50" X 26" x 25"



**DMG Mori NLX 2500 sy/700.** Dual spindle lathe with live tooling and y axis. 14" dia x 28" length



**HAAS VF6/50.** 3 Axis vertical mill 50 taper. 64" X 32" x 30"



**HAAS SL40.** Lathe with live tooling. 25.4" Dia x 44" length



**HAAS VF2/40.** 3 Axis vertical mill 40 taper. 30" x 16" x 20"

## QUALITY CONTROL

ERL has the highest quality and largest capacity CMM capability. Ensuring that your parts are made to meet or exceed your specifications.



**Shelton (Renishaw control).** CMM. 118" x 59" x 47"



**Hexagon 4.5.4.** CMM. 15" x 19" x 15"



ERLSALES@ERLINC.NET  
812.948.8484

Manufacturing  
Square Feet = 50,000

# FABRICATION

ERL has incredibly efficient laser, welding and forming equipment for materials such as: Steel, Stainless Steel, Aluminum and Bronze. ERL offers MIG, TIG and Spot welding in a variety of thicknesses and materials.

## EXAMPLE PARTS



Machined 17-4Ph Stainless Shaft



Fabricated Stainless Steel Assembly

Machined 20" Carbon Steel Drum

Stainless Steel Bearing Retainer



Cincinnati CL800. Sheetmetal laser. 5' x 10'



Cincinnati CL707. Sheetmetal laser. 5' x 10'



Cincinnati 90mx Maxform. Pressbrake 45 ton. 100"



Omax 2652. Waterjet. 52" x 26"



Lincoln Fanuc 100i. 6 axis robotic welder. 54" reach



**SECTION****01****CARGO GAUGING PRODUCTS**

REPRINT OF 46 CFR PART 39 Subpart 39.20 .....	3
8" ROUND SCRAPER SIGHT GLASS.....	4
4" ROUND SIGHT GLASS .....	5
FULL VIEW MODEL SGM-1™ .....	6
FULL VIEW MODEL SGM-2™ .....	14
ERL MODEL SGMRD-8™ .....	15
RADIAL ARM GAUGE TREE™ .....	17
VHSG(TM) VENT HEADER SIGHT GLASS .....	21
RSA-LEVEL ALERT RISING STICK ARM.....	23
MODEL DS-39 RISING STICK GAUGE.....	24
DRAFT MARKS .....	31
HIGH LEVEL/OVERFILL TABS .....	31
SAMPLER BALL VALVES.....	32
PORTABLE GAUGING SYSTEMS.....	32
VAPOR CONTROL VALVES.....	33
FLEXI-DIP .....	33

**SECTION****02****OVERFILL PROTECTION PRODUCTS**

EXCERPTS FROM FEDERAL REGISTER.....	38
API RECOMMENDED PRACTICE 1125 .....	41
HIGH LEVEL/OVERFILL LIQUID LEVEL ALARM SENSORS .....	43
BARGE TO SHORE CONNECTION BTS ASSEMBLY DRAWINGS .....	52
TYPICAL SERIES WIRING DIAGRAMS.....	53
PORTABLE ALARM PANEL MODEL APM-1B LITE.....	57
PORTABLE ALARM PANEL MODEL APM-1B .....	58
PORTABLE ALARM PANEL MODEL APM ITLB.....	59
FIXED ALARM PANELS APM-2 .....	60
APM-2-F-APA ANTI POLLUTION ALARM.....	66
APM-2-E FIXED ALARM PANEL .....	71
APM-3 .....	72
SUPERAC™ 12" ROUND MARINE SAFETY RELIEF VALVE .....	73

**SECTION****03****VENTING PRODUCTS**

EXCERPTS FROM FEDERAL REGISTER.....	78
HIGH VELOCITY PRESSURE/VACUUM RELIEF VALVE .....	79
DESCRIPTION OF THE PV-6 II.....	80
OPERATION OF THE PV-6 II .....	82
TESTING OF THE ERL PV-6 II.....	83
SUPERAC(TM) MODEL PV-6 II.....	84
PV-6 II PERFORMANCE.....	86
EQUATE(TM) SERIES 2.5" PV VALVE.....	88
EQUATE(TM) SERIES 4" PV VALVE .....	92
EQUATE(TM) SERIES 8" PV VALVE .....	96
MARINE FLAME SCREENS .....	100
PROTECTED FLAME SCREEN VENT (EPV).....	101
VENT STACK.....	102

**SECTION****04****BARGE CONNECTION**

STAINLESS 40 TON WINCH – 100" CAPACITY – TANK BARGE.....	104
STAINLESS 40 TON WINCH – 50" CAPACITY – TANK BARGE.....	105
STAINLESS 40 TON WINCH – 50" CAPACITY – HOPPER BARGE .....	106
BOLT ON WIRE SWAGE HOLDER.....	107
BOLT ON WIRE ROPE BUTTON EWB-1 .....	108
DESCRIPTION OF THE 40 TON WINCH .....	109
KEY DESIGN FEATURES.....	110
40 TON WINCH OVERALL DESIGN DIMENSIONS.....	111
40 TON WINCH OPERATING INSTRUCTIONS .....	112

**SECTION****05****MARINE PRODUCTS**

MARINE SCUPPER PLUG.....	114
DECK STANDS .....	115
SUPERSEAL™ REACH ROD STUFFING BOX.....	117
SUPERSEAL™ STUFFING BOX.....	119
CARGO VALVE POSITION INDICATORS.....	121
CONTROL VALVE OPERATING SYSTEM.....	123
REACH RODS .....	124
STEM ADAPTERS .....	126
HANDWHEELS .....	127
ROD-TO-ROD COUPLERS .....	128
SHAFT HANGERS.....	129
YOKES .....	130
REGULATORY SIGNS .....	132
MARINE CAM HANDLE SCUPPER PLUG .....	140
LIP SEAL STUFFING BOXES .....	141
U-JOINT .....	142
DECK STAND – LASER ALIGNMENT TOOL KIT .....	143
STUFFING BOX – LASER ALIGNMENT TOOL KIT INSTALLATION .....	144
PRESSURE/VACUUM VIBRAGUAGE.....	145

**SECTION  
06****FABRICATION PRODUCTS**

OVERFLOW TANK .....	148
DRY BOX – PIPE MOUNT.....	149
CARGO CLEANING DIFFUSER .....	150
THROTTLE CONTROL HANDLE .....	151
DRY BOX.....	152
CARGO PUMP CATCH CAN.....	153
DRIP PANS .....	154
VENT STACK .....	155
LADDERS .....	156
FUEL TANKS .....	159
BARGE SPILL KIT RACK.....	160
MARINE SCUPPER PLUG .....	161
DOCUMENT BOXES.....	162
FIRE EXTINGUISHER HOLDERS.....	163
HOSE RACK .....	164
AIR BOX DRAIN CANISTER.....	165
TELESCOPIC PEEP LIGHT .....	166
TANKERMAN'S SHED .....	167

**SECTION  
07****PUMP PRODUCTS**

12LS DEEPWELL VERTICAL TURBINE TANK BARGE PUMP .....	170
10LS DEEPWELL VERTICAL TURBINE TANK BARGE PUMP .....	171
12LS OFFSHORE BALLAST WATER VERTICAL PUMP .....	172
10LS AND 12LS BARGE PUMP DESIGN .....	173
10LS AND 12LS BARGE PUMP TESTING .....	175
10LS AND 12LS BARGE PUMP PERFORMANCE.....	177
PUMP PURCHASE REQUISITION .....	179
ERL FOUR SCREW VERTICAL TANK BARGE PUMP.....	180
MECHANICAL SEAL.....	181
SHAFT COUPLING.....	183
OUTER BEARING ASSEMBLY SLEEVED (OBAS).....	185
OUTER BEARING ASSEMBLY FIXED (OBAF).....	187
OUTER BEARING ASSEMBLY (OBA) .....	189
COMPANION FLANGE .....	191
DRIVESHAFT-PTO TO RIGH ANGLE DRIVE.....	192
DRIVESHAFT-LASER ALIGNMENT TOOL KIT.....	193
APM-2F-APA ANTI POLLUTION ALARM .....	194

**SECTION  
08****REFERENCE INFORMATION**

CARGO GRADES.....	196
CONVERSION FACTORS.....	197
MARINE TERMS AND DEFINITIONS .....	198
BARGE SYSTEMS, PARTS AND FIELD SERVICE.....	208
ERL VAPOR RECOVERY TRAINING BARGE.....	209
INDEX.....	210



**SECTION  
01**

# CARGO GAUGING PRODUCTS



**8" Round Scraper Sight Glass**

pg 4



**4" Round Sight Glass**

pg 5

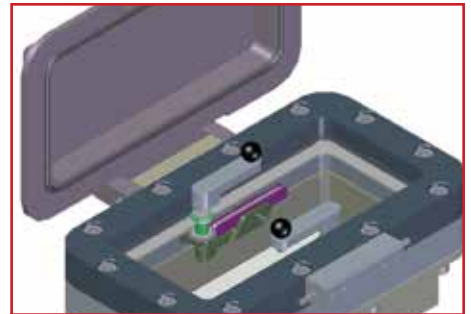

**Full View SGM-1 Marine Sight Glass**

pg 6

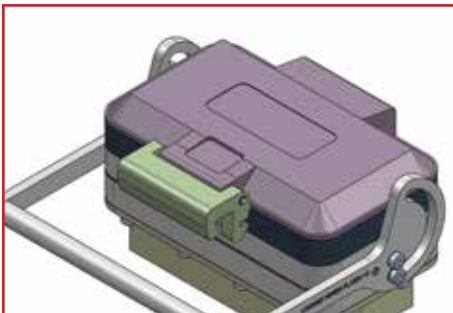

**Full View SGM-2 Clamshell Marine Sight Glass**

pg 14



**8" Round Sight Glass SGMRD-8™**

pg 15



**Radial Arm Gauge Tree™**

pg 17



**RSA - Rising Stick Alarm**

pg 23



**DS-39™ Rising Stick Gauge**

pg 24

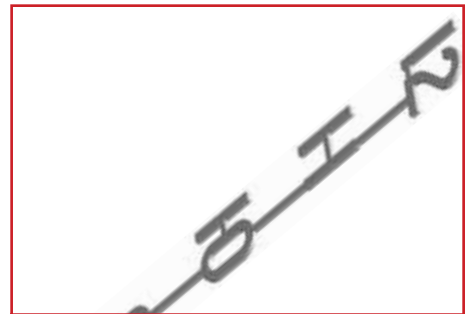

**Draft Marks**

pg 31



**Overfill Tabs**

pg 31



**Portable Gauging**

pg 32



8" Round Scraper Sight Glass.



FULL VIEW MODEL SGM-1™ Sight Glass - mounted on expansion dome.

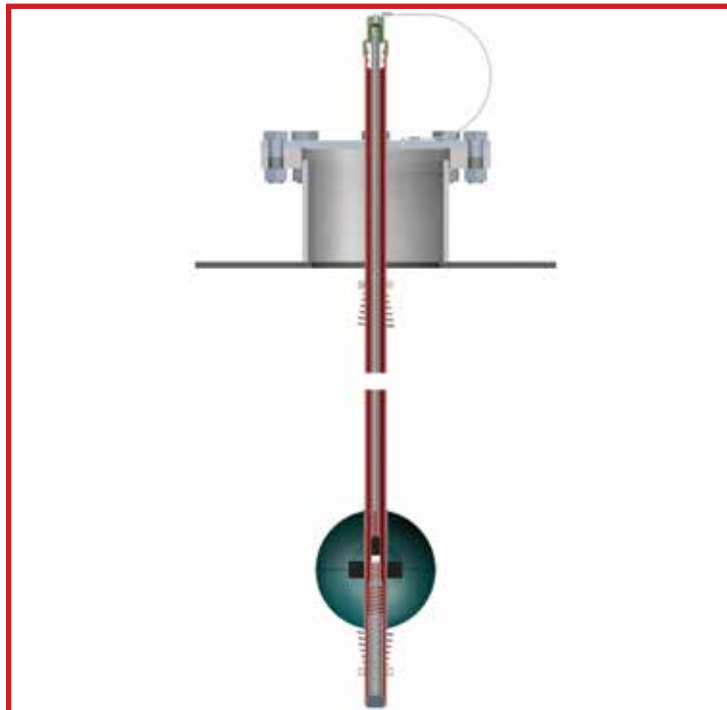

Rendered view of the DS-39 Rising Stick Gauge.



FULL VIEW MODEL SGM-1™ Sight Glass - weather cover closed - mounted on expansion dome.



## EXCERPTS FROM FEDERAL REGISTER

PART II - Dept. of Transportation - Coast Guard - June 21,1990  
46CFR Part 39 Vapor Control Systems  
Subpart 39.20 Design and Equipment  
§ 39.20-3 Cargo gauging system -TB/ALL

**The following section, reprinted here for your convenience, contains the USCG rules and regulations regarding cargo gauging systems.**

### 39.20-3 Cargo gauging system-TB/ALL

- (A) Each cargo tank of a tank vessel that is connected to a vapor collection system must be equipped with a cargo gauging device which:
- (1) Provides a closed gauging arrangement as defined in Sec. 151.15.10 of this chapter that does not require opening the tank to the atmosphere during cargo transfer; "The Full Model View SGM-1 Marine Sight Glass satisfies this requirement."
  - (2) Allows the operator to determine the liquid level in the tank for the full range of liquid levels in the tank; "The Radial Arm Gauge Tree satisfies this requirement."
  - (3) Indicates the liquid level in the tank at the location where cargo transfer is controlled; and
  - (4) If portable, is installed on the tank during the entire transfer operation.
- (B) Except when a tank barge complies with Sec. 39.20-9(a) of this part each cargo tank of a barge must have a high level indicating device that: "The DS-39 Rising Stick Gauge satisfies this requirement."
- (1) Provides a visual indication of the liquid level in the cargo tank when the cargo level is within 1.0 meter (3.28 feet) of the tank top;
  - (2) Has the maximum liquid level permitted under 39.30-1(e) of this part at even keel conditions conspicuously and permanently marked on the indicating device; and
  - (3) Is visible from all cargo control areas on the tank barge.

## 8" ROUND SCRAPER SIGHT GLASS



- **DO YOU HAVE ISSUES WITH WIPING CRUDE OIL OR STYRENE?**  
The ERL Model SGMRD-8 Scraper model uses an innovative 17-4PH Stainless Steel Hardened and Coated Scraper to remove even the toughest of grit on your Sight Glass.
- **FULL REGULATORY COMPLIANCE WITH 46 CFR PART 39 PARAGRAPH 39-20-3(a)**  
The ERL Model SGMRD-8, 8" round marine sight glass complies with U.S. Coast Guard regulations and is suitable for use on all liquid cargo vessels.
- **ROUND 56 SQUARE INCH VIEWING AREA**  
Mounted adjacent to each cargo valve control handwheel, the ERL Model SGMRD-8 gives the tankerman a 56 square inch round viewing port into the compartment without exposure to potentially hazardous vapors.
- **1/2 INCH THICK GROUND AND POLISHED BOROFLOAT™ GLASS**  
Each 8.5" diameter BOROFLOAT™ glass is fully stress relieved with ground edges. The top face of the glass is above the stainless steel frame to prevent water pooling when used during rain.
- **SOLID CONSTRUCTION AND EASY MOUNTING**  
The ERL Model SGMRD-8 is constructed from 300 series stainless steel and mounts to any standard 8" 150 lb. class mounting flange, having (8) 0.88" diameter holes on a 11.75" diameter bolt circle.



## 4" ROUND SIGHT GLASS



- **FULL REGULATORY COMPLIANCE WITH 46 CFR PART 39 PARAGRAPH 39-20-3(a)**  
The ERL Model SGMRD-4, 4" round marine sight glass complies with U.S. Coast Guard regulations and is suitable for use on all liquid cargo vessels.
- **ROUND 13 SQUARE INCH VIEWING AREA**  
Mounted directly on top the vapor header, the ERL Model SGMRD-4 gives the tankerman a 13 square inch round viewing port into the compartment without exposure to potentially hazardous vapors.
- **1/2 INCH THICK GROUND AND POLISHED BOROFLOAT™ GLASS**  
Each 4.5" diameter BOROFLOAT™ glass is fully stress relieved with ground edges. The top face of the glass is above the stainless steel frame to prevent water pooling when used during rain
- **SOLID CONSTRUCTION AND EASY MOUNTING**  
ERL Model SGMRD-4 is constructed from 300 series stainless steel and mounts to any standard 4" 150 lb. class mounting flange, having (8) 0.750" diameter holes on a 7.50" diameter bolt circle.

## FULL VIEW MODEL SGM-1™



U.S. PATENT  
NO. 5,284,105

- **FULL COMPLIANCE WITH 46 CFR PART 39, Para. 39-20-3(a)**  
The FULL VIEW MODEL SGM-1 Marine Sight Glass is the tank barge industry standard for vessel operators complying with U.S. Coast Guard Regulations 46 CFR PART 39, Paragraph 39.20-3(a) and is suitable for use on ABS classed vessels.
- **FULL 59 SQ. IN. OF VIEWING AREA**  
Mounted adjacent to each cargo compartment control valve, the FULL VIEW MODEL SGM-1 provides the largest and clearest view into your cargo compartment available with a full 59 square inches of viewing area, without exposing personnel to hazardous vapors.
- **EASILY REPLACED WIPER BLADES**  
Dual wipers clean the cargo side of the BOROFLOAT™ glass. The wiper blades are easily replaced in the field, and are available in a variety of materials for maximum cargo compatibility. The FULL VIEW MODEL SGM-1 is available with Teflon™, EPDM and Viton wiper blade refills.
- **3/4" THICK GROUND AND POLISHED BOROFLOAT™ GLASS**  
Each glass is fully stress relieved with ground edges and radiused corners. Four built-in drain ports in the top glass flange prevent water pooling on the glass when the full weather cover is open.
- **SOLID CONSTRUCTION AND EASY MOUNTING**  
The upper and lower glass flanges are made of 1-1/2" thick stainless steel. The weather cover is made of cast aluminum and the standard deck mounting flange is made of stainless steel for easy weld-down to your deck.



## FULL VIEW MODEL SGM-1™ MOUNTING OPTIONS

### VERSATILE

ERL's exclusive separate deck mounting flange simplifies mounting and reduces the risk of glass damage during installation. The drawings below show various mounting arrangements. Teflon™ gaskets are furnished as standard and other gasket materials are available.

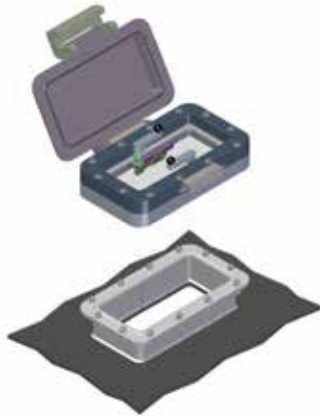

Once the weld-down deck flange (included) is welded to the deck using 1/8" diameter welding rod at 125 amps the FULL-VIEW MODEL SGM-1 is ready to bolt in place. A Teflon™ gasket and 12 stainless steel mounting bolts are included.

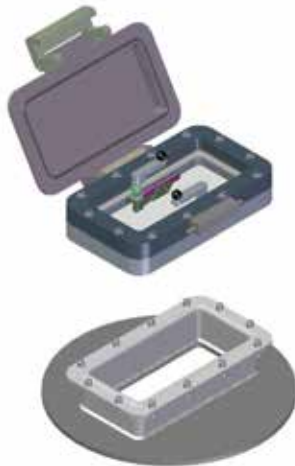

FULL-VIEW MODEL SGM-1 shown with Adapter Plate (mounting flange attached) designed for ready installation on a standard 24" riser.



FULL-VIEW MODEL SGM-1 shown with weather cover closed.

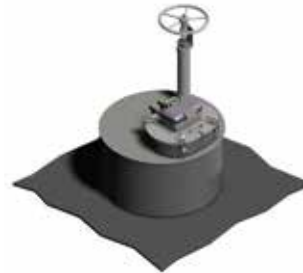

FULL VIEW MODEL SGM-1 installed on the raised water-tight hatch located on an expansion trunk. A hatch backstop is recommended on this style of installation.



FULL VIEW MODEL SGM-1 installed directly on the expansion trunk.



FULL VIEW MODEL SGM-1 installed on a 24" pipe adjacent to the expansion trunk.

### FULL VIEW MODEL SGM-1™ PARTS DIAGRAM

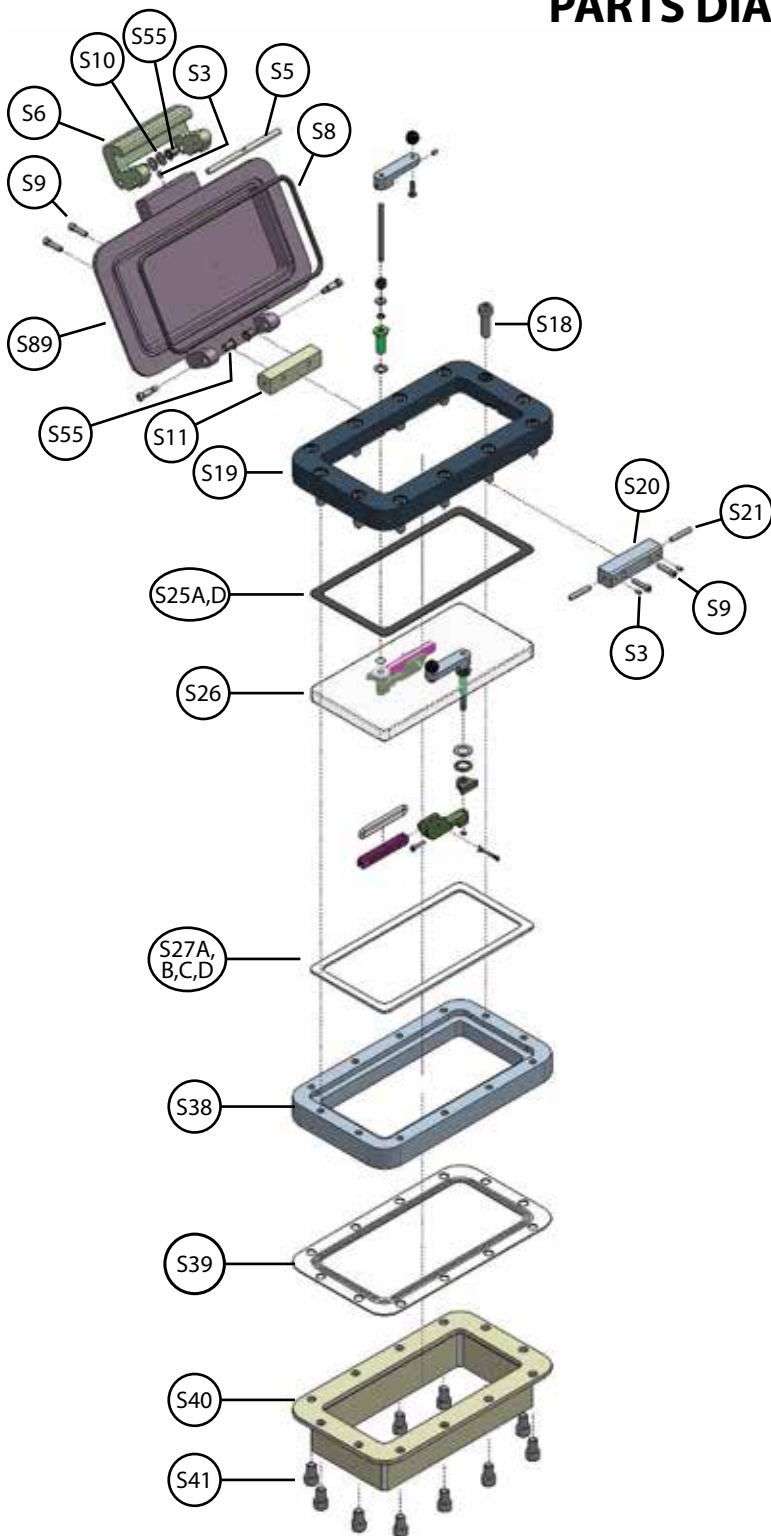

SGM-1 Parts List		
ITEM	DESCRIPTION	QTY
S1	Shoulder Bolt	1
S3	Set Screw 10-32 x 5/16	3
S5	Latch Shaft	1
S6	Latch	1
S8	O-Ring Gasket	1
S9	SHCS 1/4-20 x 1	4
S10	Washer	2
S11	Cover Hinge Block	1
S12	Shoulder Bolt, 1/4 x 3/8	2
S13	Knob	2
S14	Wiper Handle	2
S15	Wiper Shaft	2
S16	Spring	2
S17	Washer	1
S18	SHCS 1/2-20 x 1-1/2	12
S19	Top Flange	1
S20	Latch Pin Block	1
S21	Latch Pin	2
S22	O-Ring	2
S22C	O-Ring - Chemraz	2
S23	Bushing	2
S25A	Top Glass Seal	1
S25D	Top Glass Seal	1
S26	Glass	1
S27A	Bottom Glass Seal	1
S27B	Bottom Glass Seal	1
S27C	Bottom Glass Seal	1
S27D	Bottom Glass Seal	1
S28	Washer	4
S28S	Washer, Sealon	4
S32A	Wiper O-Ring (EPDM)	2
S32B	Wiper O-Ring (Viton)	2
S33	Wiper Cartridge	2
S37	C-Clip	2
S38	Bottom Flange	1
S39A	Unit Flange Gasket	1
S39B	Unit Flange Gasket	1
S40	Mounting Flange	1
S41	SHCS 1/2-20 x 3/4	12
S48	SHCS 10-32 x 3/4	2
S49	Wiper Arm	2
S50	Cotter Pin	2
S51	Flat Washer	2
S52	Belleville Washer	2
S53	Stop Nut	2
S55	Latch Bushing	4
S89	Cover	1





### FULL VIEW MODEL SGM-1™ & SGM-2™ PARTS REFERENCE INFORMATION

#### WIPER HANDLE ASSEMBLY

QTY.	ITEM#	DESCRIPTION
1	S3	Set Screw
1	S12	Shoulder Bolt
1	S13	Knob
1	S14	Wiper Handle
1	S15	Shaft
1	S16	Spring
1	S17	Washer
1	S22	O-ring
2	S37	C-clip

#### WIPER ARM ASSEMBLY

QTY.	ITEM#	DESCRIPTION
1	S32	O-Ring
1	S33	Wiper Cartridge
1	S48	SHCS 10-32 x 3/4
1	S49	Wiper Arm
1	S50	Cotter Pin

#### WIPER BUSHING ASSEMBLY

QTY.	ITEM#	DESCRIPTION
1	S23	SS Bushing
2	S28	Teflon Washer
1	S51	Flat Washer
1	S52	Belleville Washer
1	S53	SS Stop Nut

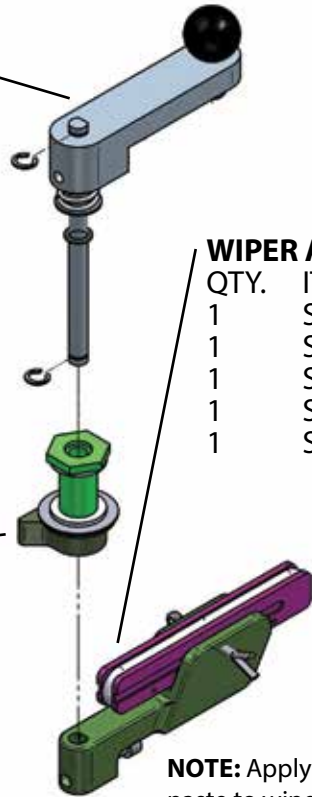

**NOTE:** Apply (Rector Seal T Plus 2) Teflon™ paste to wiper shaft #15 and Teflon™ bushing washers #28 during assembly.

### WIPER HANDLE ASSEMBLY

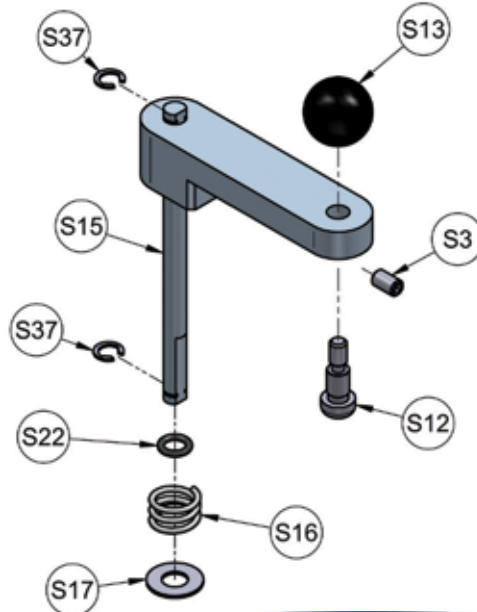

### FULL VIEW MODEL SGM-1™ REFERENCE INFORMATION

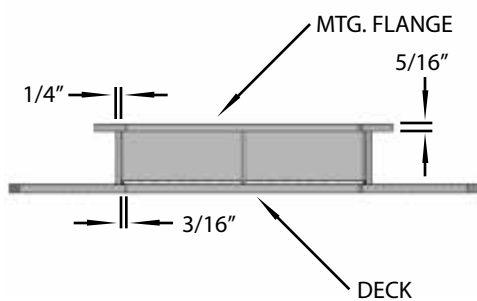

Standard stainless steel weld-down mounting flange.

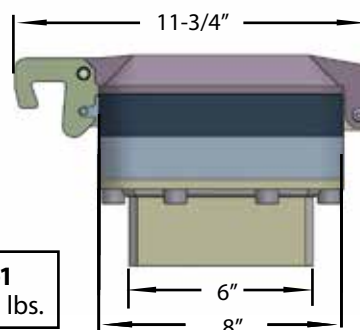
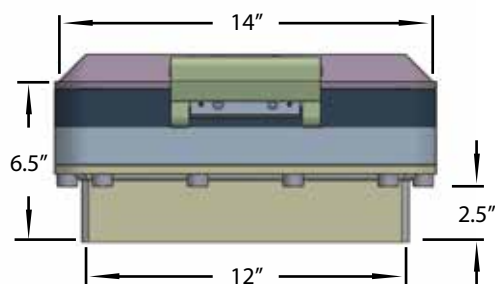

**SGM-1**  
WT. = 65 lbs.

### OPTIONS

#### UPPER GASKETS

**Standard:** Neoprene

**Optional:** Buna N, Viton, EPDM, Garlock

#### LOWER GASKETS

**Standard:** Teflon™

**Optional:** Buna N, Goretex, Graflex, EPDM, Viton, Others on request.

#### WIPERS

**Standard:** Teflon™

**Optional:** EPDM, Viton, Butyl, Buna N or any standard #328 O-ring.



Full-View Model SGM-1 installed on an expansion dome adjacent to the valve shut-off and access cover.

Glass can be ordered without holes.

Replacement glass and wiper arm assembly.





### FULL VIEW MODEL SGM-1™ & SGM-2™ PARTS REFERENCE INFORMATION

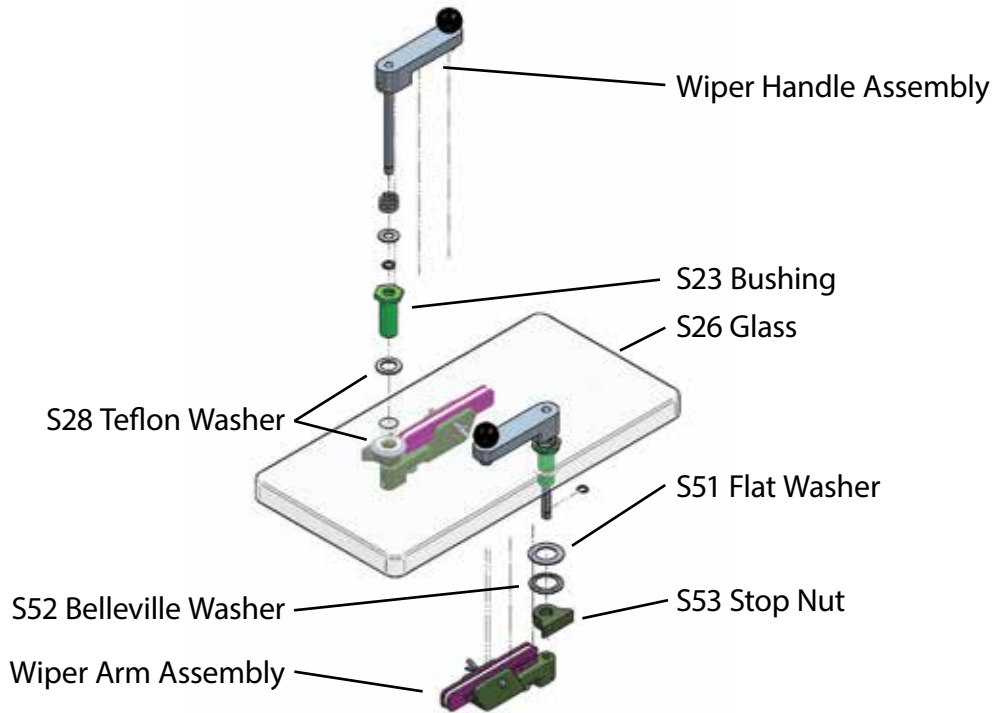

### WIPER ARM ASSEMBLY

**Standard:** Teflon™

**Optional:** EPDM, Viton , Buna N or any standard #328 O-ring.

**NOTE:** The Wiper “blades” utilize standard thickness and diameter O-rings universally referred to as size #328. Teflon™ replacement wiper blade material P/N S-32-C is available in 15 foot long spools.

QTY.	ITEM#	DESCRIPTION
1	S32	O-Ring
1	S33	Wiper Cartridge
1	S48	SHCS 10-32 x 3/4
1	S49	Wiper Arm
1	S50	Cotter Pin

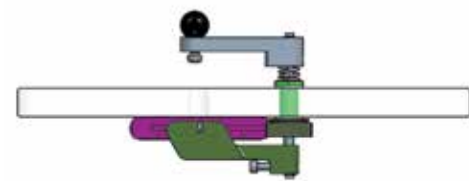

Detail view of wiper installed.

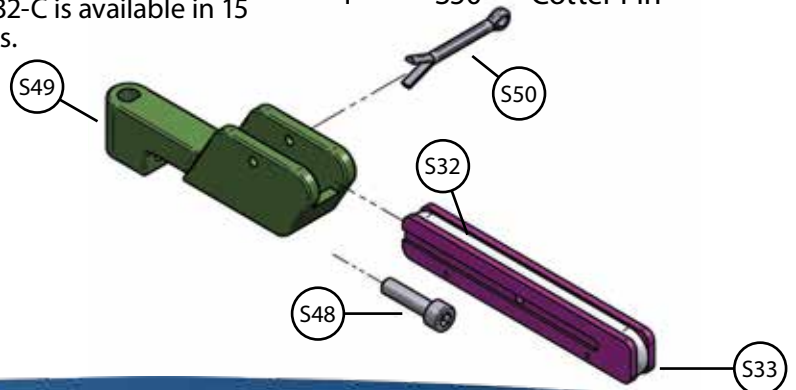
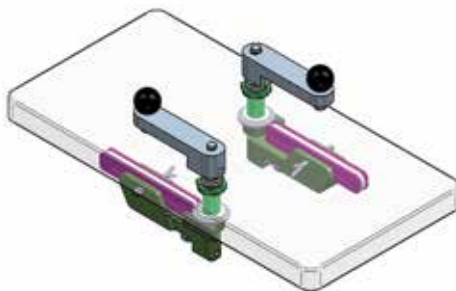

### FULL VIEW MODEL SGM-1™ DECK FLANGE WELDING PROCEDURES

#### STEP 1 TACK WELDS

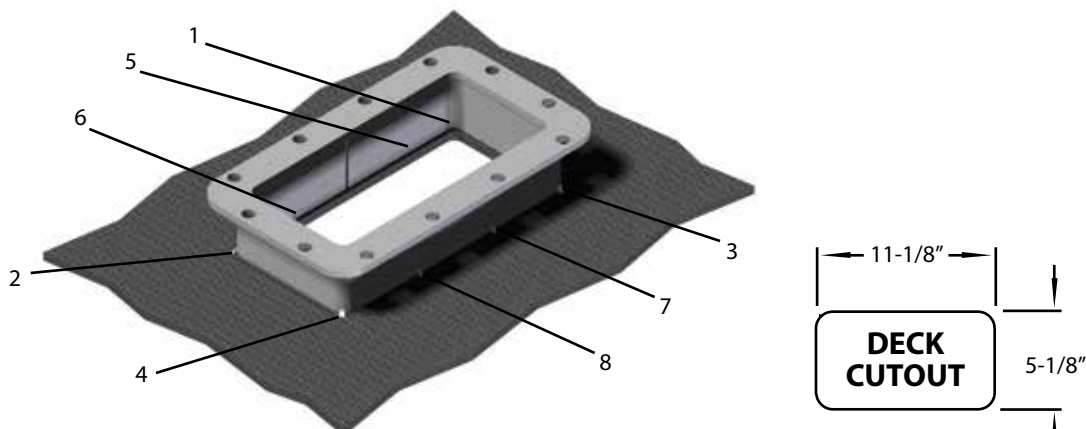

\* Please use 1/8" dia. welding rods with welder set to approximately 125 amps.

\* For MIG use 0.045 wire at approx. 190 amps.

#### STEP 2 INSIDE WELDS

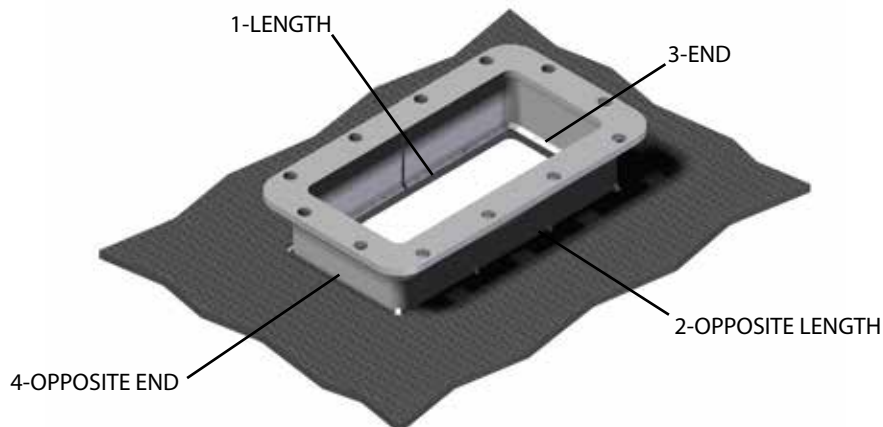

#### STEP 3 OUTSIDE WELDS

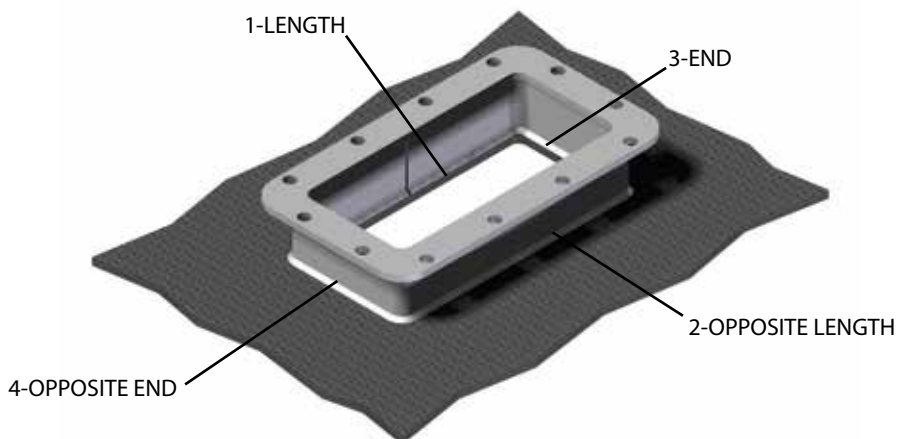



## FULL VIEW MODEL SGM-1™ INSTALLATION INSTRUCTIONS

1. Deck mounting flange is attached to the bottom of the Sight Glass by four bolts. Remove these bolts and save them. You will have (12) 1/2" - 20 x 3/4" stainless steel mounting bolts. Store the Sight Glass upside down until you are ready to reassemble it to the deck flange.

Failure to do so may result in damaged glass because the wiper flange extends below the bottom glass flange.

***NOTE: Use 1/8" diameter welding rod for the installation. Set welder to approximately 125 amps.  
For MIG use 0.045 wire at 190-195 amps.***

2. Tack weld the deck mounting flange in place as shown in steps 1 and 2 on page 10.

Do not clamp it to the deck in any way prior to tack welding. Please take all possible precautions to preserve this flatness and surface condition during the weld. Finish by welding the inside perimeter and the outside perimeter of the flange as shown in step 3 on page 10. Failure to follow this welding procedure can result in a warped flange that may not seal.

3. With the mounting bolts provided, sandwich the Teflon™ mounting flange gasket between the bottom of the Sight Glass and the top surface of the deck mounting flange. Rectorseal T Plus 2, or Teflon™ enriched sealant, should be applied to the Teflon™ mounting flange gasket to insure that there are no leaks. Install all (12) mounting bolts finger tight and proceed to tighten them in an opposite rotational pattern to a torque of 12 foot pounds.

4. The Full View Model SGM-1 Sight Glass should be mounted adjacent to the cargo control valve handwheel, with an unobstructed view of the sump and the ladder or gauge tree. NEVER mount the Sight Glass over an internal frame which blocks the view through the Sight Glass.

***If you have any questions regarding installation contact ERL at 812-948-8484.***

### WARNING

DO NOT WELD UNLESS THE BARGE IS DEVOID OF CARGO AND THE CARGO TANK HAS BEEN CLEANED AND GAS FREED. EXPLOSION HAZARD MAY EXIST.

BEFORE WELDING: SUITABLE EYE PROTECTION MUST BE WORN TO PROTECT AGAINST EYE DAMAGE DUE TO WELD FLASH. SUITABLE NON-FLAMMABLE GLOVES AND CLOTHING ARE REQUIRED.

## FULL VIEW MODEL SGM-2™



- **FULL 59 SQ. IN. OF VIEWING AREA**  
Mounted adjacent to each cargo compartment control valve, the FULL VIEW MODEL SGM-2 provides the largest and clearest view into your cargo compartment available with a full 59 square inches of viewing area, without exposing personnel to hazardous vapors.
- **EASILY REPLACED WIPER BLADES**  
Dual wipers clean the cargo side of the BOROFLOAT™ glass. The wiper blades are easily replaced in the field, and are available in a variety of materials for maximum cargo compatibility. The FULL VIEW MODEL SGM-2 is available with Teflon™, EPDM and Viton wiper blade refills.
- **3/4" THICK GROUND AND POLISHED BOROFLOAT™ GLASS**  
Each glass is fully stress relieved with ground edges and radiused corners. Four built-in drain ports in the top glass flange prevent water pooling on the glass when the full weather cover is open.
- **SOLID CONSTRUCTION AND EASY MOUNTING**  
The upper and lower glass flanges are made of 1-1/2" thick stainless steel. The weather cover is made of cast aluminum and the standard deck mounting flange is made of stainless steel for easy weld-down to your deck
- **ALLOWS EASY ACCESS TO THE CARGO SIDE OF THE VIEWING GLASS.**
- **FEATURES A LOCKING BOLT FOR SECURE LOCKING IN THE CLOSED POSITION AND POSITIVE LOCK SEAL.**
- **PARTS REFERENCE INFORMATION - SEE PAGES 9 AND 11.**



## ERL MODEL SGMRD-8™



- **FULL REGULATORY COMPLIANCE WITH 46 CFR PART 39 PARAGRAPH 39-20-3(a)**

The ERL Model SGMRD-8, 8" round marine sight glass complies with U.S. Coast Guard regulations and is suitable for use on all liquid cargo vessels.

- **ROUND 56 SQUARE INCH VIEWING AREA**

Mounted adjacent to each cargo valve control handwheel, the ERL Model SGMRD-8 gives the tankerman a 56 square inch round viewing port into the compartment without exposure to potentially hazardous vapors.

- **RADIAL GLASS WIPER**

Radial wiper cleans the bottom of the BOROFLOAT™ glass for an unobstructed view into the cargo compartment. The easily replaced wiper blades are available in Viton, Teflon, EPDM or Butyl.

- **1/2 INCH THICK GROUND AND POLISHED BOROFLOAT™ GLASS**

Each 8.5" diameter BOROFLOAT™ glass is fully stress relieved with ground edges. The top face of the glass is above the stainless steel frame to prevent water pooling when used during rain.

- **SOLID CONSTRUCTION AND EASY MOUNTING**

The ERL Model SGMRD-8 is constructed from 300 series stainless steel and mounts to any standard 8" 150 lb. class mounting flange, having (8) 0.88" diameter holes on a 11.75" diameter bolt circle.

**SGMRD-8**  
WT. = 30 lbs.

### ERL MODEL SGMRD-8™

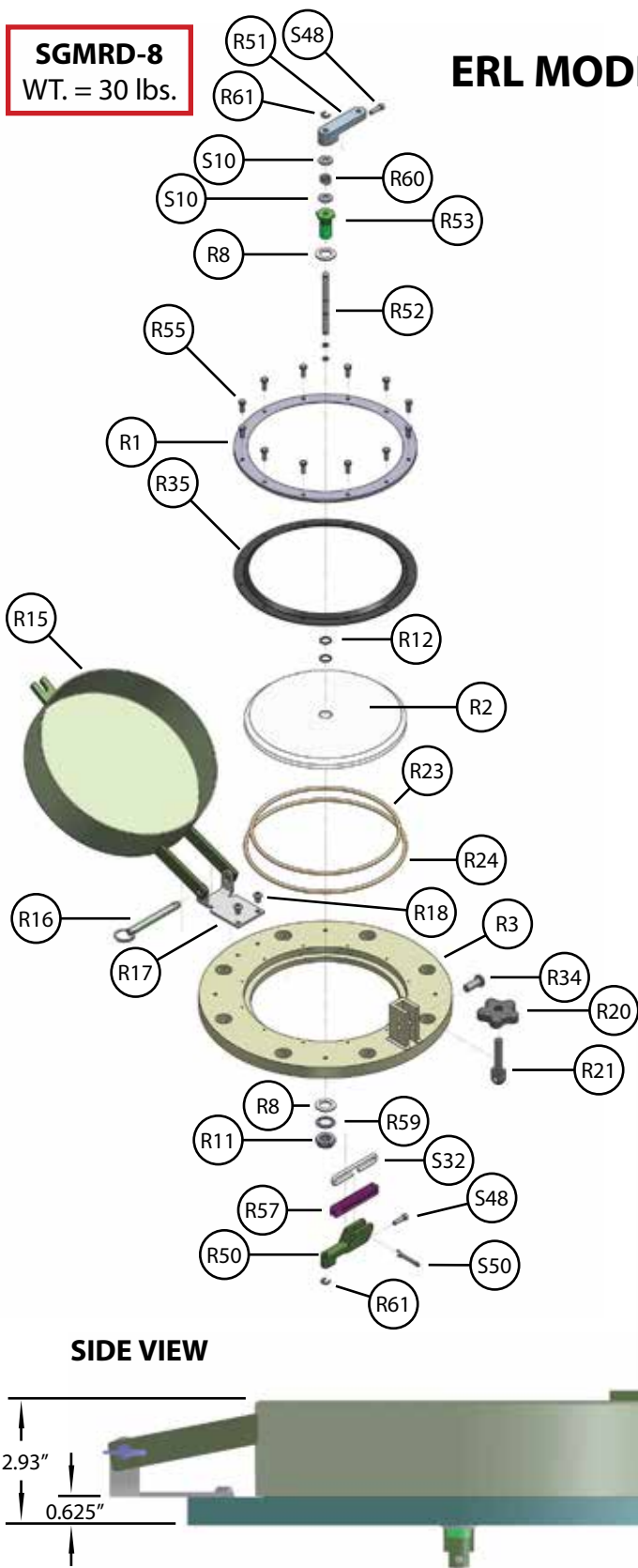

8" Round Sight Glass - Parts List		
ITEM	PART NAME	QTY
R1	Retainer Ring	1
R2	Glass	1
R3	Flange Weldment	1
R8	Washer	2
R11	Nylock Nut 5/8-18	1
R12	O-Ring	2
R15	Cover Weldment	1
R16	Hinge Pin	1
R17	Hinge Bracket	1
R18	BHCS 1/4-20 x 3/8	2
R20	Latch Knob	1
R21	Pivot Rod	1
R23	Glass O-Ring, inner	1
R24	Glass O-Ring, outer	1
R26	Flange	1
R34	BHCS 3/8-16 x 1	1
R35	Retainer Gasket	1
R50	Wiper Arm	1
R51	Wiper Handle	1
R52	Stem	1
R53	Bushing	1
R54	Stem O-Ring	2
R55	Hex Head Bolt 10-32 x 1/2	12
R57	Wiper Cartridge	1
R59	Belleville Washer	1
R60	Spring	1
R61	C-Clip	2
S10	Washer 5/16	2
S32	Teflon Wiper	1
S48	SHCS 10-32 x 3/4	2

#### DOWN VIEW

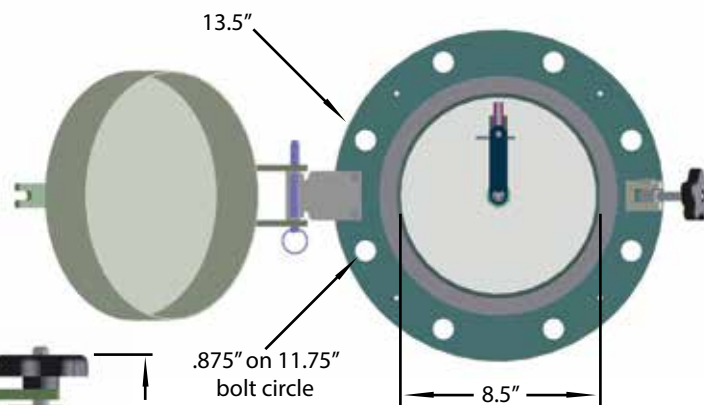

Option: Glass can be ordered without holes.





## RADIAL ARM GAUGE TREE™

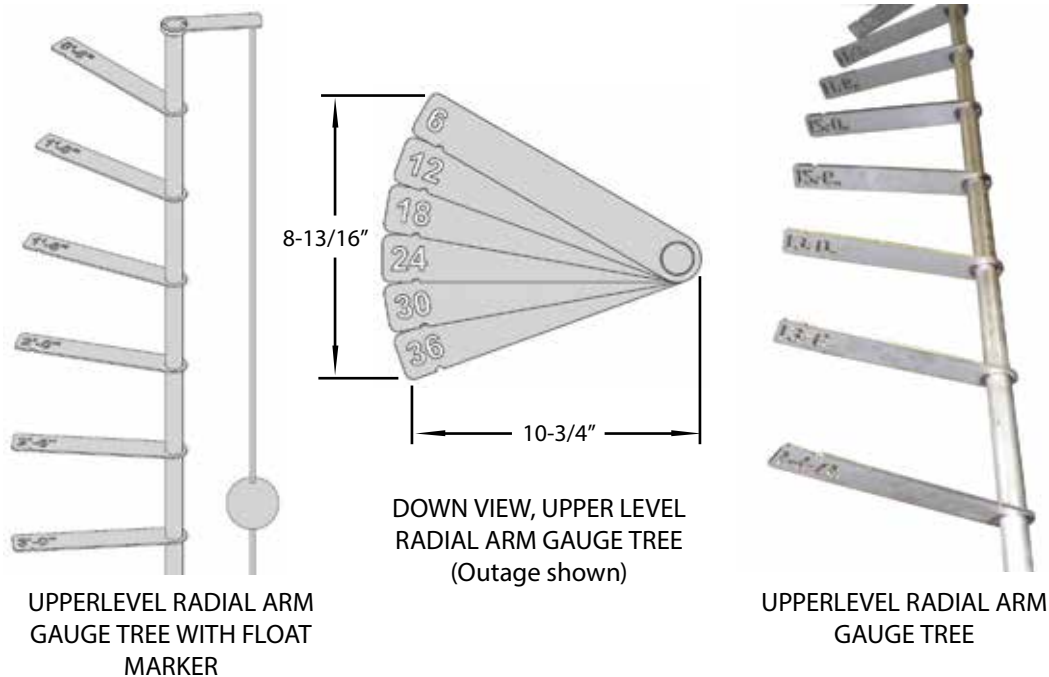

- **FULL REGULATORY COMPLIANCE**

ERL's Radial Arm Gauge Tree is USCG accepted. When used in conjunction with the Full-View SGM-1 Marine Sight Glass, the full-length Radial Arm Gauge Tree fully satisfies 46 CFR 39.20-3.2.

- **IMPROVED DEPTH PERCEPTION**

The Radial Arm Gauge Tree improves the tankerman's depth perception relative to the liquid level, helping prevent overfill spill during topping off of cargo tanks. An optional float marker is available and is recommended for white water products.

- **EASY INSTALLATION AND HEAVY-DUTY CONSTRUCTION**

Constructed from 300 series stainless steel for extended service life, the Radial Arm Gauge Tree is as easily installed during barge construction or as a retro-fit installation to an existing vessel. The shipyard can easily bracket the Gauge Tree off of the bulkhead, the ladder, or from the underside of the deck.

## RADIAL ARM GAUGE TREE™

The Radial Arm Gauge Tree is a very practical piece of equipment that aids the tankerman's depth perception when visually gauging cargo levels. Gauge Tree tabs are spaced 6" apart and can reflect either cargo innage or outage. The 36" upper level "top off" gauges, or any length you specify are available. An optional 2" Dia. marker float can be added for use in clear cargo.

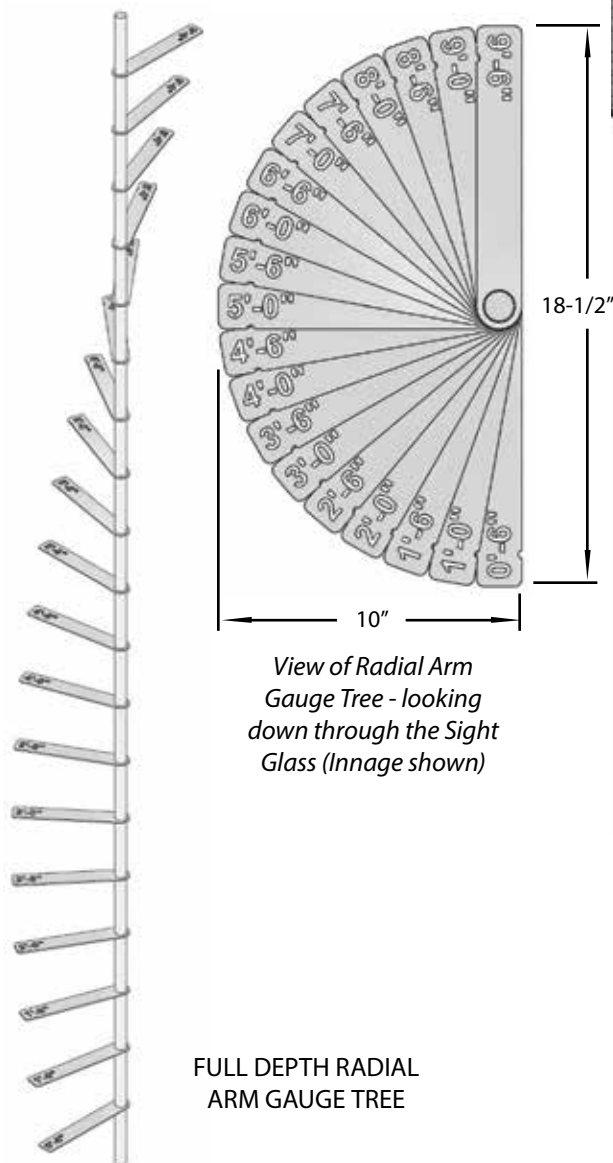
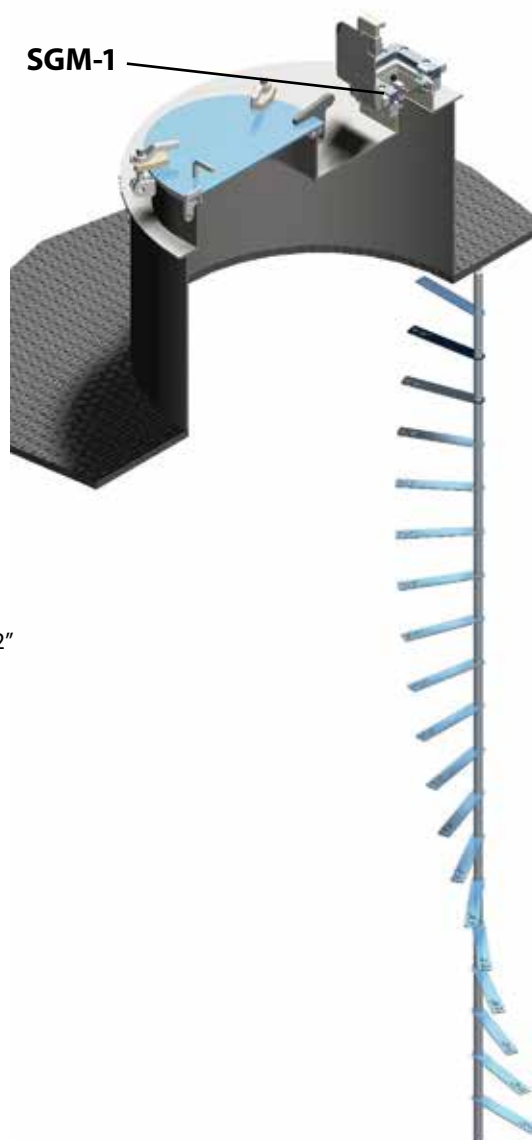

*View of Radial Arm Gauge Tree - looking down through the Sight Glass (Innage shown)*

FULL DEPTH RADIAL ARM GAUGE TREE

The Full View Model SGM-1 Marine Sight Glass provides an excellent field of view into the cargo compartment, allowing the tankerman to observe the suction/fill sump during final stripping and initial fill as well as the liquid level up the length of the Radial Arm Gauge Tree.



### RADIAL ARM GAUGE TREE™ INNAGE SHOWN

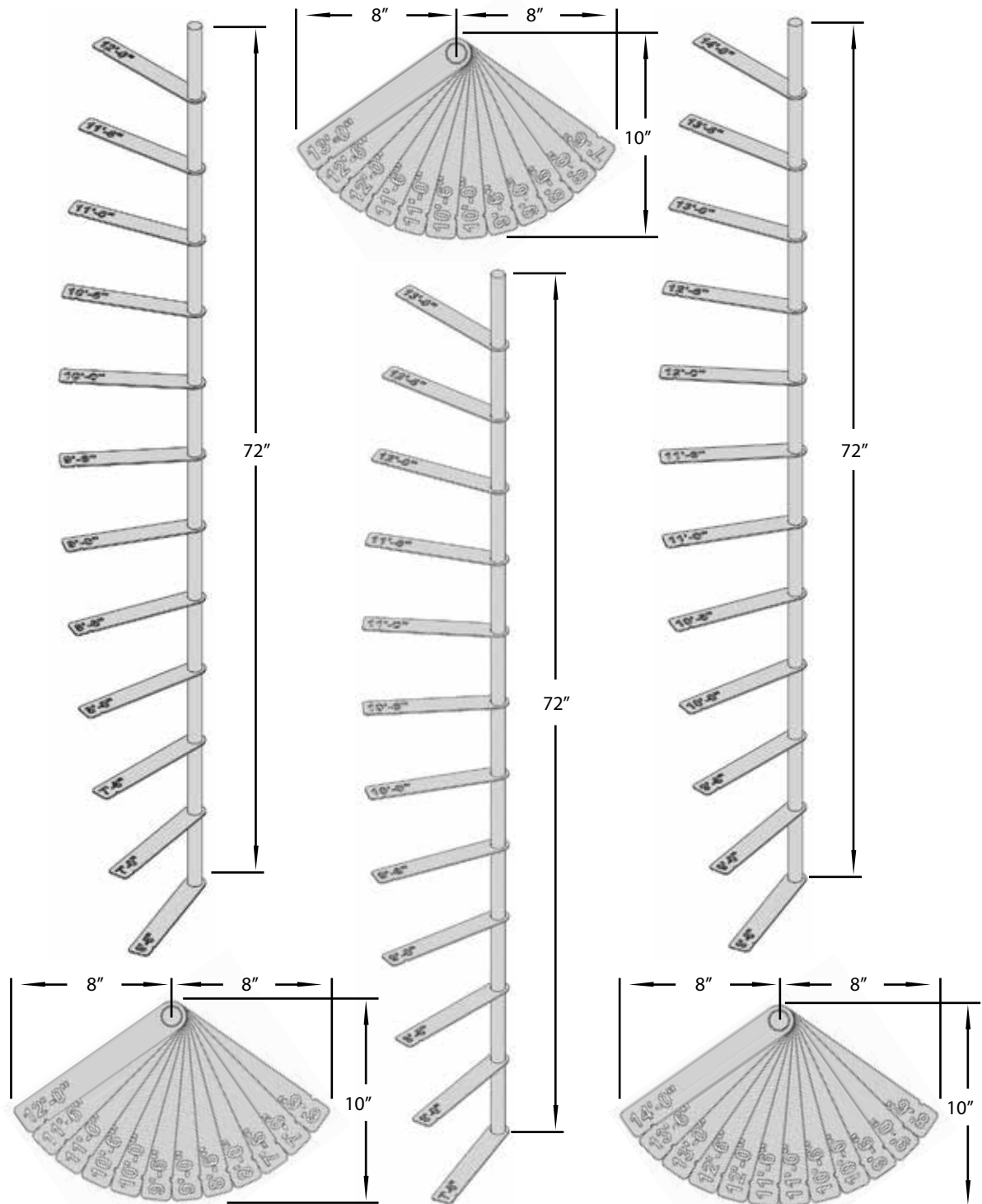

\* When ordering specify overall length and the numbers that you want on the top and the bottom tabs.

### RADIAL ARM GAUGE TREE™ OUTGAGE SHOWN

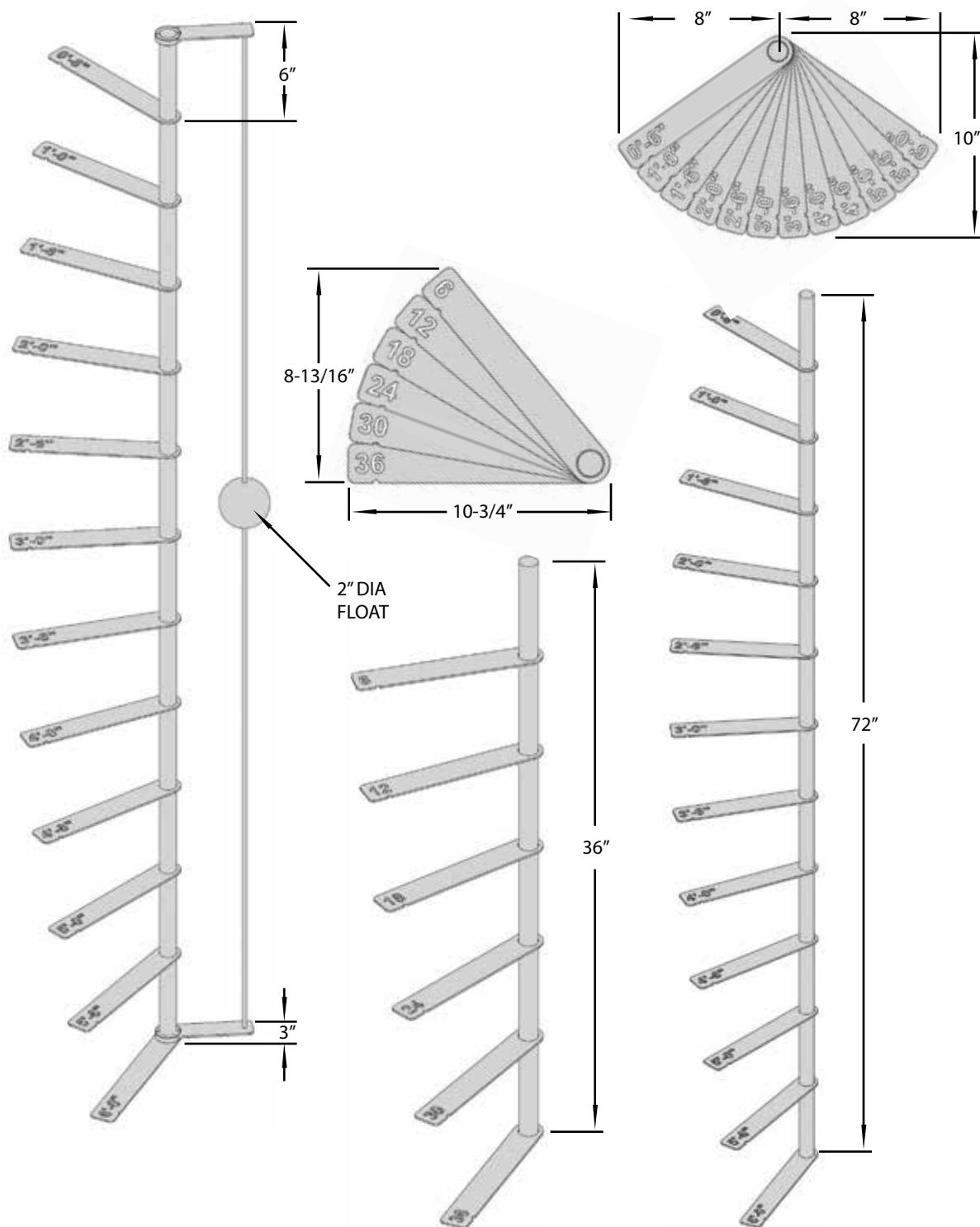

\* When ordering specify overall length and the numbers that you want on the top and the bottom tabs.



### VHSG™ VENT HEADER SIGHT GLASS

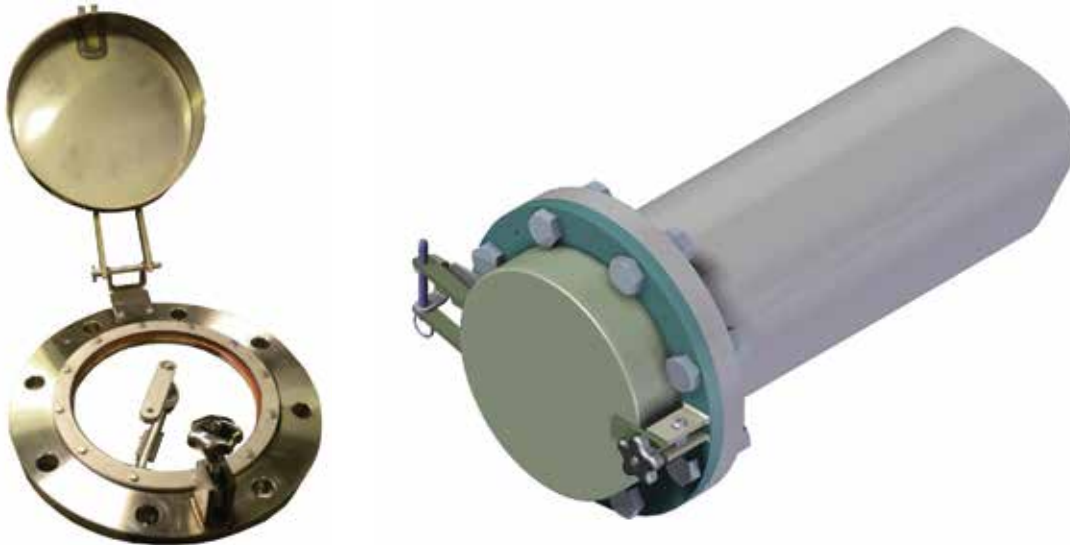

• **SUPER HEAVY DUTY CONSTRUCTION**

Our extra rugged Vent Header Sight Glass is built to provide many years of low-maintenance service. Easily mounted to any standard 150-lb. class flange, ERL also offers optional stainless steel mounting hardware and standard (or custom materials) gaskets.

• **100% STAINLESS STEEL**

Made of 300 Series Stainless Steel, ERL utilizes premium grade Teflon™ for the glass seals and 1/2" thick BOROFLOAT™ brand glass for the lense. Optional glass seal materials available upon request.

• **ALLOWS SAFE VISUAL INSPECTION**

ERL's Vent Header Sight Glass allows safe visual inspection of the inside of the vent headers without exposing personnel to hazardous vapors. If you transport polymerizing cargos, ERL's Vent Header Sight Glasses will pay for themselves in one U.S. Coast Guard inspection.

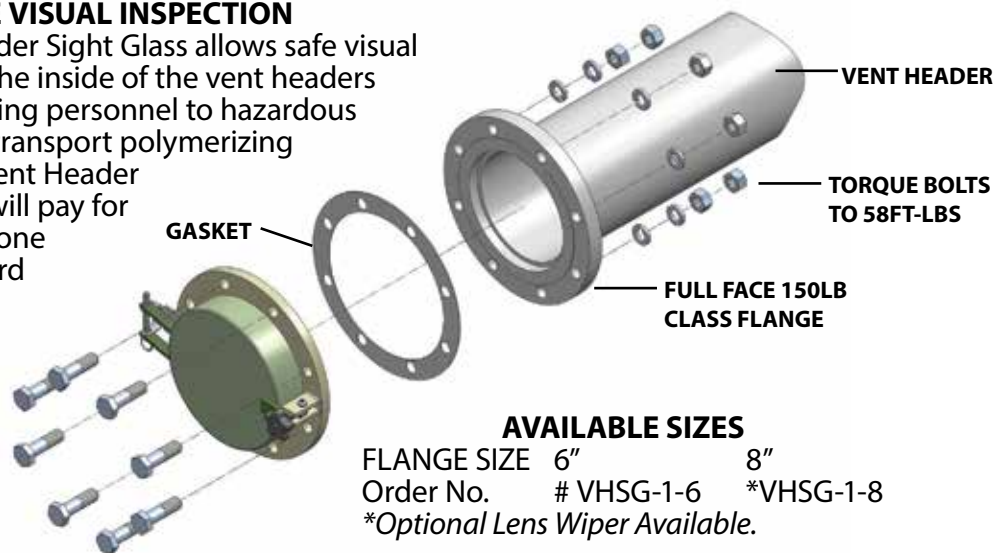

**AVAILABLE SIZES**

FLANGE SIZE 6" 8"  
Order No. # VHSG-1-6 \*VHSG-1-8  
*\*Optional Lens Wiper Available.*



Full View Model SGM-1™ Sight Glass - weather covers closed - mounted on expansion domes.





## RSA - LEVEL ALERT RISING STICK ALARM



- **FULL REGULATORY COMPLIANCE**

The Rising Stick Alarm (RSA) is U.S. Coast Guard accepted. It satisfies 46 CFR 39.20 3(b), 39.20-(b), as well as OPA 90 regulations for overfill devices and is suitable for use on ABS classed vessels. The RSA utilizes the ERL L-40 alarm Reed switch which carries a UL approval for use in hazardous cargo locations.

- **TWO IN ONE**

The RSA combines both a Rising Stick Gauge and a Level Alert Alarm into one unit. This reduces the number of tank openings while meeting the required CFR's (shown above).

- **EASY INSTALLATION**

Simply bolt the RSA to an 8" Class 150 flanged pipe stand located at or near the geometric center of the cargo compartment. The deck opening must be large enough for the 7" dia. float to pass through.

- **HEAVY DUTY CONSTRUCTION**

All welded components are 300 series stainless steel. Powerful NEODYMIUM #38 rod magnets are used to insure superior coupling strength between the CERAMIN #8 float magnet and the tri-colored gauge rod. The tri-colored gauge rod, color coded to industry standards, is hermetically sealed by design, to provide extended service life.

- **SIMPLE, RELIABLE OPERATION**

Stainless steel linear slide floats actuate the liquid level switches. The high level switch actuates (opens) when the cargo compartment is 95% full. Subsequently the overfill switch actuates (opens) when the cargo compartment is 98% full. With the Rising Stick Alarm connected to the loading dock's alarm/shutdown system and/or to barge mounted alarm annunciator panel, the risk of overfill spills are significantly reduced.

## MODEL DS-39 RISING STICK GAUGE™ FOR TANK TOP LIQUID LEVEL INDICATION



- FULL REGULATORY COMPLIANCE**  
 The Model DS-39 is U.S. Coast Guard accepted. It satisfies 46 CFR 39.20 3(b) as well as OPA 90 regulations for overfill devices and is suitable for use on ABS classed vessels.
- SAFETY**  
 Personnel are not exposed to hazardous cargo vapors on the tank top when using the reliable Model DS-39 Liquid Level Gauge. The hazard of overfill spills is greatly reduced when properly using the DS-39.
- EASY INSTALLATION**  
 Simply bolt the DS-39 to an 8" flanged pipe stand located at or near the geometric center of the cargo compartment. The deck opening must be large enough for the 7" dia. float to pass through. ERL can provide optional prefabricated mounting standpipes, flange gaskets and mounting hardware upon request.
- HEAVY DUTY CONSTRUCTION**  
 All welded components are 300 series stainless steel. Powerful NEODYMIUM #38 rod magnets are used to insure superior coupling strength between the CERAMIN #8 float magnet and the tri-colored gauge rod. The tri-colored gauge rod, color coded to industry standards, is hermetically sealed by design, to provide extended service life.

### Excerpted from Federal Register, 21 Oct "94" 33CFR Part 155 Minimum Standards For Overfill Devices; Barges

The Coast Guard will allow the owners and operators of tank barges to select one of three alternatives: (1) an overfill alarm on each tank which includes circuitry to sufficiently identify which individual tanks' overfill system is alarming, (2) an automatic shutdown system for the entire barge and transfer facility, or (3) a high level indicating device installed on each tank, such as a stick gauge.

### DESCRIPTION

ERL's magnetically coupled rising stick gauge is designed to provide continuous visual liquid level indication on the cargo tank top. The length of indication is specified when ordering and can include full compartment depth configurations. One meter of indication reflecting the liquid level in the upper one meter of the cargo compartment is typical and fulfills the minimum requirements set forth in 46 CFR 39.20-3(b) as well as OPA 90 requirements for overfill devices. The tricolored gauge rod with a powerful magnet at its base is positioned inside a stainless steel pipe extending down from the tank top. A 7" diameter float with powerful magnets inside floats up and down the sealed pipe with changes in the liquid level. Due to the powerful magnetic coupling between the float and the internal gauge rod, they move together providing a continuous visual indication of liquid level on the tank top.

When not in use, and with the tri-colored gauge rod lowered within the stainless steel tube, a protective weather cap, with tether, is screwed in place. The operation is fully automatic, but the user must remove the weather cap prior to each use and replace the cap after each use.





### MODEL DS-39 RISING STICK GAUGE™ OPERATING INSTRUCTIONS

**Step 1**  
REMOVE WEATHER CAP

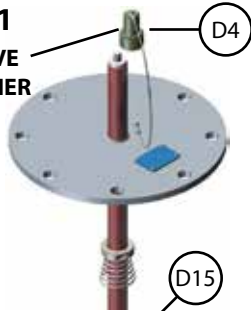

**Step 2**  
VERIFY ROD CAN MOVE

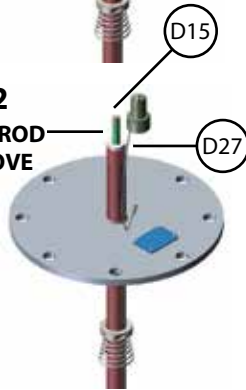

**Step 3**

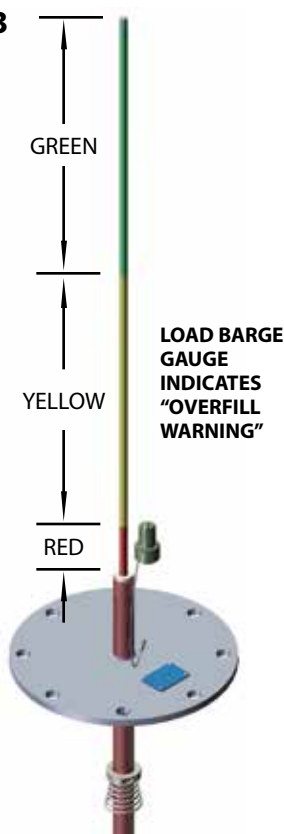

Periodically water should be removed from the main tube. In subfreezing temperature, antifreeze should be added to the main tube to prevent freeze up.

Avoid dropping the gauge into the tube after use.

ERL Model DS-39 Rising Stick Gauge

**Step 4**  
GRASP AND MANUALLY LOWER

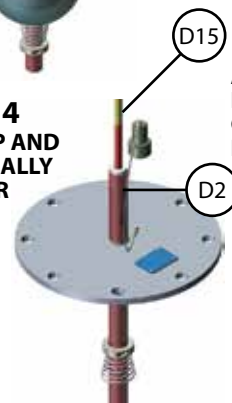

AVOID DROPPING GAUGE ROD INTO TUBE

**Step 5**  
REPLACE WEATHER CAP

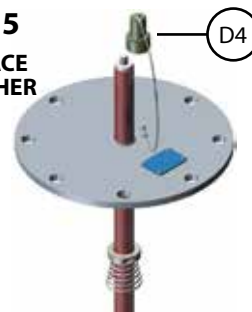

### MODEL DS-39 RISING STICK GAUGE™ ORDER CHECKLIST

REFER TO FIGURES 1 & 2 TO ANSWER THE FOLLOWING QUESTIONS

- 1) Tank Depth: \_\_\_\_\_ feet \_\_\_\_\_ inches
- 2) Flanged standpipe height \_\_\_\_\_ inches
- 3) Deck Thickness \_\_\_\_\_ inches
- 4) Distance from underside of deck to highest level indicated \_\_\_\_\_ inches.
- 5) Verify "A" dimension: 2 \_\_\_\_\_ + 3 \_\_\_\_\_ + 4 \_\_\_\_\_ = "A" Dimension \_\_\_\_\_ (7" min.)
- 6) Specify overall length of unit: Inches of indication \_\_\_\_\_ + "A" Dim. \_\_\_\_\_ + 8" + 6" O.A.L. \_\_\_\_\_

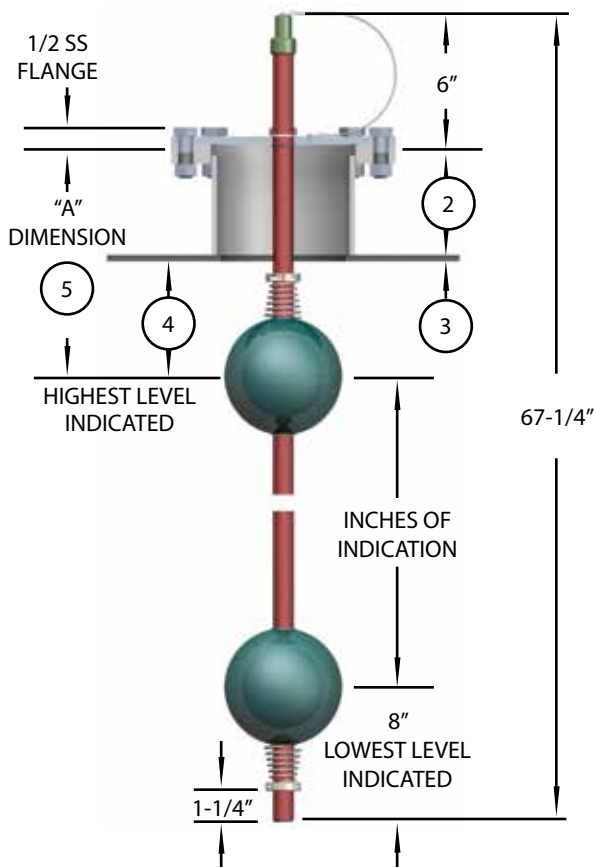

**FIGURE 1**  
**NOTES:**

- 1) The flanged standpipe, gasket and s.s. mounting hardware are available as options.
- 2) Installation at or near the geometric center of the cargo compartment is by customer.
- 3) "A" Dimension is 14 inches if not specified otherwise.

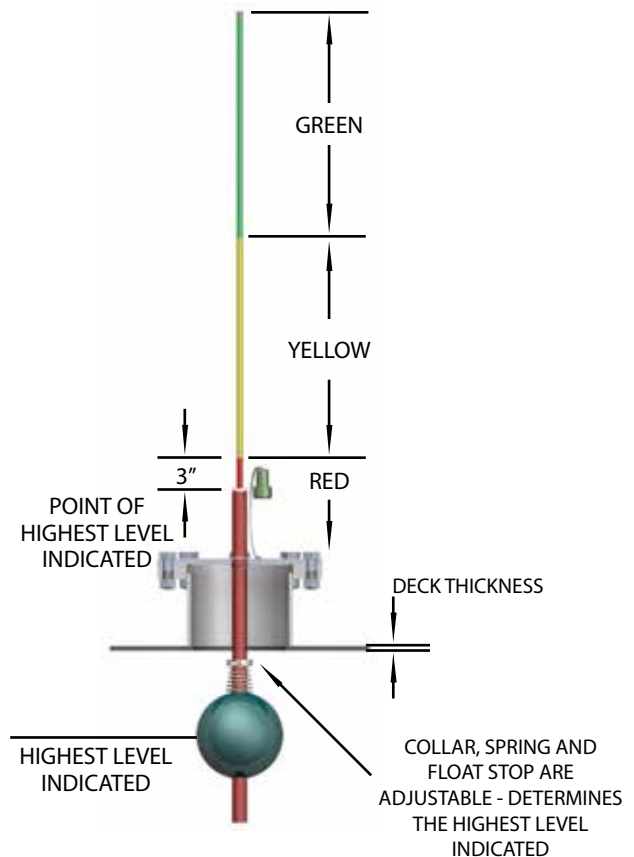

**FIGURE 2**  
**NOTES:**

- 1) Dipstick shown at the highest level of indication.



### MODEL DS-39 RISING STICK GAUGE™ STANDARD DIMENSIONS

ERL can make your DS-39 Rising Stick Gauge to your specifications. One meter of indication meets the minimum overfill requirements.

The 7.0" diameter float is 50% submerged in liquid having a specific gravity of 1.0 S.G.

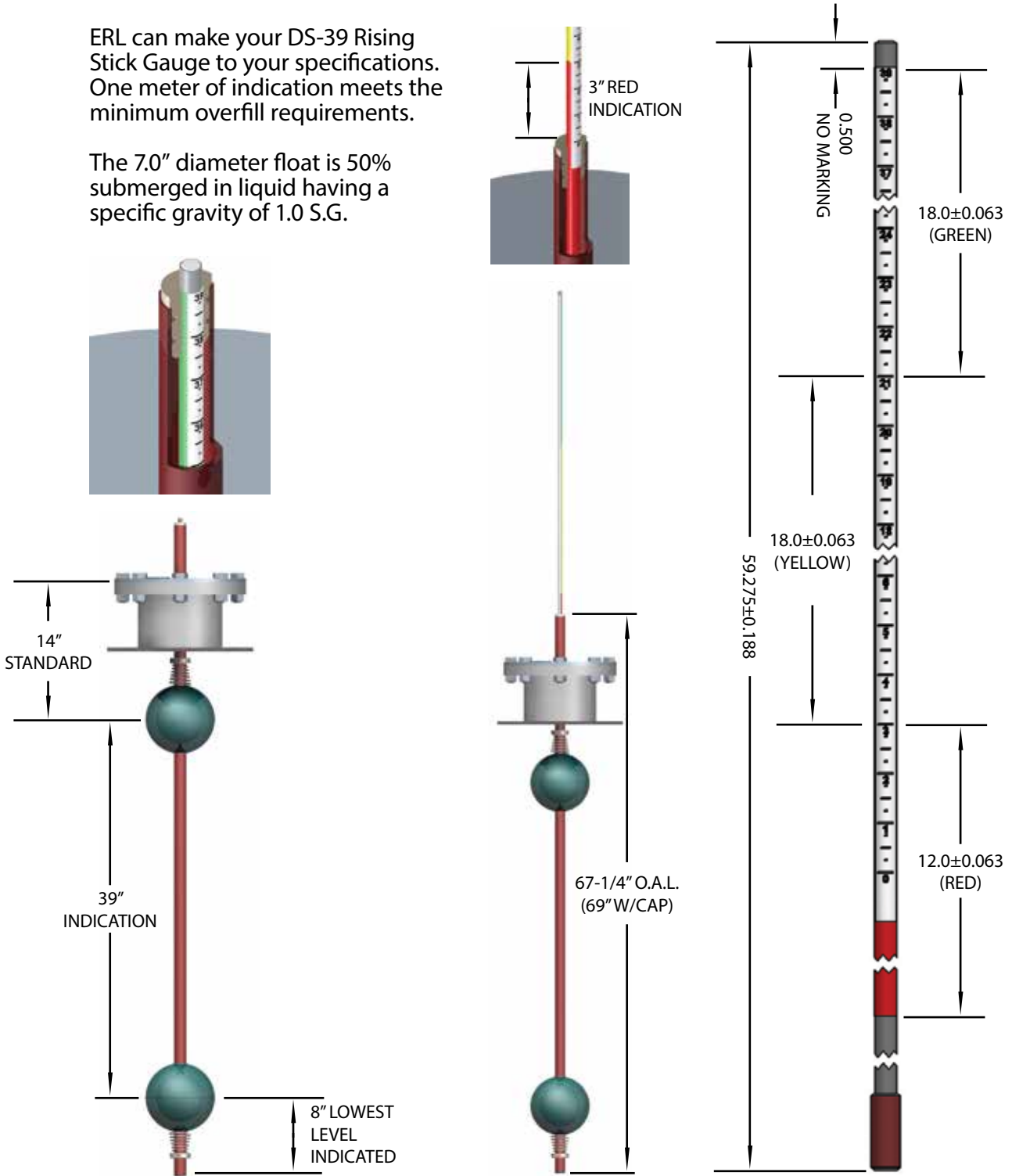

### MODEL DS-39 RISING STICK GAUGE™

#### REPLACEMENT TRI-COLORED GAUGE STICKS

ERL's Tri-colored gauge sticks are designed and manufactured to provide extended service life. If the Gauge Stick becomes damaged, replacements are readily available. Simply provide the Serial No. of the old stick, which is located near the magnet housing at the base of the stick, or provide the Serial No. of the unit from the data tag on the unit flange.

Confirmation of the dimensions listed below and identified by the adjacent drawing are required if the replacement stick is being ordered for use in a non-ERL manufactured unit.

- A. \_\_\_\_\_ Overall length
- B. \_\_\_\_\_ Green Length
- C. \_\_\_\_\_ Yellow Length
- D. \_\_\_\_\_ Red Length
- E. \_\_\_\_\_ Top Gauge Marking Number
- F. \_\_\_\_\_ Diameter of magnet housing
- G. \_\_\_\_\_ Diameter of gauge rod
- H. \_\_\_\_\_ Guide Bushing diameter  
(if non-ERL unit)

ERL's DS-39 uses a standard Teflon guide bushing. When ordering and using ERL Tri-colored gauge sticks for use in non-ERL manufactured gauges be sure to include all the information requested. This information will be important if it is necessary for us to provide a new Teflon guide bushing sized to fit your unit.

Standard ERL Tri-colored gauge sticks perform well to 280°F. Prolonged use in temperatures higher than 280°F can cause the green, yellow and red colors to fade. For high temperature service specify our H.T. Series, high temperature gauge rods good for continuous service to 365°F.

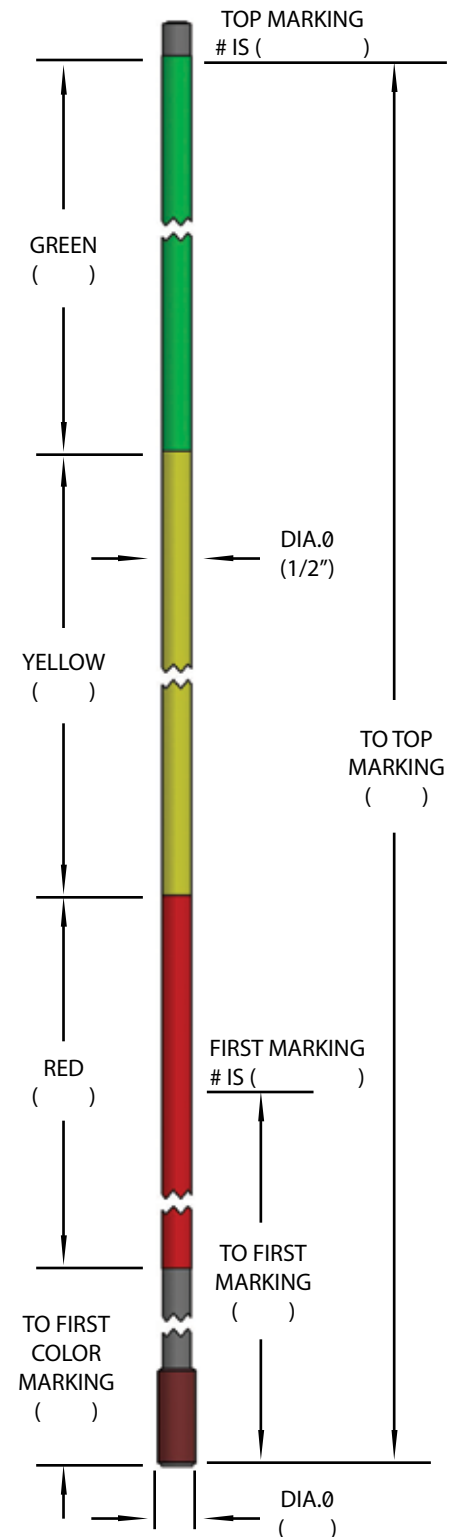



**MODEL DS-39 RISING STICK GAUGE™**

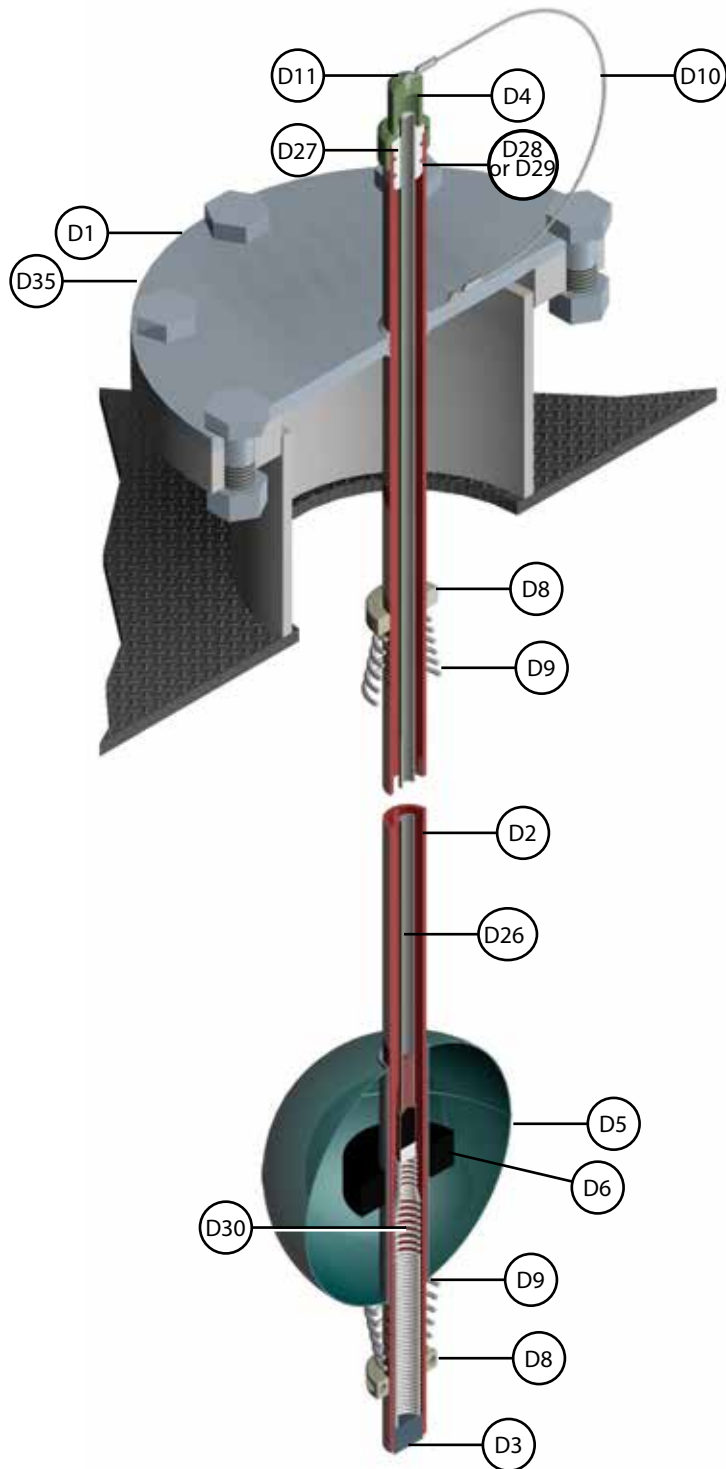

**Parts List ~ DS-39  
Rising Stick Gauge**

ITEM	PART NAME	QTY
D1	Flange	1
D2	External Main Tube	1
D3	Main Tube Plug	1
D4	Main Tube Top Cap	1
D5	Float	1
D6	Float Magnet	2
D8	Shaft Collar	2
D9	Float Spring	2
D10	3D10 Lanyard	1
D11	Drive Screw	2
D12	I.D. Tag	1
D13	Drive Screw	4
D15	Internal Stick	1
D16	Internal Magnet Holder	1
D17	Internal Magnet	1
D18	Reflective Sheeting, Green	1
D19	Reflective Sheeting, Yellow	1
D26	Internal Stick Assembly	1
D27	Top Tube Bushing	1
D28	O-Ring, Viton	2
D29	O-Ring, EPDM	2
D30	Bumper Spring	1
D33	Flat Washer	1
D35	Weldment 2	1
D38	Weldment 1	2
D4HT	Main Tube Top Cap (High Temp)	1
D16HT	Internal Magnet Holder (High Temp)	1
D17HT	Internal Magnet (High Temp)	1

### MODEL DS-39 SPECIAL RISING STICK GAUGE™

Dual sticks can show full tank depth.

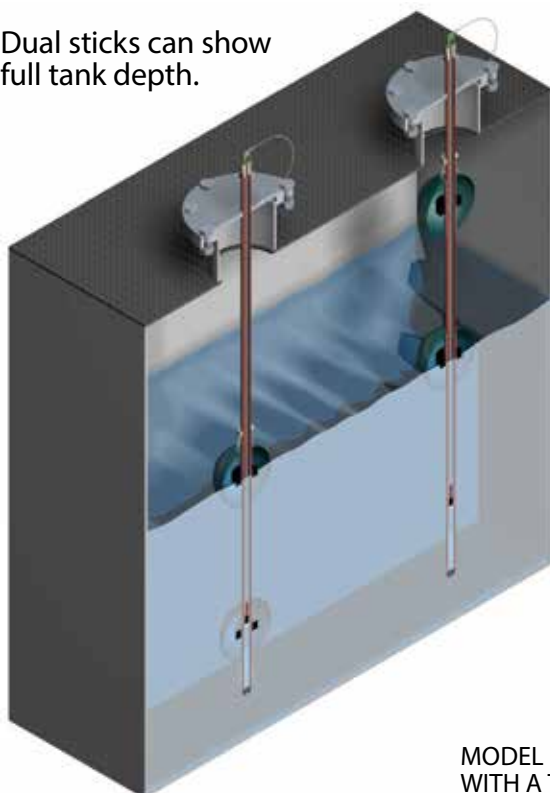

Threaded mounting bushings, special flanges and hatch cover mounting arrangements are available.

MODEL DS-39 WITH A THREADED BUSHING

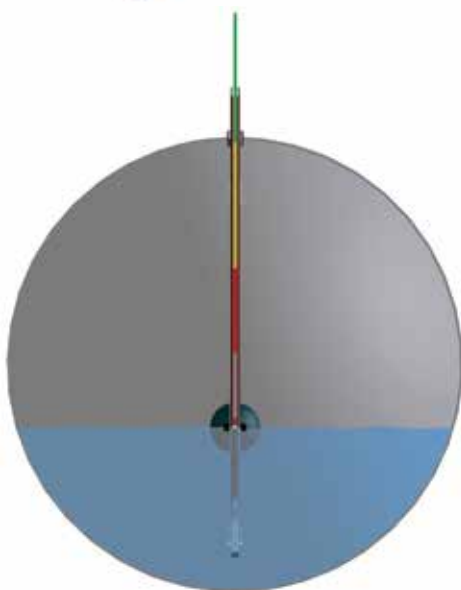

MODEL DS-39 CAN BE USED ON SLOP TANKS OR FUEL TANKS



MODEL DS-39 THREADED BUSHING WITH STICK SHOWING

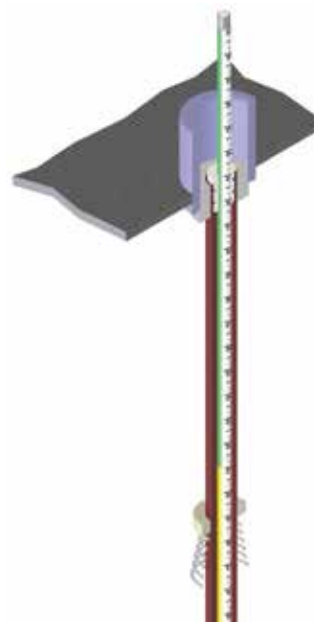

MODEL DS-39 USED ON TOWBOAT FUEL TANK

## HIGH LEVEL/OVERFILL TABS

- 100% STAINLESS STEEL**  
ERL offers High Level/Overfill Tabs that are manufactured out of 300 series stainless steel which ensures a quality product with extend life during field operations.
- OPERATIONS & MANUFACTURING**  
ERL's High Level/Overfill Tabs are easily attached to the Radial Arm Gauge Tree by a stainless steel split collar welded to the support arm. The High Level/Overfill Tabs are precision laser cut and are welded to  $\frac{3}{4}$ " nuts that are easily adjusted to desired height along a  $\frac{3}{4}$ -10 stainless steel all-thread.



## DRAFT MARKS

- OPERATIONS & MANUFACTURING**  
ERL offers precision cut carbon steel Draft Marks to assist with draft readings on the side of your barge. Draft Marks are constructed out of .312" Carbon Steel plate (.25" stainless steel as an option) and are precision laser cut to ensure a consistent size. Draft Marks are standard 6" in height however ERL can customize a size according to customers preferences.

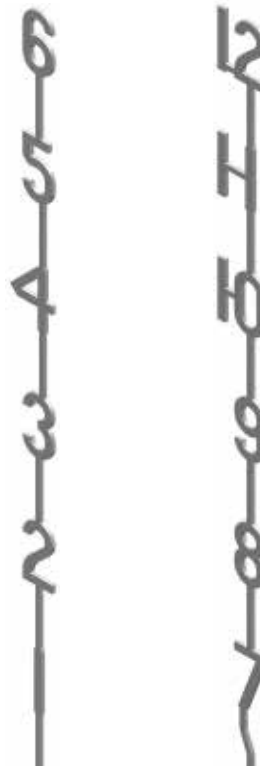

### SAMPLER BALL VALVES



### PORTABLE GAUGING SYSTEMS







## VAPOR CONTROL VALVES

The B-type vapor control valve is available in four models. The original B-type, micro "B" and MMC (Asia) F50 are 2-inch (50) full-bore ball valves. The Mini Micro "B" is a 1 1/2-inch (38) which is extremely cost-effective. All valves are flanged for ease in installation and very accurate positioning. The materials of construction are 316SS with bronze cap. The ball valves have Teflon seals. 1/2 liter sampling in both sizes is available by using MMC sampling tapes. All gauging tapes fit directly into the valve.

### SPECIFICATIONS

#### MATERIAL:

316 Stainless steel with bronze cap\* Ball valve seals - Teflon™. All other seals Viton as standard.

\*Stainless steel cap available.

#### MOUNTING FLANGE DIMENSIONS:

- 1.) 2" "B" Valve (2318-2S-F316-BC) - 6" (152) O.D., BC 4 3/4" (121)  
2" Micro "B" Valve (2318-2S-FMS-BC) - Bolt holes 4 3/4" (19)
- 2.) 1-1/2" Mini Micro "B" (2318-2S-F316BC) - 5" (127) O.D., BC 3 7/8" (98)  
- Bolt holes 4 5/8" (16)
- 3.) F50 50mm (2") MMC-A Valve -155mm (6.1") O.D., BC 120mm (4.72")  
- Bolt holes (4) 19 (0.75")

#### ESTIMATED WEIGHTS:

- 1.) 2" "B" Valve (2318-2S-F316-BC) ..... 14 lb. (6.35 kg)
- 2.) 2" Micro "B" Valve (2318-2S-FMS-BC) ..... 13 lb. (5.9 kg)
- 3.) 1-1/2" Mini Micro "B" (2318-2S-F316BC) ..... 9 lb. (4.1 kg)
- 4.) F50 50mm 2" MMC-A Valve ..... 9 kg (19.8 lbs.)

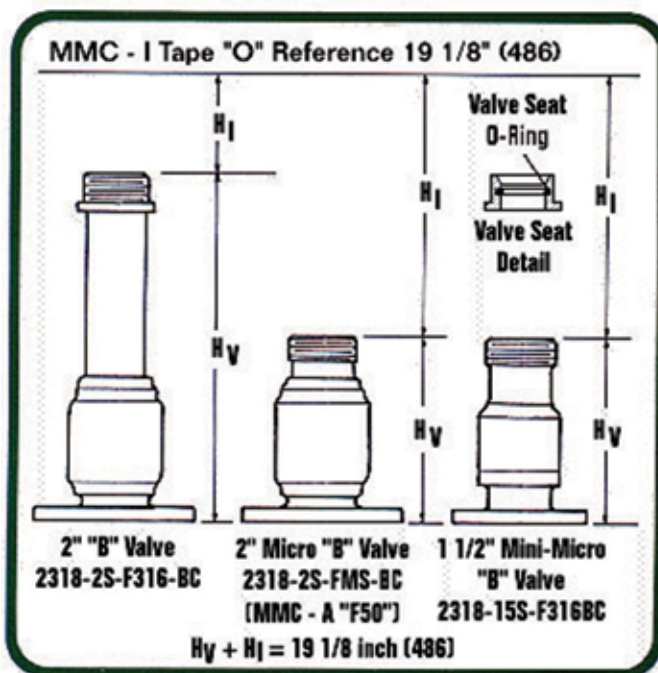

Model	HV	HI	HV & HI
2318-2S-F316BC 2" "B" Valve	13 1/8	6	19 1/8
2" Flange-6" O.D. (4 3/4 BC-[4] 3/4" Holes)	(333)	(152)	(486)
2318-2S-FMS-BC BC-2" Micro "B"	7	12 1/8	19 1/8
2" Flange-6" O.D. (4 3/4 BC-[4] 3/4" Holes)	(178)	(308)	(486)
F50 2" MMC-A Valve JIS 10K	(178)	(322)	(500)
50 Flange-155 O.D. (120) BC-4 Holes (19)	7	12 1/8	19 1/8
2318-1.5S-F316BC 1 1/2" Mini Micro "B"	7	12 1/8	19 1/8
1 1/2" Flange-5" O.D. (3 7/8 BC-[4] 5/8" Holes)	(178)	(308)	(486)

### VAPOR CONTROL VALVES

#### FEATURE NOTES:

- 1) Gauging tape and sensor anti-static coated.
- 2) Positive internal tape stop on rewind.
- 3) Tape is color marked to insure full rewind position. Tape direction and motion easily seen.
- 4) Sight glass easily removable for cleaning or replacement. Tempered glass used.
- 5) Internal reel stop to prevent backward tape rewind.
- 6) Coiled expansion type grounding cable with large alligator clip. Standard Supply
- 7) Interchangeable barrels are available for all MMC Vapor Valves. A, B, MB, MMB, S, and K series. Mating barrels for competitive valves are also available.
- 8) Molded storage case is standard supply. Includes instruction manual and spare battery.



Closed Tape is shown connected to MMC Micro "B" valve.

### FLEXI-DIP GAS-TIGHT TRIPLE-FUNCTION PORTABLE GAUGING TAPE

The Closed Flexi-Dip™ (measuring tape) is battery-operated and intrinsically safe. When installed in a vapor control valve mounted on a storage (cargo) tank, it forms a tightly sealed system that prevents toxic vapors from escaping and constitutes a closed gauging system for that tank. The tape is marked in Metric or English units and is anti-static coated (as is the sensor). The tape is appropriately marked to show tape direction and motion easily, and to ensure the full rewind position. A coiled grounding cable with large alligator clip is supplied as standard. This closed system is recognized by many worldwide regulatory bodies as equivalent to a fixed gauging system if the tape remains in the valve for the duration of the cargo handling operation.

#### SPECIFICATIONS

##### ACCURACY OF TAPE READING:

fluid level= +/- 1/8 inch (3mm)

##### BATTERY:

9 volt Eveready #522 or Mallory MN1604

##### AMBIENT TEMPERATURE LIMITS:

-20°F (-7°C) to 120°F (49°C)

##### PRODUCT TEMPERATURE LIMITS:

-40°F (-40°C) to 180°F (82°C)

##### TAPE LENGTHS:

50 ft. (15m), 75 ft. (25m), 100 ft. (30m)

##### TYPICAL WEIGHTS:

14 lbs. (6.4KG)

##### PRESSURE LIMITS:

3 psi working, 7.5 psi maximum

##### APPROVALS:

Intrinsically safe, FM, BASEEFA, CSA, SAA

**SECTION  
02**

# OVERFILL PROTECTION PRODUCTS

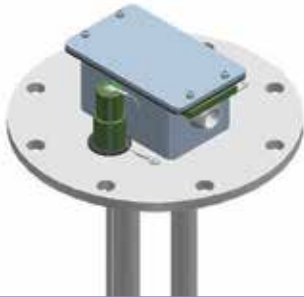

**Level Alert™ II High Level/  
Overfill Alarm Sensor** pg 45

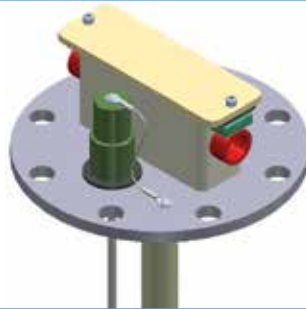

**Level Alert III High Level/  
Overfill Alarm Sensors** pg 49



**RSA - Rising Stick Alarm** pg 50



**High Level/Overfill  
System Acc.** pg 51



**APM-1B Lite Portable  
Alarm Panel** pg 57



**APM 1TLB Tandem  
Portable Alarm Panel** pg 59



**APM-2™ Fixed Alarm  
Panel** pg 60



**APM-2F™ Fixed Alarm  
Panel** pg 66



**APM-2F-APA Anti  
Pollution Alarm** pg 68



**APM-2E Efficient Fixed  
Alarm Panel** pg 71



**APM-3** pg 72



**SUPERAC™ Model III 12"  
Round Marine Safety  
Relief Valve (Spill Valve)** pg 73



APM-2™ High Level/Overfill Alarm Annunciator Panel for a three compartment barge.



LEVEL ALERT II High Level/Overfill Liquid Level Alarm Sensor Installed.



BTS-1 Barge-to-Shore Connector with BCS-001 located on outside of Hubbell weather tight box.



LEVEL ALERT MODEL II™ High Level/Overfill Liquid Level Alarm Sensor.



LEVEL ALERT MODEL II™ High Level/Overfill Liquid Level Alarm Sensor, Sampler Ball Valve and DS-39™ One Meter Rising Stick Gauge.



DS-39™ One Meter Rising Stick Gauge, Sampler Ball Valve, 2.5" Equate PV Valve, and SGM-1 Full View Sight Glass.



## EXCERPTS FROM FEDERAL REGISTER

PART 11 - Dept. of Transportation - Coast Guard - June 21,1990

46CFR Part 39 Vapor Control Systems  
Subpart 39.20 Design and Equipment  
§ 39.20-7 Tankship liquid overfill protection -T/ALL

**The following section, reprinted here for your convenience, contains the USCG rules and regulations regarding overfill protection.**

### 39.20-7 Tankship liquid overfill protection-T/ALL

(a) Each cargo tank of a tankship must be equipped with an intrinsically safe high level alarm and a tank overfill alarm.

(b) The high level alarm and tank overfill alarm required by paragraph (a) of this section, if installed after July 23, 1990 must:

- (1) Be independent of each other;
- (2) Alarm in the event of loss of power to the alarm system or failure of electrical circuitry to the tank level sensor; and
- (3) Be able to be checked at the tank for proper operation prior to each transfer or contain an electronic self- testing feature which monitors the condition of the alarm circuitry and sensor.

(c) The high level alarm required by paragraph (a) of this section must:

- (1) Alarm before the tank overfill alarm, but no lower than 95 percent of tank capacity;
- (2) Be identified with the legend "High Level Alarm" in black letters at least 50 millimeters (2 inches) high on a white background; and
- (3) Have audible and visible alarm indications that can be seen and heard on the vessel where cargo transfer is controlled.

(d) The tank overfill alarm required by paragraph (a) of this section must:

- (1) Be independent of the cargo gauging system;
- (2) Have audible and visible alarm indications that can be seen and heard on the vessel where cargo transfer is controlled and in the cargo deck area;



## EXCERPTS FROM FEDERAL REGISTER

PART 11 - Dept. of Transportation - Coast Guard - June 21,1990

46CFR Part 39 Vapor Control Systems  
Subpart 39.20 Design and Equipment  
§ 39.20-7 Tankship liquid overfill protection -T/ALL (*continued*)

### OVERFILL PROTECTION (*continued*)

- (3) Be identified with the legend "TANK OVERFILL ALARM" in black letters at least 50 millimeters (2 inches) high on a white background; and
- (4) Alarm early enough to allow the person in charge of transfer operations to stop the transfer operation before the cargo tank overflows.
- (e) If a spill valve is installed on a cargo tank fitted with a vapor collection system, it must meet the requirements of Sec. 39.20-9(c) of this part.
- (f) If a rupture disk is installed on a cargo tank fitted with a vapor collection system, it must meet the requirements of Sec. 39.20-9 (d) of this part. 39.20-9 Tank barge liquid overfill protection-B/ALL.

Each cargo tank of a tank barge must have one the following liquid overfill protection arrangements.

- (a) A system meeting the requirements of 39.20-7 of this part which:
  - (1) Includes a self-contained power supply; "The APM-2 Annunciator Panel connected to ERL Liquid Level Sensors satisfy this requirement."
  - (2) Is powered by generators installed on the barge; or
  - (3) Receives power from a facility and is fitted with a shore tie cable and a 120 volt 20 amp explosion proof plug which meets:
    - (i) ANSI/NEMA WD6;
    - (ii) NFPA 70, Articles 410-57 and 501-12; and
    - (iii) 111.105-9 of this chapter.
- (b) An intrinsically safe overfill control system which: "ERL Liquid Level Sensors satisfy this requirement."
  - (1) Is independent of the cargo gauging device required, by 39.20-3(a) of this part;
  - (2) Actuates an alarm and automatic shutdown system at the facility overfill control panel, or on the vessel to be lightered if a lightering operation, 60 seconds before the tank becomes 100 % liquid full;



## EXCERPTS FROM FEDERAL REGISTER

PART 11 - Dept. of Transportation - Coast Guard - June 21,1990

46CFR Part 39 Vapor Control Systems  
Subpart 39.20 Design and Equipment  
§ 39.20-7 Tankship liquid overfill protection -T/ALL (*continued*)

### OVERFILL PROTECTION (*continued*)

- (3) Is able to be checked at the tank for proper operation prior to each loading;
  - (4) Consists of components which, individually or in series, will not generate or store a total of more than 1.2 V, 0.1 A, 25 mW, or 20 microjoules;
  - (5) Has at least one tank overfill sensor switch with normally closed contacts per cargo tank;
  - (6) Has all tank overfill sensor switches connected in series;
  - (7) Has interconnecting cabling that meets 111.105-15(b) of this chapter; and
  - (8) Has a male plug with a 5 wire, 16 amp connector body meeting IEC 309-1/309-2 which is:
    - (i) Configured with pins S2(L2) and RI(LI) for the tank overfill sensor circuit, pin G connected to the cabling shield, and pins N and T3(L3) reserved for an optional high level alarm circuit meeting the requirements of this paragraph; and
    - (ii) Labeled "Connector for Barge Overflow Control System" and with the total inductance and capacitance of the connected switches and cabling. "API Recommended Practice 1125 also applies to the wiring of Liquid Level Sensors."
- (c) A spill valve which:
- (1) Meets ASTM F1271;
  - (2) Relieves at a pressure higher than the pressure at which the pressure relief valves meeting the requirements of 39.20-11 operate;
  - (3) Limits the maximum pressure at the cargo tank top during liquid overfill, at the maximum loading rate for the tank, to not more than the maximum design working pressure for the tank; and
  - (4) If the vessel is in ocean or coastwise service, has provisions to prevent opening due to cargo sloshing.
- (d) A rupture disk arrangement which meets paragraphs (c) (2), (c) (3) and (c) (4) of this section and is approved by the Commandant (G-MSO).





## API RECOMMENDED PRACTICE 1125

2.2.2 Tank barge level sensor circuits (or sensor relay circuits, for systems which also meet the requirements of 46 CFR 39.20-7) should have normally closed contacts and be grounded by connecting the barge cable shield to the ground pin of the connector.

2.2.3 The total connected inductance and capacitance of switches and cabling aboard the barge should not exceed 0.6 mH (inductance) or 0.18 gF (capacitance) at 20.66 volts DC/155 mA. The length of connected cable on the barge should not exceed 3000 feet.

### 2.3 TERMINALS

2.3.1 Terminals should determine the best option for interfacing the barge/terminal connection system with their emergency shutdown system (intrinsically safe electrical, fiber optic, radio, or pneumatic means may be technically feasible). Whatever interface system is used by the terminal, the barge/terminal connection system must be intrinsically safe electrical and the integrated barge/terminal system should permit an overfill protection signal on the barge to activate the terminal emergency shutdown system without delay.

2.3.2 The ground pin on the terminal's plug should be connected to the terminal cable shield which should be grounded at the overfill protection control panel.

2.3.3. The intrinsically safe associated apparatus of the terminal's overfill protection control panel should be designed within the following constraints:

1. Maximum length of terminal cable (panel to connector): 1000 feet.
2. Maximum output voltage (panel): 20.66 volts DC.
3. Maximum output current (panel): 155 mA.
4. Maximum allowable connected inductance (barge circuit): 0.6 mH.
5. Maximum allowable connected capacitance (barge circuit): 0.18 pF.

### 2.4 ELECTRICAL CONNECTION

#### 2.4.1 TANK BARGES

Tank barges should provide a mechanically protected, shielded multicable 2x18 AWG minimum (or U18 AWG minimum if optional high level system is used) with an oil and seawater resistant jacket, terminating in a fixed, male, 5-wire, earthing-contact position 1, 16 amp inlet meeting IEC 309-1/309-2, located within 10 feet of the barge cargo loading manifolds (port and starboard). The inlet should be clearly labeled as follows:



## API RECOMMENDED PRACTICE 1125 *(continued)*

### BARGE OVERFILL CONTROL SYS. CONNECTOR

MAX. INPUT VOLTAGE: 20.66 V DC MAX. INPUT CURRENT: 155 mA

TOTAL CONNECTED INDUCTANCE: \_\_\_\_\_ mH

TOTAL CONNECTED CAPACITANCE: \_\_\_\_\_  $\mu$ F

NOTE: The values to be inserted for total connected inductance and capacitance apply to switches and cabling aboard the barge.

#### 2.4.2 TERMINALS

Terminals should provide a mechanically protected, shielded, flexible cable 2 x18 AWG minimum or 4x18 AWG minimum if optional high level alarm system is used with an oil and seawater resistant jacket, terminating in a female, 5-wire, earthing-contact position 1, 16 amp connector meeting IEC 309-1/309-2. The terminal should provide cable to reach the fixed male connector at the barge manifold with sufficient excess to allow for changing draft, water depth and mooring conditions. The connector should be clearly labeled as follows:

### BARGE OVERFILL CONTROL SYS. CONNECTOR

MAX. OUTPUT VOLTAGE: \_\_\_\_\_ VDC

MAX. OUTPUT CURRENT: \_\_\_\_\_ mA

MAX. ALLOWABLE CONNECTED INDUCTANCE: 0.6 mH

MAX. ALLOWABLE CONNECTED CAPACITANCE: 0.18 \_\_\_\_\_ ( $\mu$ F)

NOTE: The values to be inserted for maximum output voltage and current apply to the intrinsically safe associated apparatus of the terminal's overfill control panel.

#### 2.4.3 CONNECTOR PIN ASSIGNMENTS

Pins N and T3 (L3) are reserved for optional high level alarm connection; pins S2 (L2) and R1(L1) are reserved for emergency shutdown system connections. Pin G (unlabeled in Figure 1) should be connected to the barge cable shield or the terminal cable shield, respectively. Designations N, T, S and R are those found in the current Code of Federal Regulations. Designations shown in parentheses and on Figure 1 are those in the 1989 revision of IEC 309-2.

#### 2.4.4 OPERATIONS

A tank barge's overfill control system should not be Used if its inductance or capacitance exceeds the terminal's design limitations or if the terminal's output voltage or current exceeds the barge's design limitations.



## LIQUID LEVEL CONTROL SYSTEM

ERL manufactures various types of LEVEL ALERT™ Liquid Level Sensors which provide reliable high level and overfill protection in accordance with 46 CFR 39.20-9 (b).

**LEVEL ALERT MODEL II**

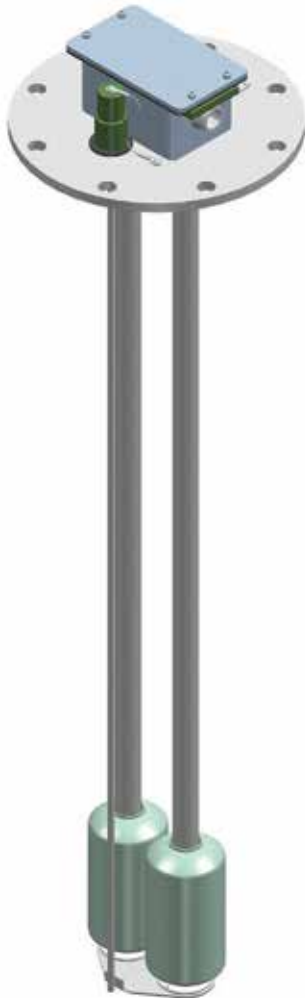

Dual Action float  
with Test Handle.

**LEVEL ALERT MODEL III**

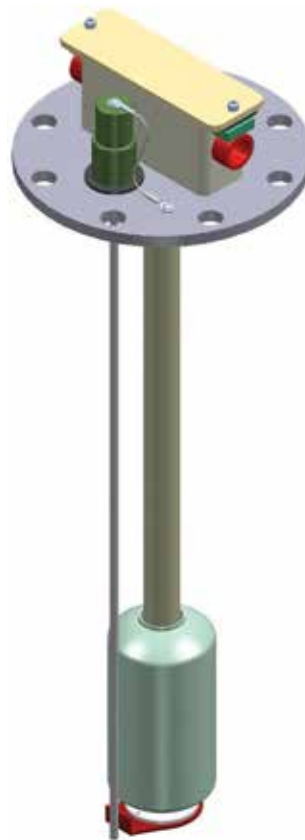

Linear action single float with  
Test Handle.

**LEVEL ALERT RSA**



• We manufacture different types of Liquid Level Sensors, because not all cargos and all vessel requirements are the same. Each type offers unique advantages for different cargos and different vessel configurations. All ERL Liquid Level Sensors are 100% compatible with all other ERL Liquid Level Control System Components and will integrate seamlessly no matter what your particular needs are. The following pages describe the various components of the ERL Liquid Level Control System.

### HIGH LEVEL AND OVERFILL LIQUID LEVEL SENSOR DIMENSIONS

When ordering ERL Liquid Level Alarm Sensors, please provide the dimensional information indicated on the appropriate barge diagram below. This information is necessary to insure that your alarm sensors are manufactured to function at the correct high level and overfill depth settings to adequately protect your crew, cargo and barge. This information should be provided by the engineer who submitted the barge's plans to the Coast Guard. Also, specify the Specific Gravity range (highest and lowest specific gravities) of the cargos being transported in each barge for which you are ordering alarms. All factory alarm settings are relative to a specific gravity of 1.0 S.G.

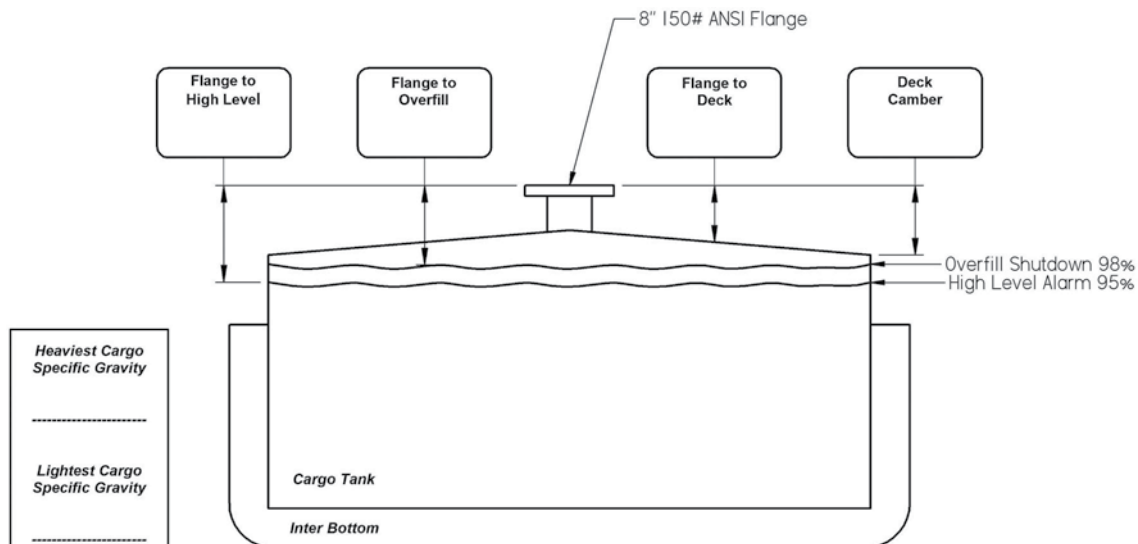

Barge Cross-Section without Centerline Bulkhead

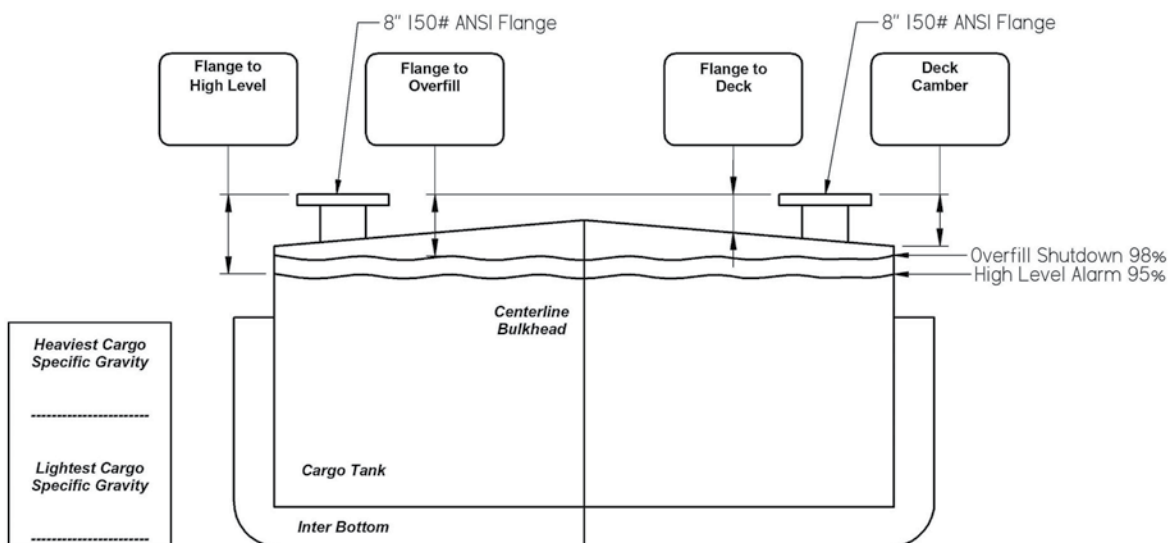

Barge Cross-Section with Centerline Bulkhead



## HIGH LEVEL/OVERFILL LIQUID LEVEL ALARM SENSORS LEVEL ALERT MODEL II™

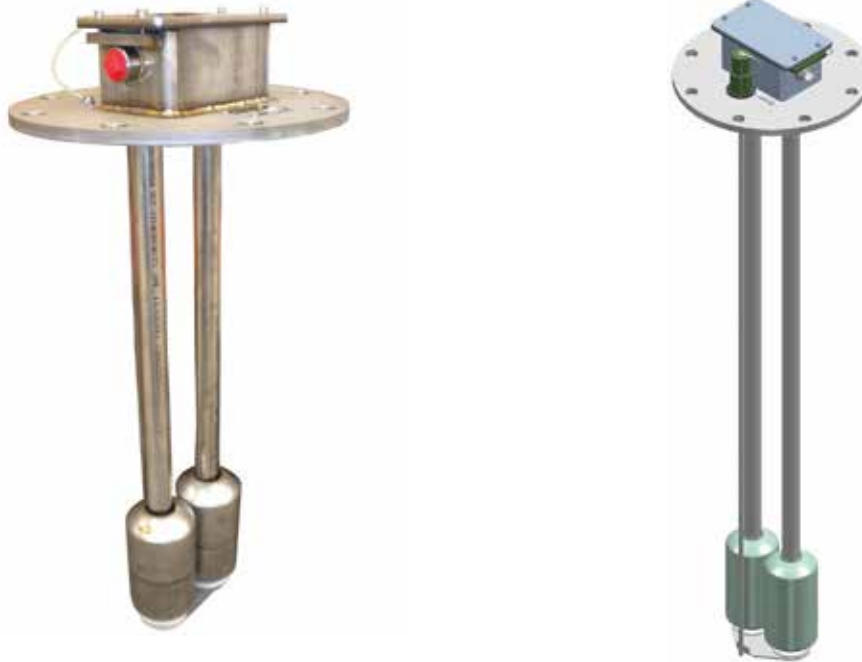

- **FULL REGULATORY COMPLIANCE**

ERL's Level Alert Model II High Level/Overfill Liquid Level Sensor is U.S. Coast Guard accepted and satisfies the requirements of 46 CFR 39.20 - 9 (b). Level Alert sensors are suitable for use on A.B.C. classed vessels.

- **SIMPLE, RELIABLE OPERATION**

Stainless steel linear slide floats actuate the liquid level switches. The high level switch actuates (opens) when the cargo compartment is 95% full. Subsequently the overfill switch actuates (opens) when the cargo compartment is 98% full. With the Level Alert Model II Liquid Level Sensor connected to the loading dock's alarm/shutdown system and/or to barge mounted alarm annunciator panel, the risk of overfill spills are significantly reduced.

- **QUALITY CONSTRUCTION**

All stainless steel heavy duty construction insures extended service in harsh marine applications. Premium ALNICO magnets are tested and matched to ERL's UL approved reed switches for long term reliable operation. Each sensor is 100% operationally tested prior to shipment.

- **EASY INSTALLATION**

Level Alert sensors easily bolt to standard 8" 150 lb. class mounting flanges which are 13.5" diameter with 8-bolt holes 0.88" diameter on a 11.75" diameter bolt circle. The floats can pass through a 7" diameter, or greater, deck opening. The 8" mounting nozzle is typically 6" high and is located at, or near, the geometric center of the cargo compartment. ERL can provide, as optional extras, pre-fabricated mounting nozzles, gaskets and stainless steel bolt sets.

### HIGH LEVEL/OVERFILL LIQUID LEVEL ALARM SENSORS LEVEL ALERT MODEL II™ OPERATIONAL TEST PROCEDURES

**IMPORTANT:** These instructions must be included in transfer procedures of all vessels so equipped. The Test Procedure outlined below must be performed on ALL High Level/Overfill Alarm Sensors prior to EVERY vessel loading per 46 CFR 39.20-9(b)3.

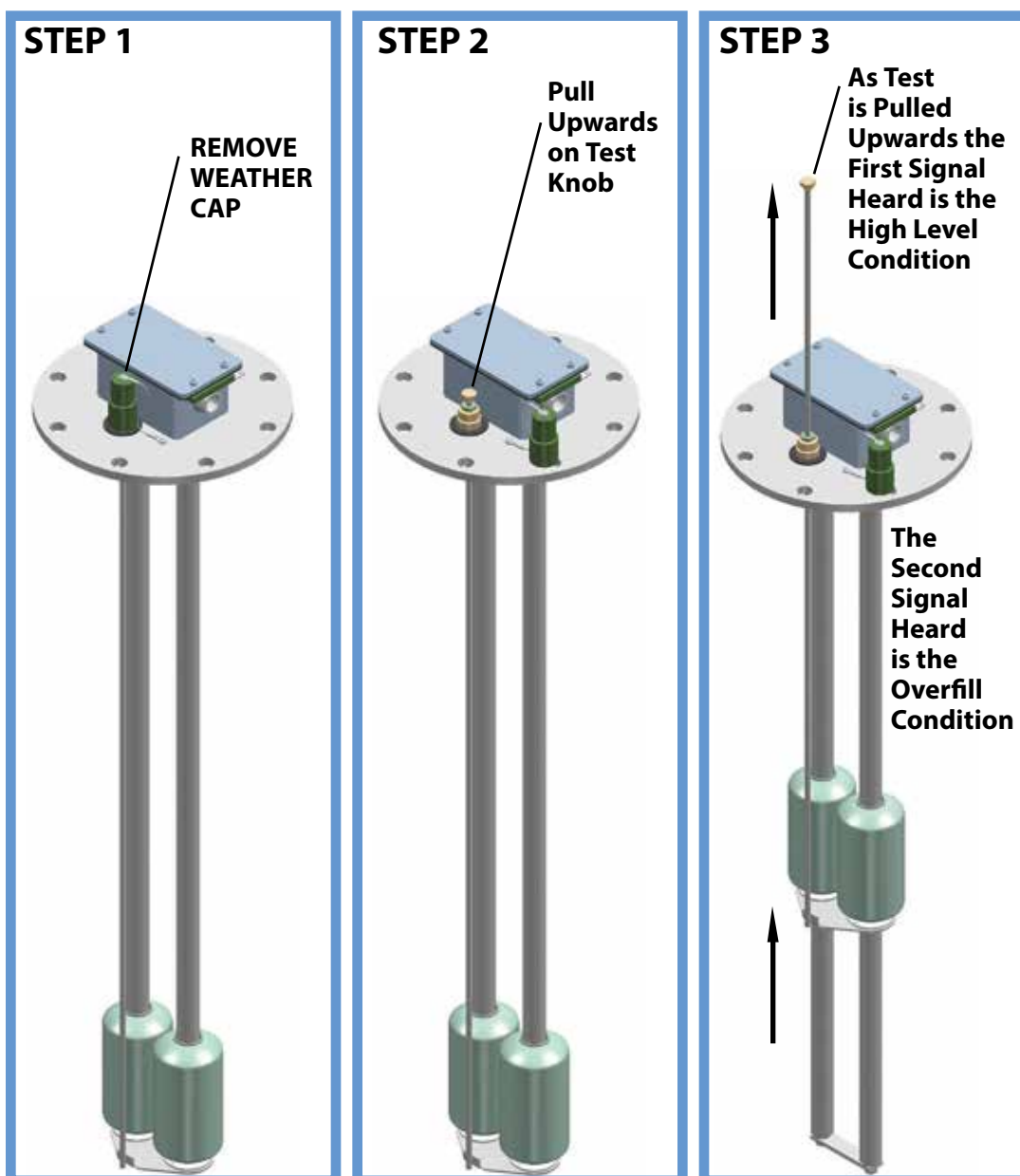



# HIGH LEVEL/OVERFILL LIQUID LEVEL ALARM SENSORS LEVEL ALERT MODEL II™ LEVEL SET POINT CHECK PROCEDURE

## STEP 1



## STEP 2

RAISE TEST ROD AS HIGH AS POSSIBLE. MEASURE THE DIFFERENCE BETWEEN THE MARK MADE AT THE TRIP POINT AND WITH TEST ROD FULLY RAISED. ADD 3-3/4" TO THIS MEASUREMENT TO FIND THE ALARMS SET POINT FROM FLANGE DOWN TO THE LIQUID. DO ONCE FOR "HIGH LEVEL" AND ONCE FOR "OVERFILL" SETTING

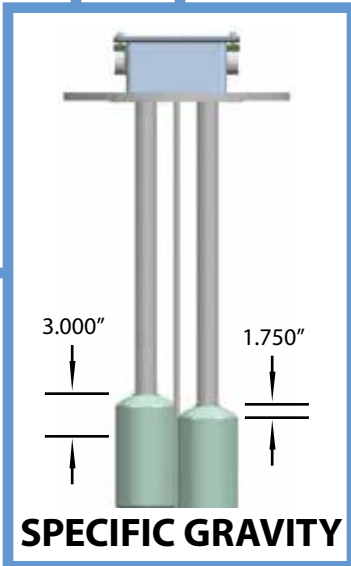
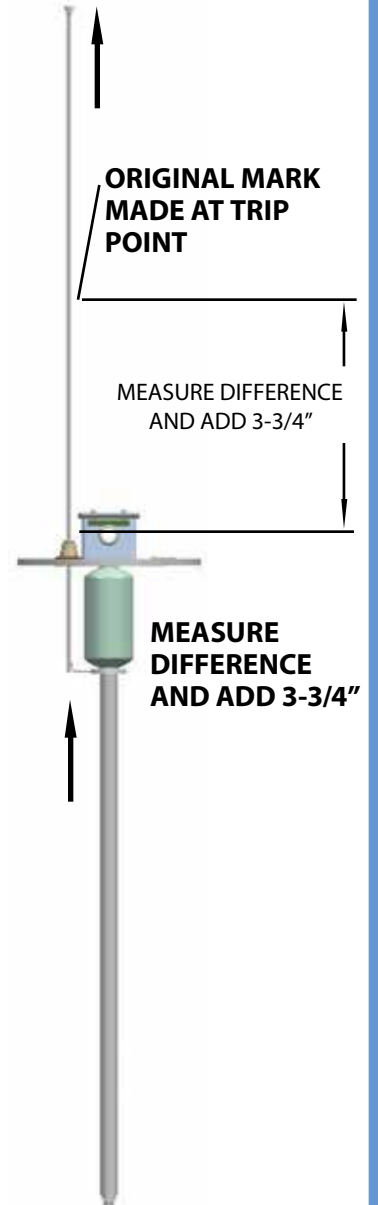

### HIGH LEVEL/OVERFILL LIQUID LEVEL ALARM SENSORS LEVEL ALERT MODEL II™ ASSEMBLY DRAWING

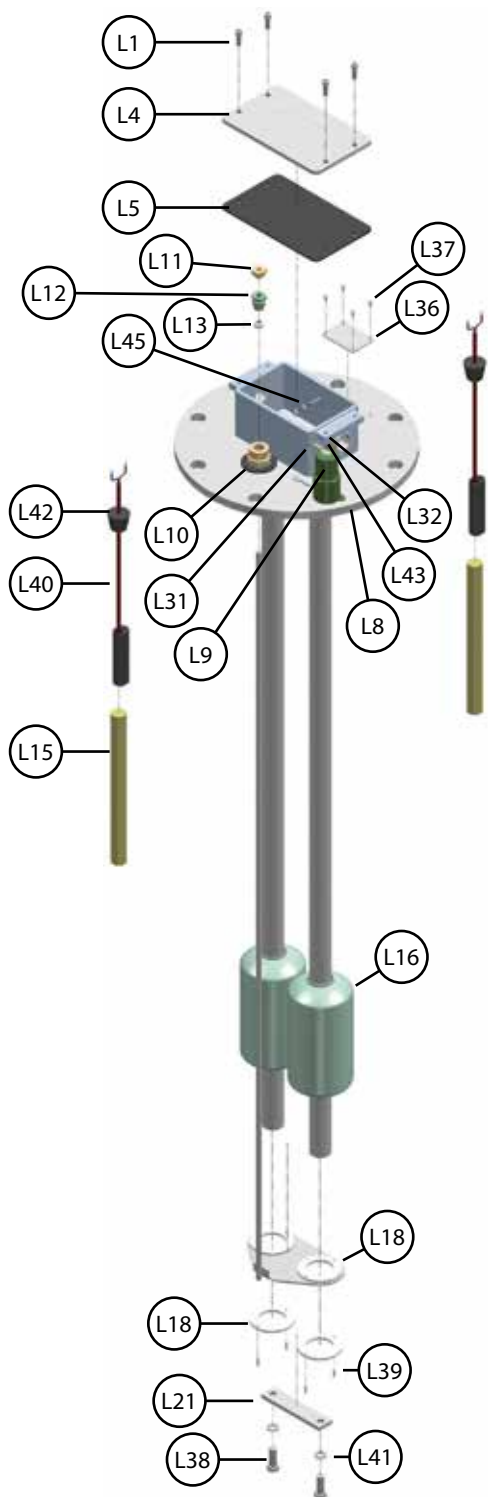

Item No.	Item Name	QTY.
L1	SHCS 1/4-20 x 3/4	4
L4	Junction Box Lid	1
L5	Lid Gasket	1
L8	Mounting Flange	1
L9	Cap	1
L10	Gasket	1
L11	Test Knob	1
L12	Test Rod Guide Bushing	1
L13	Teflon Bushing	1
L15	Spacer	2
L16	Float	2
L18	Test Plate Bumper	4
L19	Test Rod	1
L21	Strap	1
L31	Lanyard	1
L32	Drive Screw	2
L36	ID Tag	1
L37	Drive Screw	4
L38	Hex Head Bolt	2
L39	Rivit	4
L40	Switch Assm.	2
L41	Lockwasher	2
L42	Switch Assm. Plug	2
L43	Washer	1
L45	Hex Nut	2

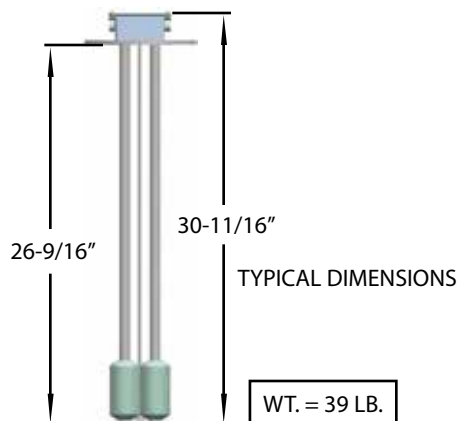





## HIGH LEVEL/OVERFILL LIQUID LEVEL ALARM SENSORS LEVEL ALERT™ MODEL E-III

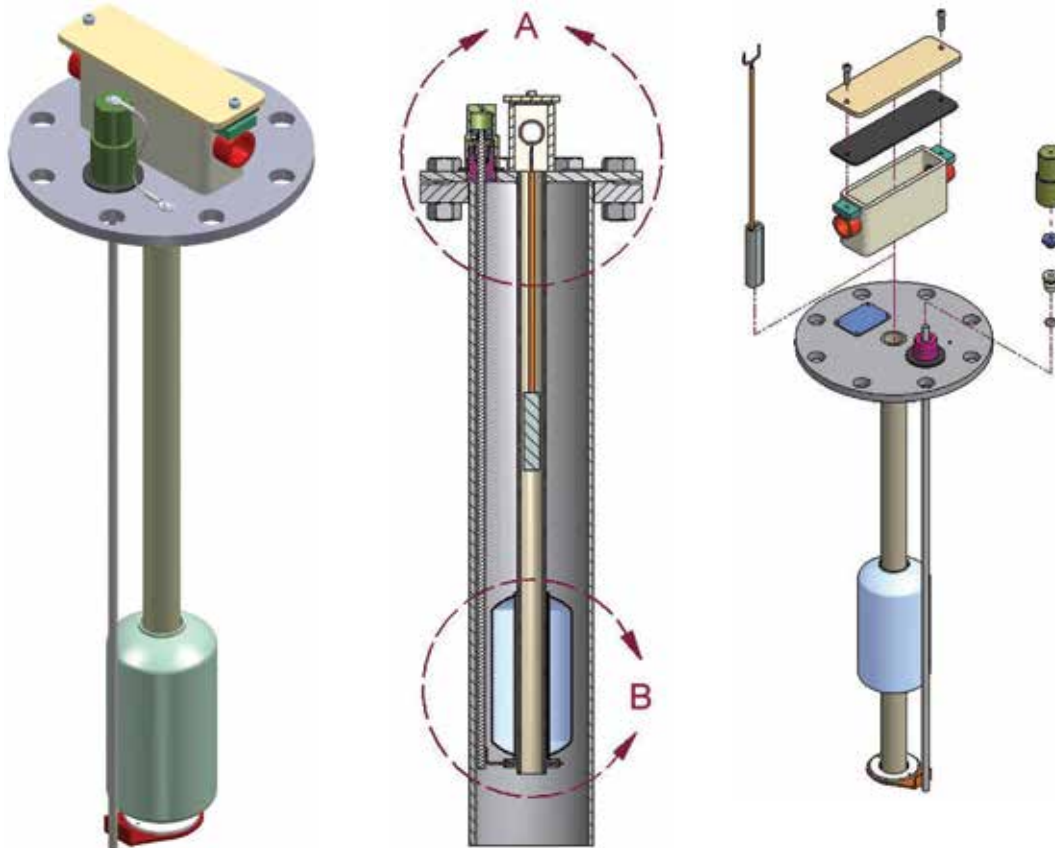

- **FULL REGULATORY COMPLIANCE**

ERL's Level Alert Model E-III High Level/Overfill Liquid Level Sensor is U.S. Coast Guard accepted and satisfies the requirements of 46 CFR 39.20 - 9 (b). Level Alert sensors are suitable for use on A.B.C. classed vessels.

- **SIMPLE OPERATION**

A single stainless steel linear slide float actuates (opens) Liquid Level Switches on common tube as liquid rises.

- **QUALITY CONSTRUCTION**

All 300 series stainless steel construction insures extended service life. Premium ALNICO float magnets are tested and matched to ERL's UL Approved Reed Switches for long term reliable operation. Each sensor is 100% operationally tested prior to shipment.

- **EASY INSTALLATION**

The Level Alert E-III bolts to standard 5" 150 lb. class mounting flange which is 11.0" diameter and has (8) 0.88" diameter bolt hole on a 9.5" diameter bolt circle. The floats passing through a 5" diameter deck opening.

## RSA - RISING STICK ALARM



- **FULL REGULATORY COMPLIANCE**

The Rising Stick Alarm (RSA) is U.S. Coast Guard accepted. It satisfies 46 CFR 39.20 3(b), 39.20-(b), as well as OPA 90 regulations for overfill devices and is suitable for use on ABS classed vessels. The RSA utilizes the ERL L-40 alarm Reed switch which carries a UL approval for use in hazardous cargo locations.

- **SAFETY**

Personnel are not exposed to hazardous cargo vapors on the tank top when using the reliable RSA Liquid Level Gauge. The hazard of overfill spills is greatly reduced when properly using the RSA. The RSA alarm operation can be checked by removing the weather cap, and lifting the stick until the High Level and Overfill alarms annunciate.

- **EASY INSTALLATION**

Simply bolt the RSA to an 8" Class 150 flanged pipe stand located at or near the geometric center of the cargo compartment. The deck opening must be large enough for the 7" dia. float to pass through.

- **HEAVY DUTY CONSTRUCTION**

All welded components are 300 series stainless steel. Powerful NEODYMIUM #38 rod magnets are used to insure superior coupling strength between the CERAMIN #8 float magnet and the tri-colored gauge rod. The tri-colored gauge rod, color coded to industry standards, is hermetically sealed by design, to provide extended service life.

- **SIMPLE, RELIABLE OPERATION**

Stainless steel linear slide floats actuate the liquid level switches. The high level switch actuates (opens) when the cargo compartment is 95% full. Subsequently the overfill switch actuates (opens) when the cargo compartment is 98% full. With the Rising Stick Alarm connected to the loading dock's alarm/shutdown system and/or to barge mounted alarm annunciator panel, the risk of overfill spills are significantly reduced.



### LIQUID LEVEL CONTROL SYSTEM SYSTEM ACCESSORIES (Per 46 CFR 39.20 – 9 (b))

#### Barge-to-Shore Receptacles



**BTS-1** – HUBBELL receptacle, Junction Box, Enclosure, and BCS-001 sticker.  
2 required – 1 Port and 1 Starboard



**BTS-2** – HUBBELL receptacle, Junction Box, and cap.  
2 required – 1 Port & 1 Starboard



**BTS-3** – HUBBELL receptacle, Junction Box, and cap.  
2 required – 1 Port & 1 Starboard

#### Shore-to-Barge Plug



Item 516P

Item 516C

HUBBELL PLUGS – item 516C with weather cover is the standard connector for our APM-1.



**BARGE CONNECTOR SIGN - BCS-001**  
Designed to identify the location of the barge overflow alarm system electrical connector. Dimensions: 7" X 11" and contains all information required including a space for the system inductance rating in millihenrys and the system capacitance in microfarads.

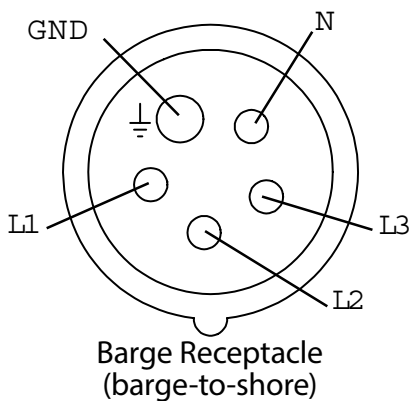

Legend	
GND	= Ground
L1	= Overfill
L2	= Overfill
L3	= High Level
N	= High Level

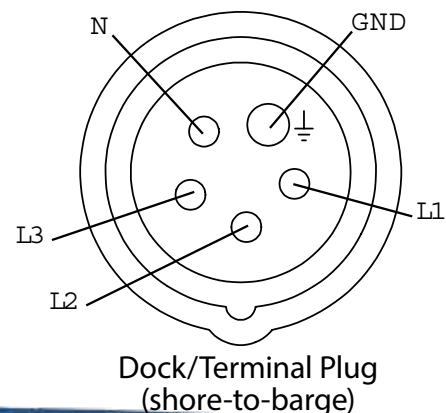

### BARGE TO SHORE CONNECTION BTS ASSEMBLY DRAWINGS

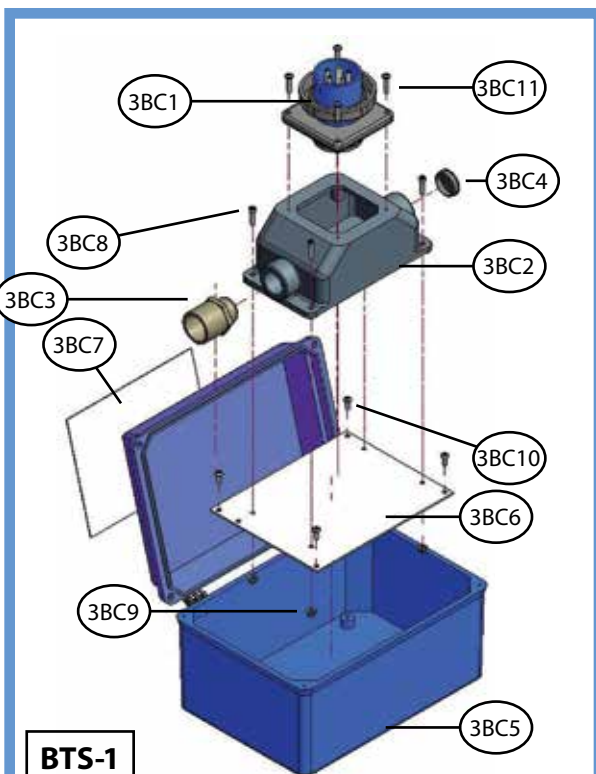

**BTS-1**

Item #	DESCRIPTION	QTY PER
3BC1	Receptacle 516B1W	1
3BC2	Junction Box FT302W	1
3BC3	Connector	1
3BC4	Pipe Plug, 1 Inch	1
3BC5	Enclosure	1
3BC6	Mounting Plate Hoffman A-10P8	1
3BC7	BCS-001 Sticker	1
3BC8	SHCS, 10-32 x 7/8	4
3BC9	Nylock Nut, 10-32	4
3BC10	BHCS, 10-32 x 3/8	4
3BC11	Machine Screw, 10-32 x 7/8	4

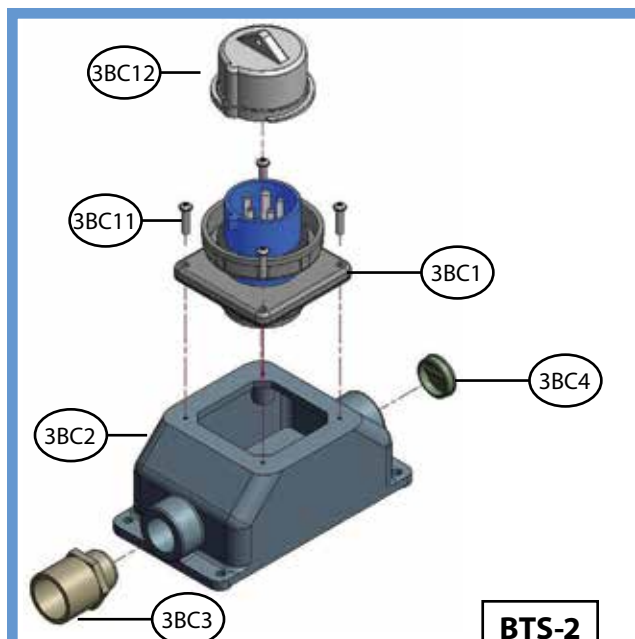

**BTS-2**

Item #	DESCRIPTION	QTY PER
3BC1	Receptacle 516B1W	1
3BC2	Junction Box FT302W	1
3BC3	Connector	1
3BC4	Pipe Plug, 1 Inch	1
3BC11	Machine Screw, 10-32 x 7/8	4
3BC12	Cap PC520	1

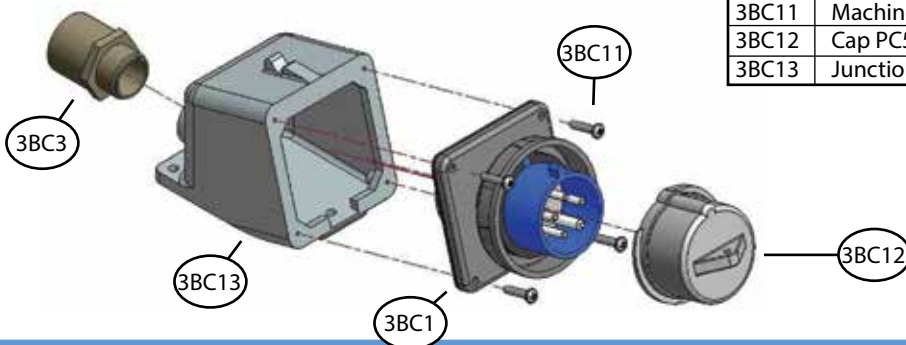

**BTS-3**

Item #	DESCRIPTION	QTY PER
3BC1	Receptacle 516B1W	1
3BC3	Connector	1
3BC11	Machine Screw, 10-32 x 7/8	4
3BC12	Cap PC520	1
3BC13	Junction Box BB201W	1



# TYPICAL SERIES WIRING DIAGRAMS

Per 46 CFR 39.20 - 9 (b) 6

Installation practices per 46 CFR Part 111.105 for hazardous locations must be followed as well as API 1125. Recommended wire is TPS16TIB-1; 2-Conductor, 16 Gauge, bronze armor, foil shield with 20 gauge ground wire or equal.

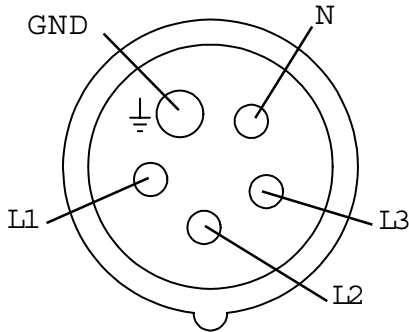

Barge Receptacle (barge-to-shore)

Legend	
GND	= Ground
L1	= Overfill
L2	= Overfill
L3	= High Level
N	= High Level

CONNECT HUBBELL RECEPTACLE GROUND TO HULL

REED SWITCH  
UL APPROVAL NO. E122752 (N)  
CAPACITANCE 0.2 PICO FARADS  
INDUCTANCE 0

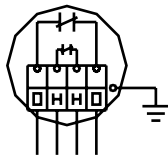

FIELD CONNECTION TO SENSOR

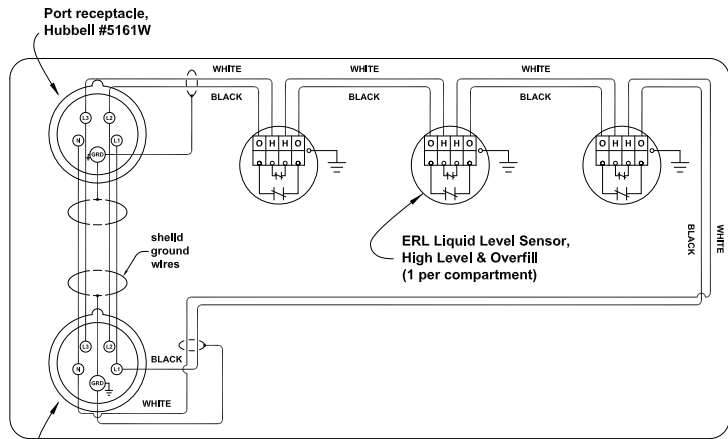

Starboard receptacle, Hubbell #5161W

Port receptacle, Hubbell #5161W

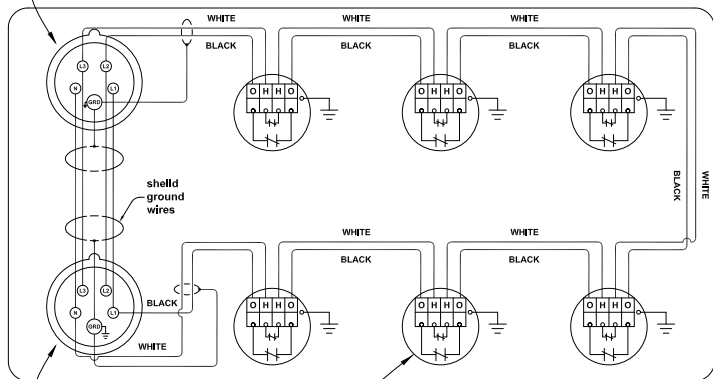

Starboard receptacle, Hubbell #5161W

ERL Liquid Level Sensor, High Level & Overfill (1 per compartment)

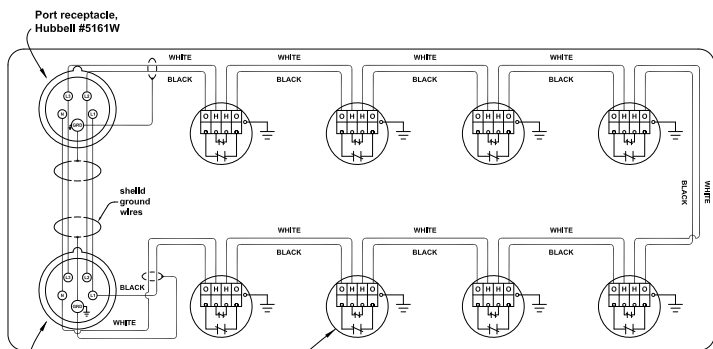

Starboard receptacle, Hubbell #5161W

ERL Liquid Level Sensor, High Level & Overfill (1 per compartment)

\* BARGE TO SHORE HUBBELL RECEPTACLES MUST BE LOCATED WITHIN 10 FEET OF CARGO LOADING MANIFOLDS (PORT AND STARBOARD).

### TYPICAL SERIES WIRING DIAGRAMS

Per 46 CFR 39.20 - 9 (b) 6

Installation practices per 46 CFR Part 111.105 for hazardous locations must be followed as well as API 1125. Recommended wire is TPS16TIB-1; 2-Conductor, 16 Gauge, bronze armor, foil shield with 20 gauge ground wire or equal.

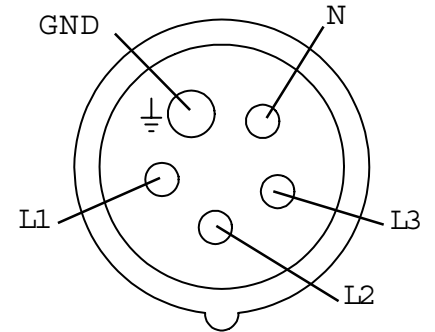
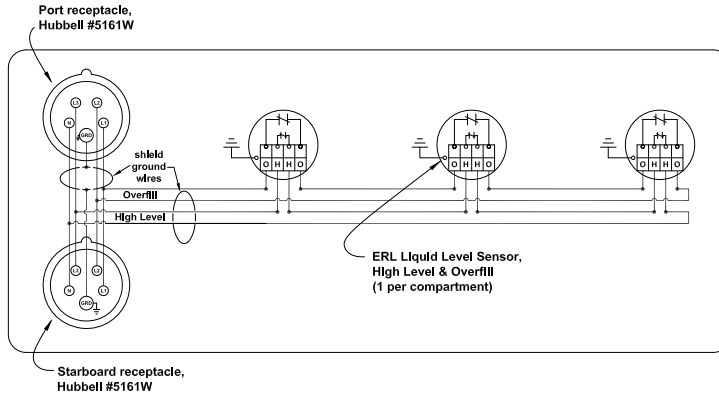

Barge Receptacle (barge-to-shore)

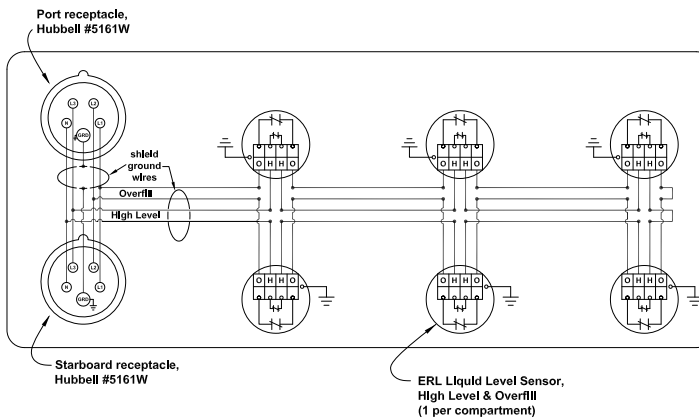

Legend	
GND	= Ground
L1	= Overfill
L2	= Overfill
L3	= High Level
N	= High Level

CONNECT HUBBELL RECEPTACLE GROUND TO HULL

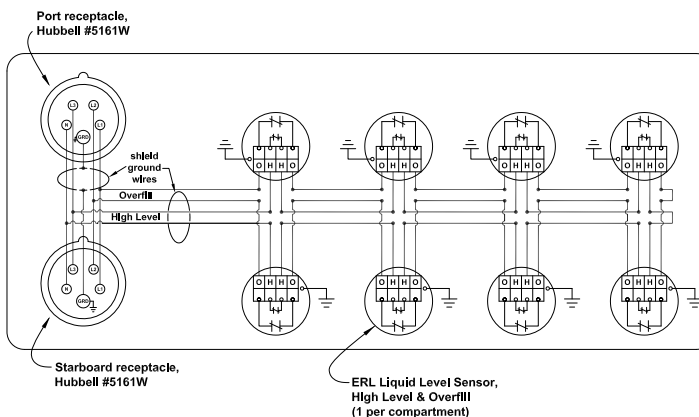

REED SWITCH  
UL APPROVAL NO. E122752 (N)  
CAPACITANCE 0.2 PICO FARADS  
INDUCTANCE 0

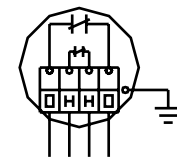

FIELD CONNECTION TO SENSOR



# HIGH LEVEL/OVERFILL ALARM SENSOR WIRING INTERCONNECT BOX

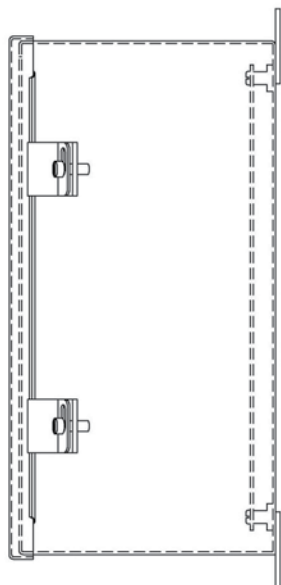
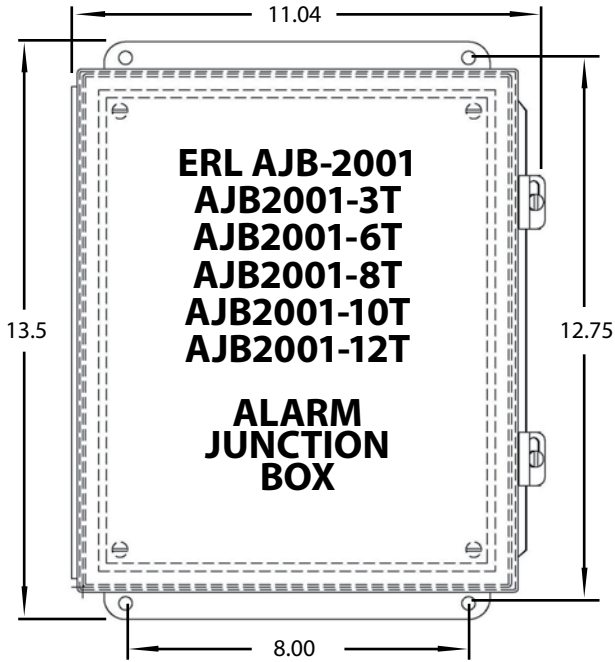

**STAINLESS STEEL CONSTRUCTION**

**NEMA 4R**

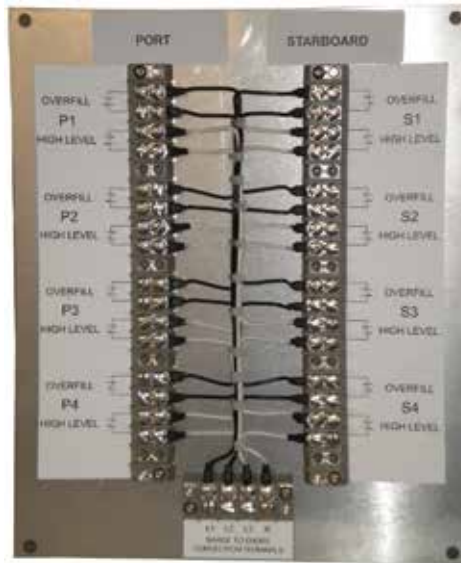
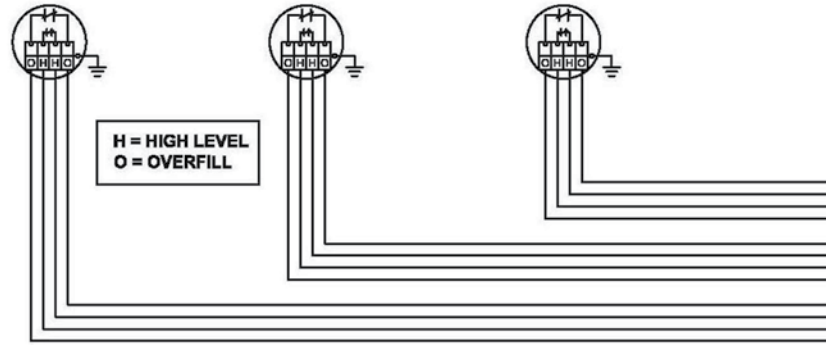

THE HIGH LEVEL/OVERFILL SENSORS ARE LOCATED IN A CLASS 1, GROUP D, HAZARDOUS LOCATION. THESE N/C CONTACTS ARE CONNECTED IN SERIES. INSTALLATION PRACTICES PER 46 CFR PART 111.105 FOR HAZARDOUS LOCATIONS MUST BE FOLLOWED AS WELL AS API 1125. RECOMMENDED WIRE IS TPS16TIB-2 OR EQUAL; 4-CONDUCTOR, 16 GAUGE, BRONZE ARMOR, FOIL SHIELD WITH 20 GAUGE GROUND WIRE OR EQUAL. FTNSIA 16 GAUGE, 4 CONDUCTOR CABLE WITH COPPER SHIELD AND ALUMINUM ARMOR. CONNECT GROUND WIRE TO HULL.

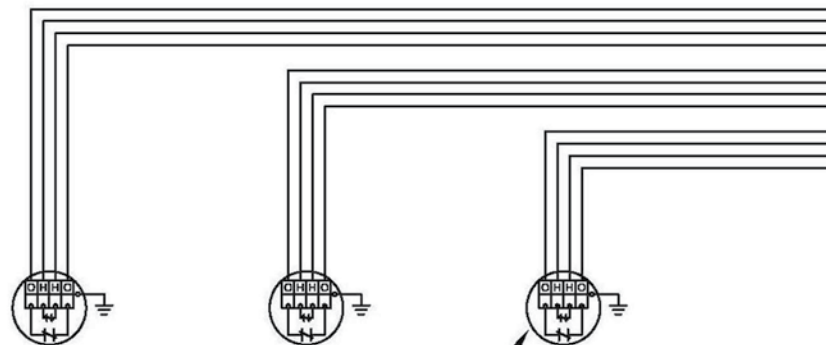

ERL Liquid Level Sensor, High Level & Overfill (1 per compartment)

### HIGH LEVEL/OVERFILL ALARM SENSOR WIRING INTERCONNECT BOX

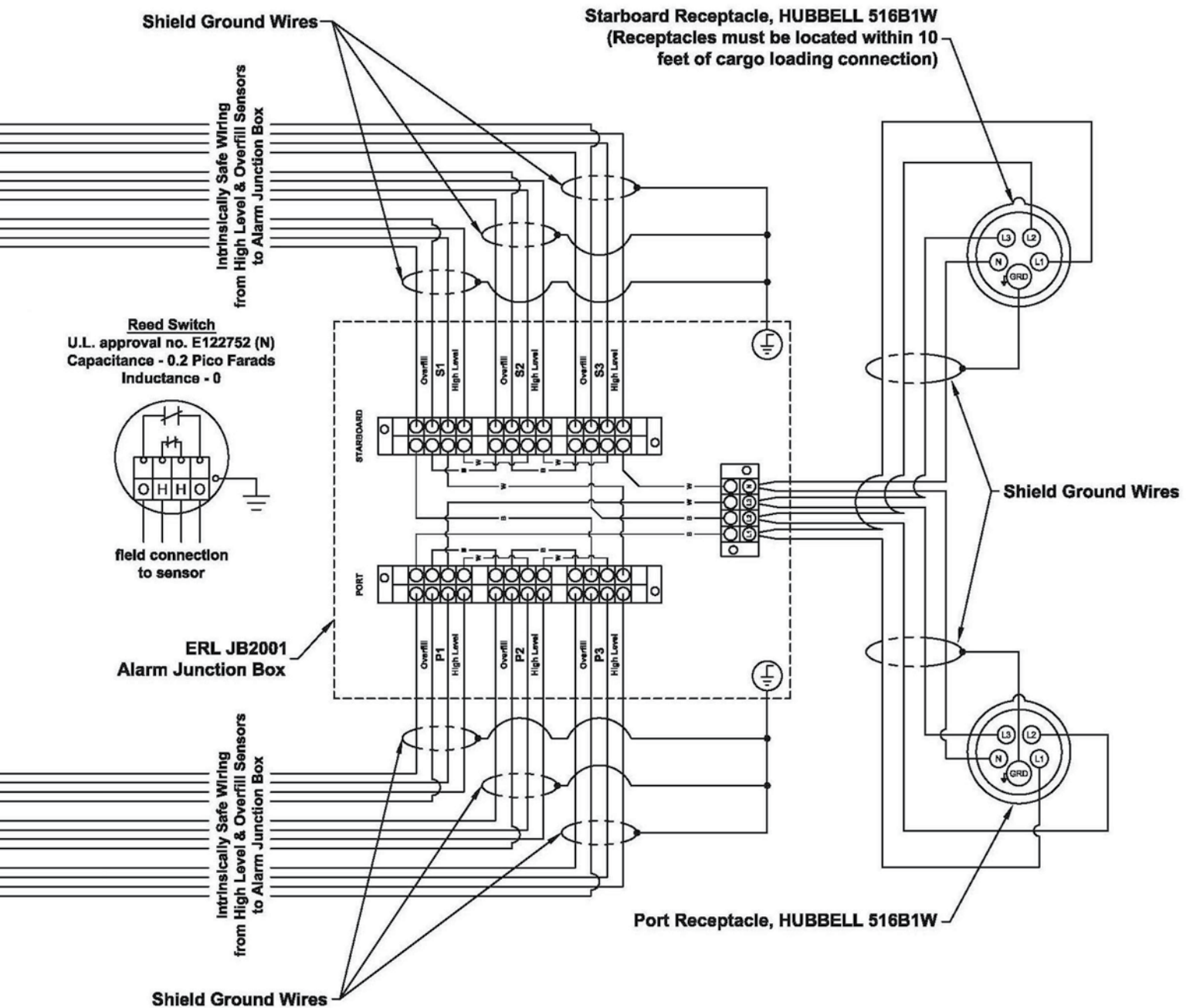

CONNECT HUBBELL RECEPTACLE AND JUNCTION BOX GROUND TO HULL.





## PORTABLE ALARM PANEL MODEL APM-1B LITE



- **PORTABLE AND COMPLETELY SELF CONTAINED**

ERL's APM-1B Lite is very portable, weighing 18 lbs. The unit is battery powered with a self-contained panel and the handle makes for easy portability. A voltmeter lets you monitor battery condition when the switch is in the "ON" position.

- **SAFE RELIABLE OPERATION**

The APM-1B Lite is housed in a weather proof enclosure rated for outdoor use. The output of the APM-1B Lite is intrinsically safe for connection in Class I, II, and III, Division 1 and 2, Groups A-G Hazardous Locations.

- **EASY TO OPERATE**

With a long cable attached to a Hubbell 516C-1W receptacle, the APM-1B Lite allows for easy connection to the vessel liquid level sensor system with the panel positioned outside for the hazardous area. Brilliant indicator lights and a loud audible alarm warns the tankerman of a high level/overfill condition over the entire barge.

### PORTABLE ALARM PANEL MODEL APM-1B

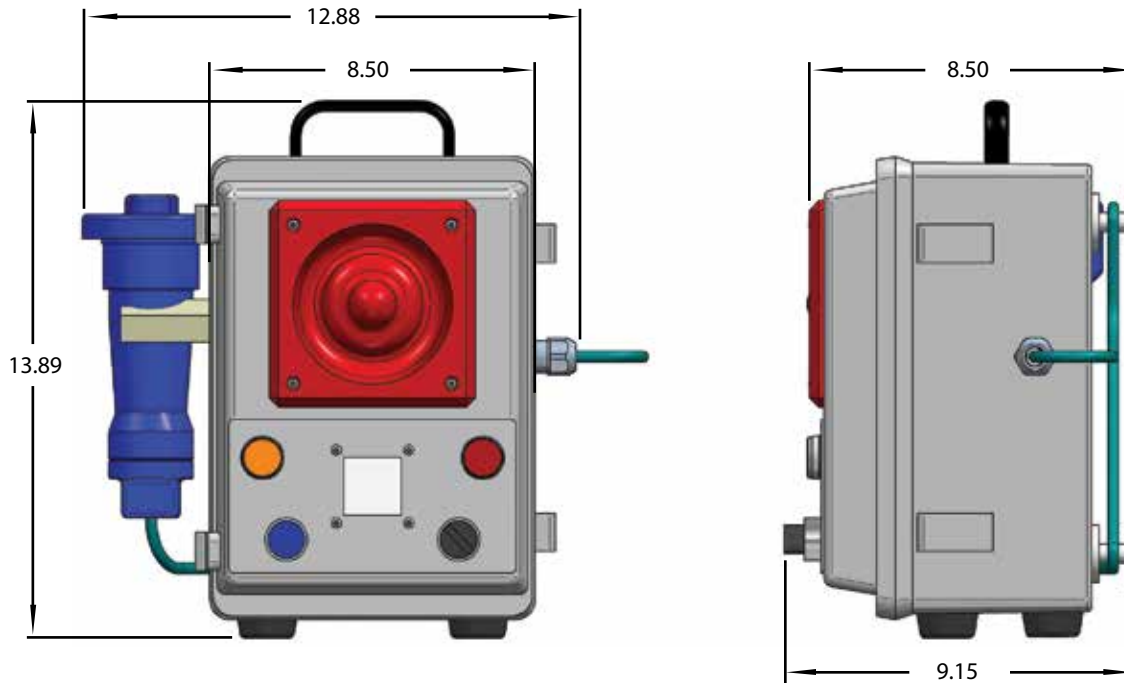

**APM-1B Lite**  
WT = 18 lbs

## **PORTABLE ALARM PANEL APM 1TLB**

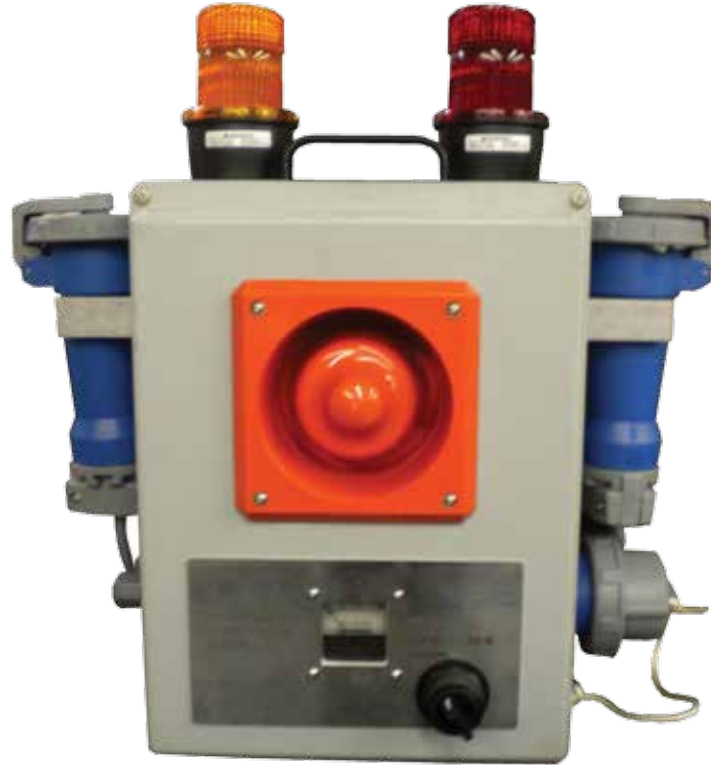

- **PORTABLE AND COMPLETELY SELF CONTAINED**

The APM-1-Tandem Loading Box is a portable self contained alarm notification panel which allows for connection to one or two liquid level sensor systems on a vessel outside the hazardous area. The panel contains two Hubbell 516C-1W female connectors attached to the unit for connection to the Male Hubbell Plug attached to the barge. A Hubbell 516B-1W male connect is mounted on the side of the unit allowing for multiple barge loading and monitoring.

- **SELF RELIABLE OPERATION**

The APM-1TLB is housed in a weather proof enclosure for outdoor use. The output of the APM-1TLB is intrinsically safe for connection in Class I, II, and III, Division 1 and 2, Groups A-G Hazardous Locations.

- **EASY TO OPERATE**

With a long cables attached to a Hubbell 516C-1W receptacle, the APM-1TLB allows for easy connection to the vessel liquid level sensor system with the panel positioned outside for the hazardous area. A brilliant Amber (High Level) and Red (Overfill) strobe lights sit on top the unit with an audible (Yodel) alarm (rated 105 D.B. at 1 meter) mounted in the front of the unit warns the tankerman of a high level/overfill condition over the entire barge(s). The 24 Volt System operates on (2) 5000 mah re-chargeable batteries with 50 hrs lifetime per charge. A voltmeter is mounted on the face of the unit to verify voltage levels (note: a minimum of 21 volts is required for proper operation). A single/tandem switch allows the panel to be used for single or tandem loadings.

## FIXED ALARM PANELS MODEL APM-2



- **FULL REGULATORY COMPLIANCE**

ERL's APM-2 vessel mounted High Level/Overfill Alarm Annunciator Panel satisfies 46 CFR 39.20 9 (a) when connected to an ERL Liquid Level Sensor System. The installation must conform to 46 CFR 111.105 and API Recommended Practice 1125. The APM-2 Alarm Panel is U.S. Coast Guard accepted and satisfies OPA-90 requirements for overfill protection devices and is suitable for ABS classed vessels.

- **QUALITY CONSTRUCTION**

The APM-2's weatherproof cabinet is 100% heavy gauge stainless steel. All electrical components are UL, FM and CSA approved. Each APM-2 Alarm Panel undergoes complete operational testing and final inspection before shipment.

- **SAFE AND RELIABLE OPERATION**

The annunciator lights on the APM-2 Alarm Panel are displayed in the same layout configuration as the barge's cargo compartments for quick and easy recognition. Amber lights are used to represent a high level alarm and red lights announce an overfill warning. Additionally, an alternating 105 decibel tone indicates a high level alarm while a steady 105 decibel tone signal indicates an overfill warning. The audible signals can be easily heard from any location on the deck.



FIXED ALARM PANELS - APM-2



APM-2-3



APM-2-6



APM-2-8

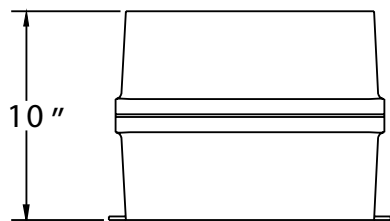
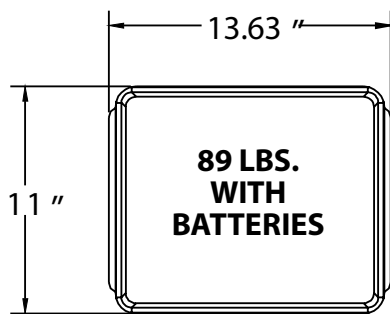

BATTERY BOX



APM-2-10



APM-2-12

### FIXED ALARM PANELS - APM-2 Operation of the APM-2 Audio/Visual Annunciator

The APM-2 tank barge liquid level annunciator panel is 24 VDC battery powered. A stainless steel NEMA/ EEMAC Type 4, 24"H x 16"W x 8"D enclosure houses all electrical components and the batteries are housed in a separate battery box. Although rated for outdoor use, these enclosures are not explosion proof and therefore must be mounted outside of the hazardous area on deck per 46 CFR 111. 105-3 1. More specifically, this panel must be mounted on the open deck a minimum of 10 feet (3 meters) away from the cargo area (vapor source). When mounted over the cargo compartments, the panel must be mounted at least 8 feet over the deck per 46 CFR 111. 105-3 1, K(2).

The APM-2 panel utilizes STAHL Model 9251/02 dual channel intrinsically safe repeater relays, which are UL, FM and CSA approved for intrinsically safe connection in Class I, II and III, Division 1 and 2, Groups A - G hazardous locations. The 8.2 VDC intrinsically safe sensing circuit, of the STAHL 9251/02, safely interfaces the annunciator panel with the normally closed reed switches, which are located in a hazardous location. The UL approved independently operating reed switches are float activated to open at 95% of tank capacity representing HIGH LEVEL ALARM condition and at approximately 98% of tank capacity representing OVERFILL ALARM condition. Each cargo tank is fitted with the aforementioned sensors (switches).

Outwardly, the panel annunciator light layout reflects the cargo compartment configuration with an amber and red light pair representing HIGH LEVEL ALARM and OVERFILL ALARM respectively for each cargo compartment. Additionally, amber High Level Alarm and red Overfill Alarm 2,000,000 C.P. strobe lights sit atop the panel. The front mounted audible alarms for both High Level and Overfill have a continuously rated sound level of 105 D.B. at 1 meter. An on/off rotary switch with power "on" light, battery condition voltmeter and red low power warning light are also located on the front of the panel.

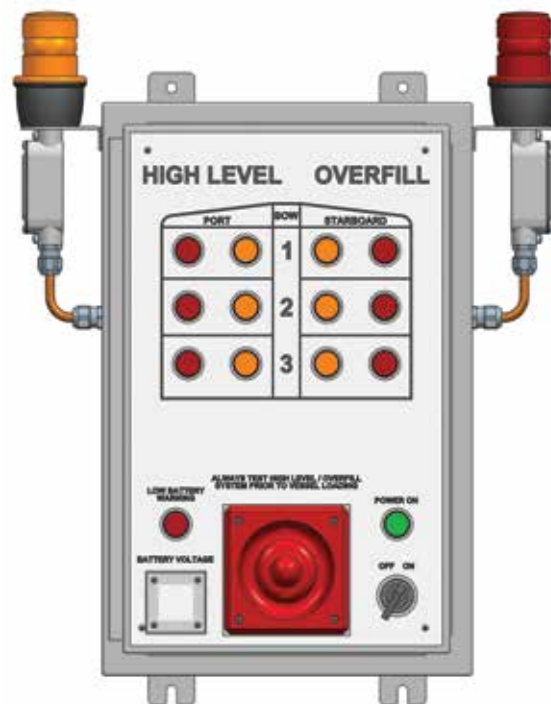

**APM-2-6**

#### PHYSICAL DIMENSIONS

Panel	Weight	Size H - W - D
APM-2 - 3	51 lbs.	34" x 16" x 8"
APM-2 - 6	58 lbs.	34" x 16" x 8"
APM-2 - 8	62 lbs.	34" x 16" x 8"
APM-2 - 10	66 lbs.	34" x 16" x 8"
APM-2 - 12	76 lbs.	40" x 20" x 8"



## FIXED ALARM PANELS - APM-2 Operation of the APM-2 Audio/Visual Annunciator (Continued)

Panel operation is as follows.

When liquid level reaches 95% capacity in a cargo compartment, the high level sensor reed switch protecting that compartment opens, breaking the intrinsically safe sensing loop from its corresponding 9251/02 repeater relay. This relay turns on the amber High Level Alarm light showing which specific compartment has the 95% full condition. Simultaneously, the top mounted yellow strobe light begins to flash and the high level audible signal sounds. After an adjustable time period of approximately 5 seconds, the amber strobe light and high level audible signal will shut off, yet the amber individual compartment High Level indicator light will remain lit. When the first high level condition is achieved, the High Level series loop of dry panel contacts feeding pins L3 and N of the Hubbell 516B-IW Barge to Shore Receptacles open. If the barge is connected to a dock facility, which can accept this signal, the dock will immediately be aware of the High Level condition. In turn, each subsequent high level condition will be announced as describe above.

In the event liquid level reaches 98% capacity, simultaneously the individual compartment red overfill light will light, the red strobe light will light, the overfill audible alarm will sound and the barge to shore connection circuit indicating

overfill alarm will open at pins L1 and L2, alerting the dock facility of the overfill condition if the facility has provisions to accept this signal. All of these system conditions remain until liquid level is reduced or the annunciator panel power switch is turned off. With panel power switched "off" or if the battery power fails, both High Level and Overfill conditions will be indicated at the barge to shore connection receptacles. If the annunciator panel power switch is "on" and battery power drops too low, to a value of approximately 20 VDC, the red low power warning light will come on and the barge to shore connection will indicate both High Level and Overfill conditions.

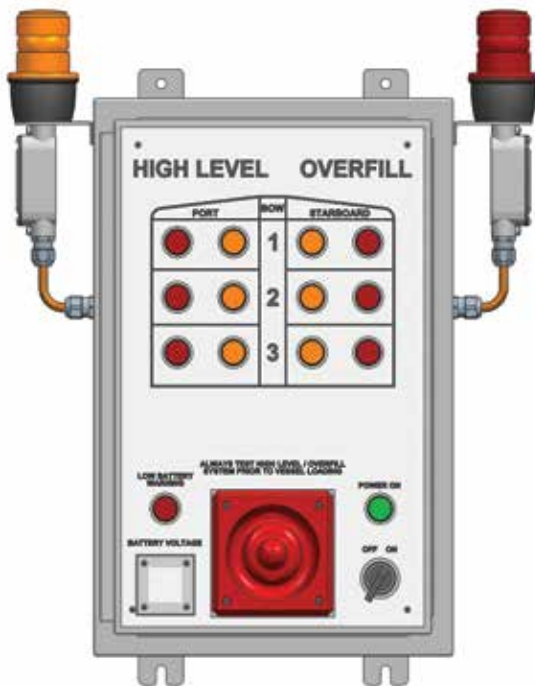

APM-2-6

During pre-transfer overfill system testing as required in 46 CFR 39.20(b)3, all system components are fully tested. During this system test, battery supply voltage is clearly 0-21 indicated and if supply voltage is less than 21 VDC, the two series connected 12 VDC gel cell batteries must be recharged or replaced with fully charged batteries. Approximately 50 hours of panel operation can be expected from a fully charged battery set. As an option, solar modules can be provided to recharge the batteries on the barge making the power supply maintenance free.

### FIXED ALARM PANELS TYPICAL APM-2 WIRING DIAGRAMS

The high level/overflow sensors are located in a Class 1, Division 1, Group D hazardous location. The normally closed contacts are connected to Stahl series 9251/02 intrinsically safe repeater relays which limit voltage at 8.2 VDC. This is an intrinsically safe circuit.

Reed Switch UL Approval No. E122752 (N) SPST Form A Capacitance 0.2 Picofarads - Inductance 0

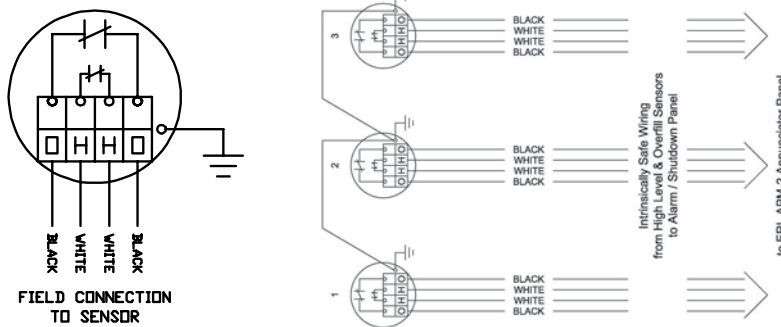

4-conductor 16 gauge bronze armored foil shield with 20 gauge ground wire TPS1 6T1 B-2 or equal.

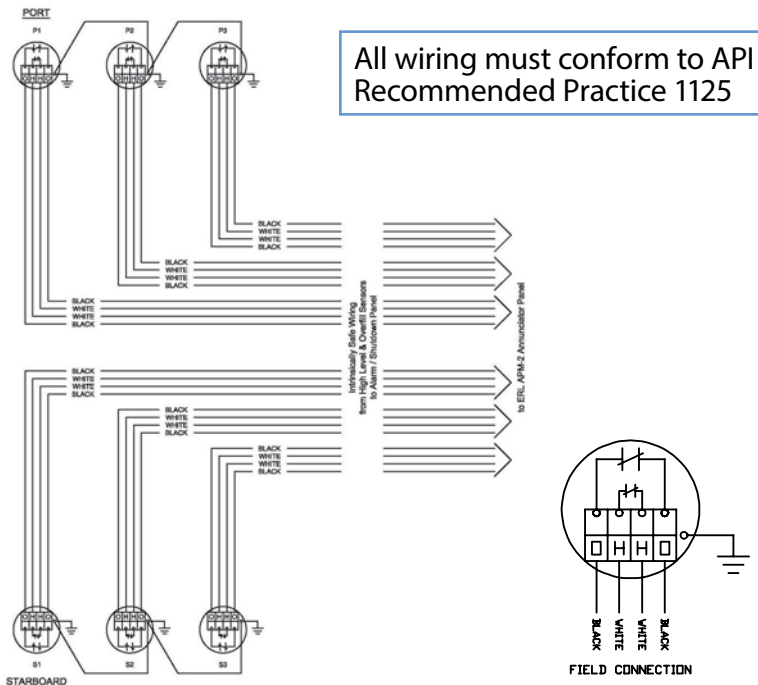

All wiring must conform to API Recommended Practice 1125

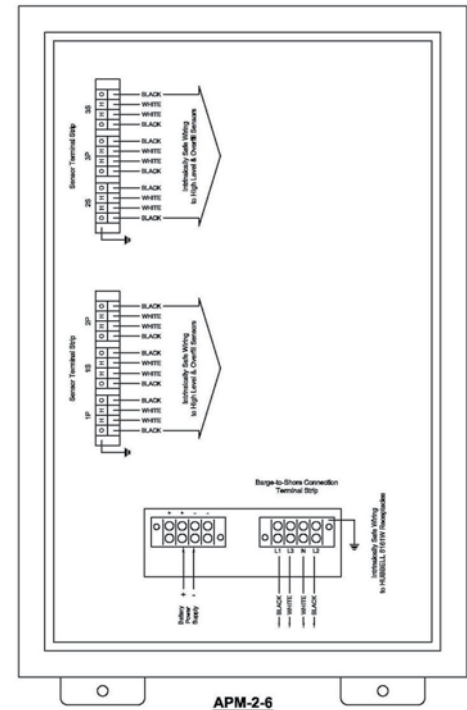
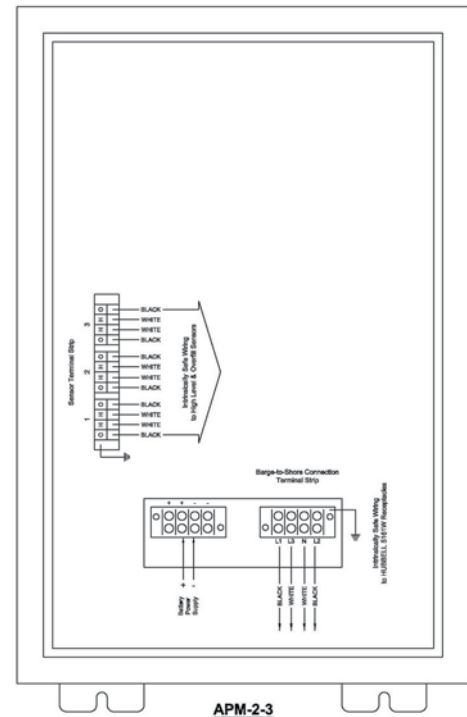





### FIXED ALARM PANELS TYPICAL APM-2 WIRING DIAGRAMS

The high level/overflow sensors are located in a Class 1, Division 1, Group D hazardous location. The normally closed contacts are connected to Stahl series 9251/02 intrinsically safe repeater relays which limit voltage at 8.2 VDC. This is an intrinsically safe circuit.

Reed Switch UL Approval No. E122752 (N) SPST Form A Capacitance 0.2 Picofarads - Inductance 0

4-conductor 16 gauge bronze armored foil shield with 20 gauge ground wire TPS1 6T1 B-2 or equal.

All wiring must conform to API Recommended Practice 1125

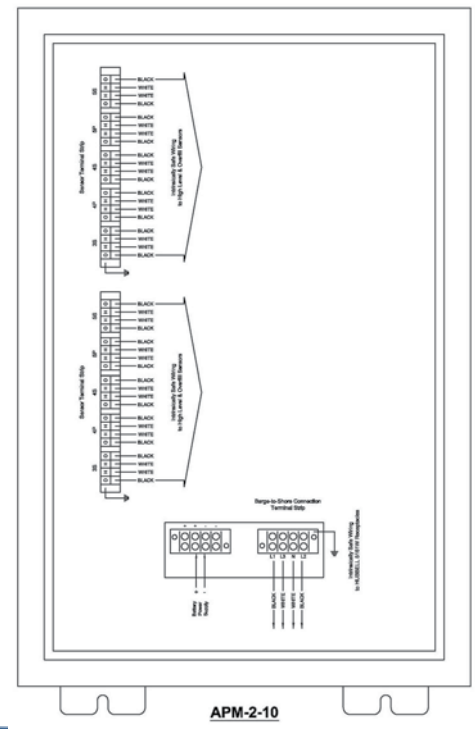
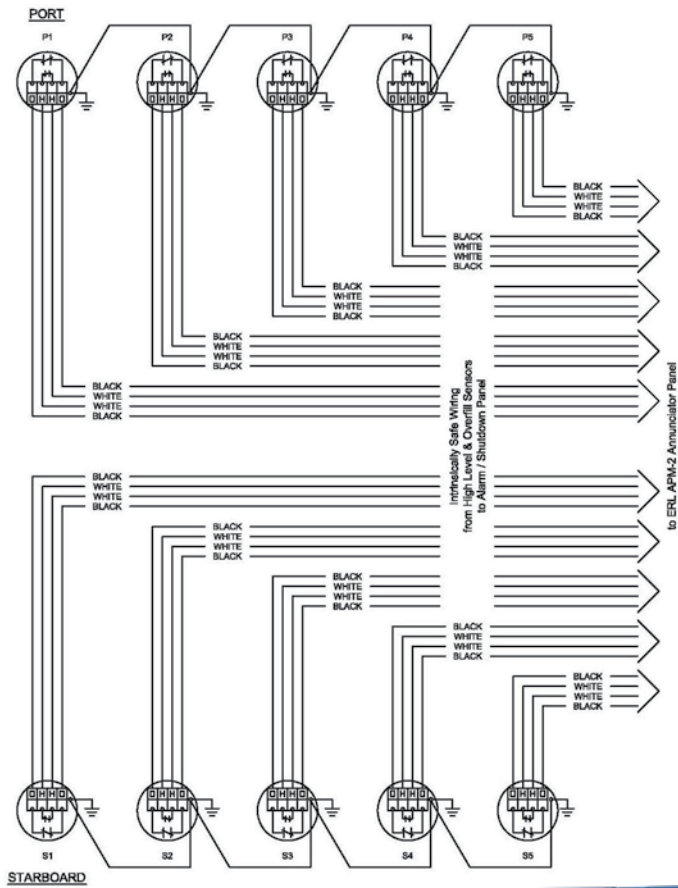
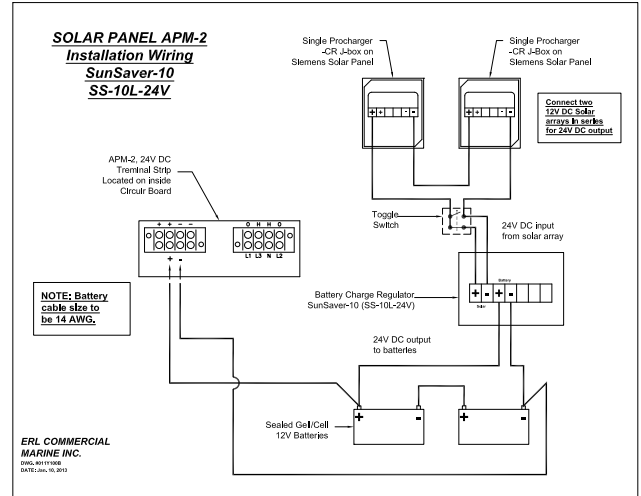

## APM-2F FIXED ALARM PANEL

- **FULL REGULATORY COMPLIANCE**

ERL's APM-2F vessel mounted High Level/Overfill Alarm Annunciator Panel satisfies 46 CFR 39.20 9 (a) when connected to an ERL Liquid Level Sensor System. The installation must conform to 46 CFR 111.105 and API Recommended Practice 1125. The APM-2F Alarm Panel is U.S. Coast Guard accepted and satisfies OPA-90 requirements for overfill protection devices and is suitable for ABS classed vessels.

- **QUALITY CONSTRUCTION**

The APM-2F's weatherproof cabinet is 100% heavy gauge stainless steel. All electrical components are UL, FM and CSA approved. Each APM-2F Alarm Panel undergoes complete operational testing and final inspection before shipment.

- **SAFE AND RELIABLE OPERATION**

An amber light is used to represent a high level alarm and red lights annunciate an overfill warning. Additionally, an alternating 105 decibel tone indicates a high level alarm while a steady 105 decibel tone signal indicates an overfill warning. The audible signals can be easily heard from any location on the deck.

- **COST EFFECTIVE**

APM-2F is a cost effective option to APM-2 to provide fixed mounted barge high level and overfill occurrence notifications when there is not a need to have individual tank identification.

- **SOLAR POWERED**

APM-2F comes with a solar panel charging to maintain battery power.

- **ALARM PANEL BYPASS**

The panel comes with a Bypass switch if there is a need to bypass the panel.

- **TANDEM LOADING**

An optional single/tandem loading switch is available to allow for Tandem Loading Capability.

- **LOW BATTERY POWER WARNING**

The panel is equipped with a low battery warning light and cycles the alarm horn which requires a manual reset to clear.

- **COMPLETE PACKAGE**

APM-2F comes with solar panel mounted directly to the cabinet. All that is needed is to mount the cabinet and connect power to the remote battery box.





APM-2F WIRING DIAGRAM

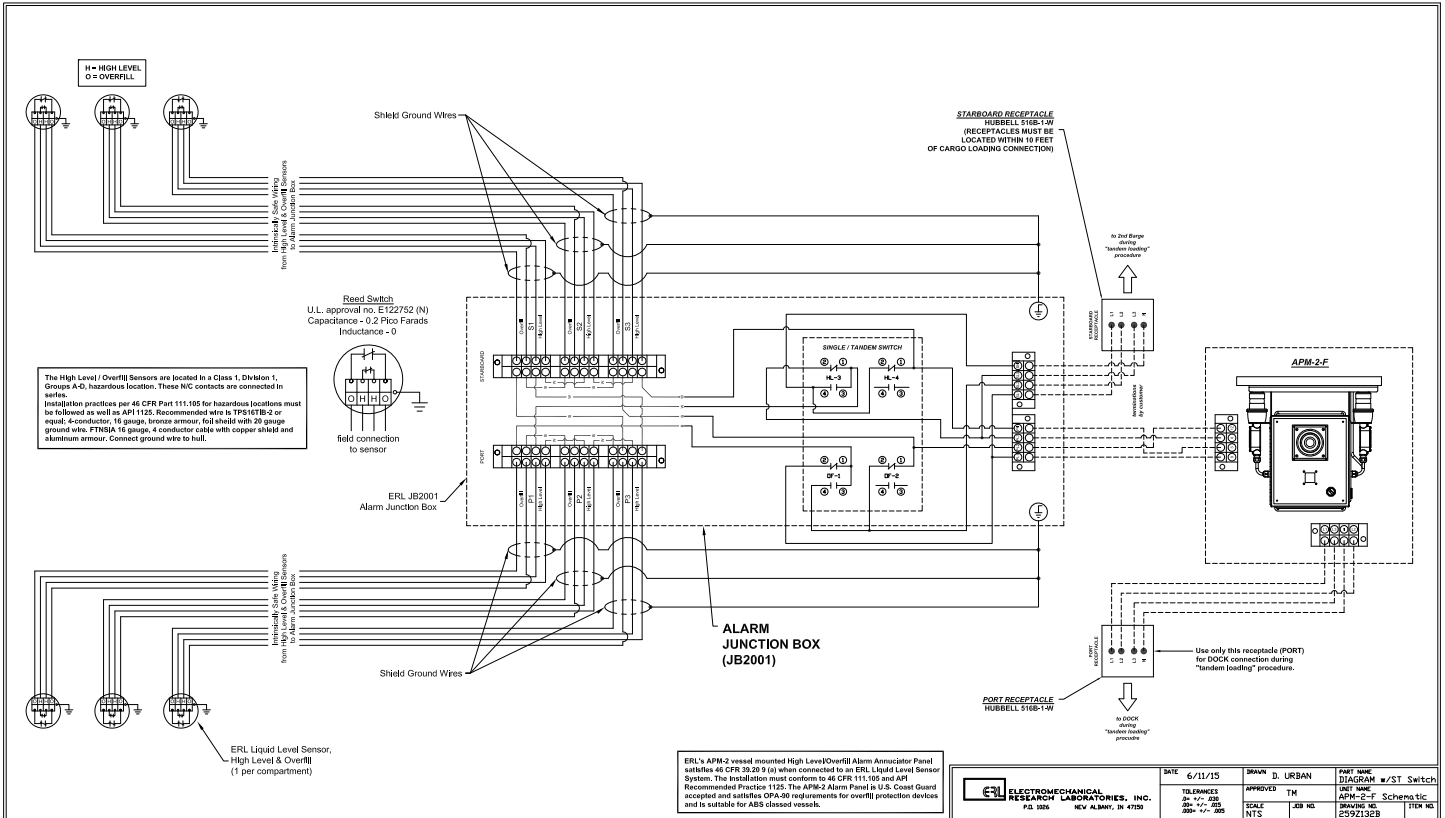

ERL's APM-2 vessel mounted High Level/Overfill Alarm Annunciator Panel satisfies 46 CFR 39.20.9 (a) when connected to an ERL Liquid Level Sensor System. The installation must conform to 46 CFR 111.105 and AHJ Recommended Practice 1125. The APM-2 Alarm Panel is U.S. Coast Guard accepted and satisfies OPA-90 requirements for overfill protection devices and is suitable for ABS classed vessels.

	ELECTROMECHANICAL RESEARCH LABORATORIES, INC. P.O. BOX NEW ALBANY, IN 47150	DATE	6/11/15	DRAWN	D. URBAN	PART NAME	DIAGRAM w/ST Switch
		TOLERANCES	AS SHOWN 20-+/- .05 300-+/- .005	APPROVED	T.M.	USE NAME	APM-2-F Schema.tic
		SCALE	NTS	JOB NO.		DRAWING NO.	2592132B
						REVISION	REVISION

## APM-2F-APA ANTI POLLUTION ALARM

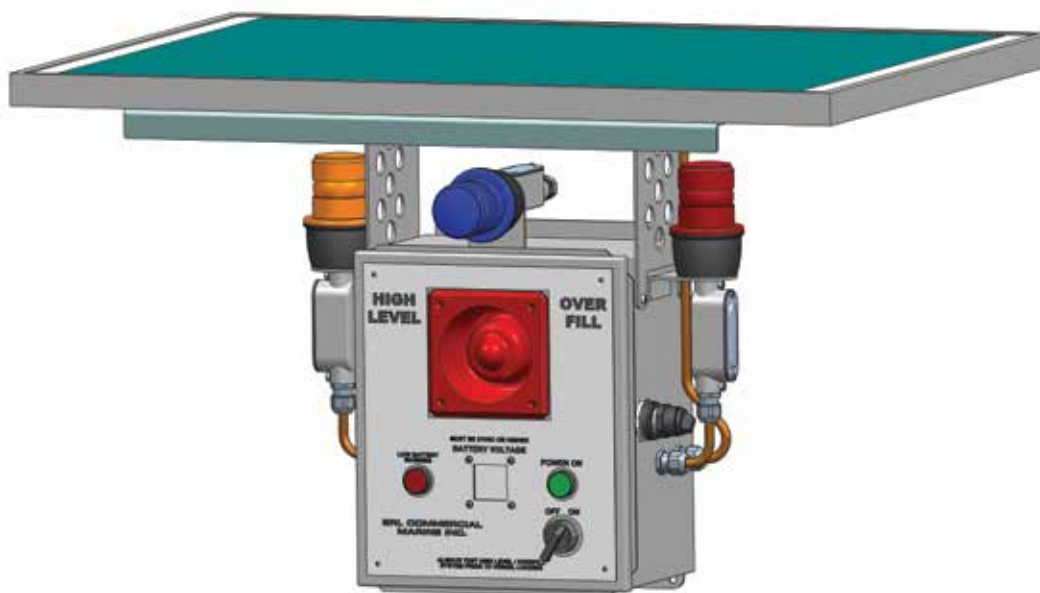

- **FULL REGULATORY COMPLIANCE**

ERL's APM-2 vessel mounted High Level/Overfill Alarm Annunciator Panel satisfies 46 CFR 39.20 9 (a) when connected to an ERL Liquid Level Sensor System. The installation must conform to 46 CFR 111.105 and API Recommended Practice 1125. The APM-2 Alarm Panel is U.S. Coast Guard accepted and satisfies OPA-90 requirements for overfill protection devices and is suitable for ABS classed vessels.

- **QUALITY CONSTRUCTION**

The APM-2's weatherproof cabinet is 100% heavy gauge stainless steel. All electrical components are UL, FM and CSA approved. Each APM-2 Alarm Panel undergoes complete operational testing and final inspection before shipment.

- **CARGO LEVEL ALARM**

The APM-2F contains an audio and visual notification for an occurrence of high level and overfill alarms mounted in the cargo tanks.

- **ANTI-POLLUTION ALARM**

The APA is an intrinsically safe, Class I Div I, float operated switch mounted in the pollution head cavity of the barge cargo pump. The alarm provides notification in the event of a pump seal failure during transfer.



## APM-2F-APA ANTI POLLUTION ALARM

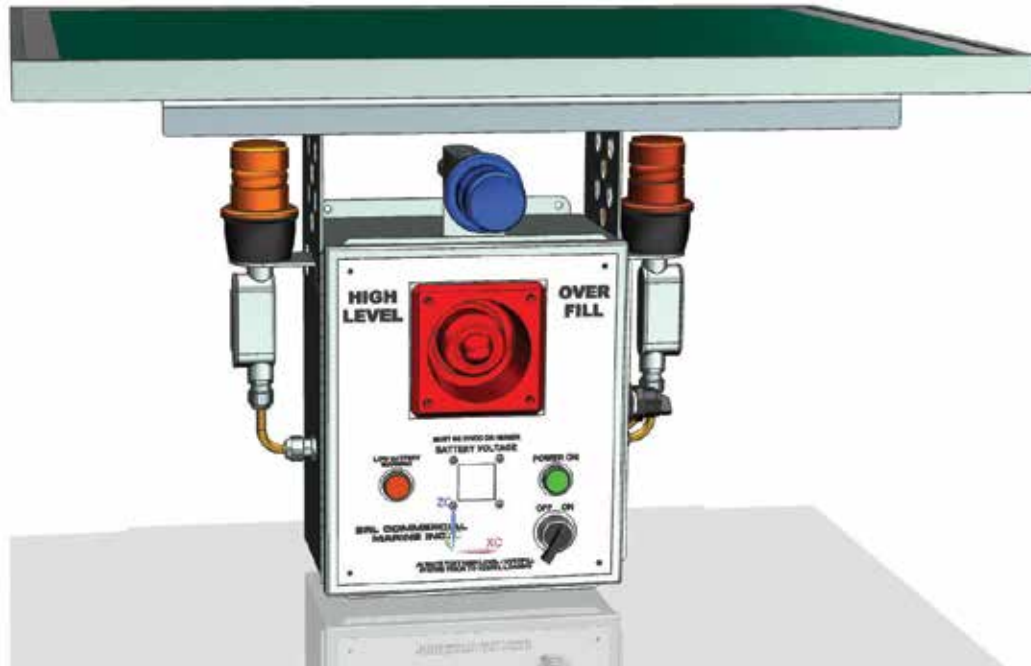

- **SAFE AND RELIABLE OPERATION**

The annunciator lights on the APM-2 Alarm Panel are displayed in the same layout configuration as the barge's cargo compartments for quick and easy recognition. Amber lights are used to represent a high level alarm and red lights announce an overfill warning. Additionally, an alternating 105 decibel tone indicates a high level alarm while a steady 105 decibel tone signal indicates an overfill warning. The audible signals can be easily heard from any location on the deck.

- **SOLAR POWERED**

APM-2F comes with optional solar panel charging to maintain battery power.

- **ALARM PANEL BYPASS**

The panel comes with a Bypass switch if there is a need to bypass the panel.

- **TANDEM LOADING**

An optional single/tandem loading switch is available to allow for Tandem Loading Capability.

- **LOW BATTERY POWER WARNING**

The panel is equipped with a low battery warning light and cycles the alarm horn which requires a manual reset to clear.



## APM-2F-APA BARGE WIRING DIAGRAM

The High Level / Overfill Sensors are located in a Class 1, Division 1, Groups A-D, hazardous location. These N/C contacts are connected in series.  
 Installation practices per 46 CFR Part 111.105 for hazardous locations must be followed as well as API 1125. Recommended wire is TPS161TB-2 or equal; 4-conductor, 16 gauge, bronze armour, foil shield with 20 gauge ground wire, FTNSA 16 gauge, 4 conductor cable with copper shield and aluminum armour. Connect ground wire to hull.

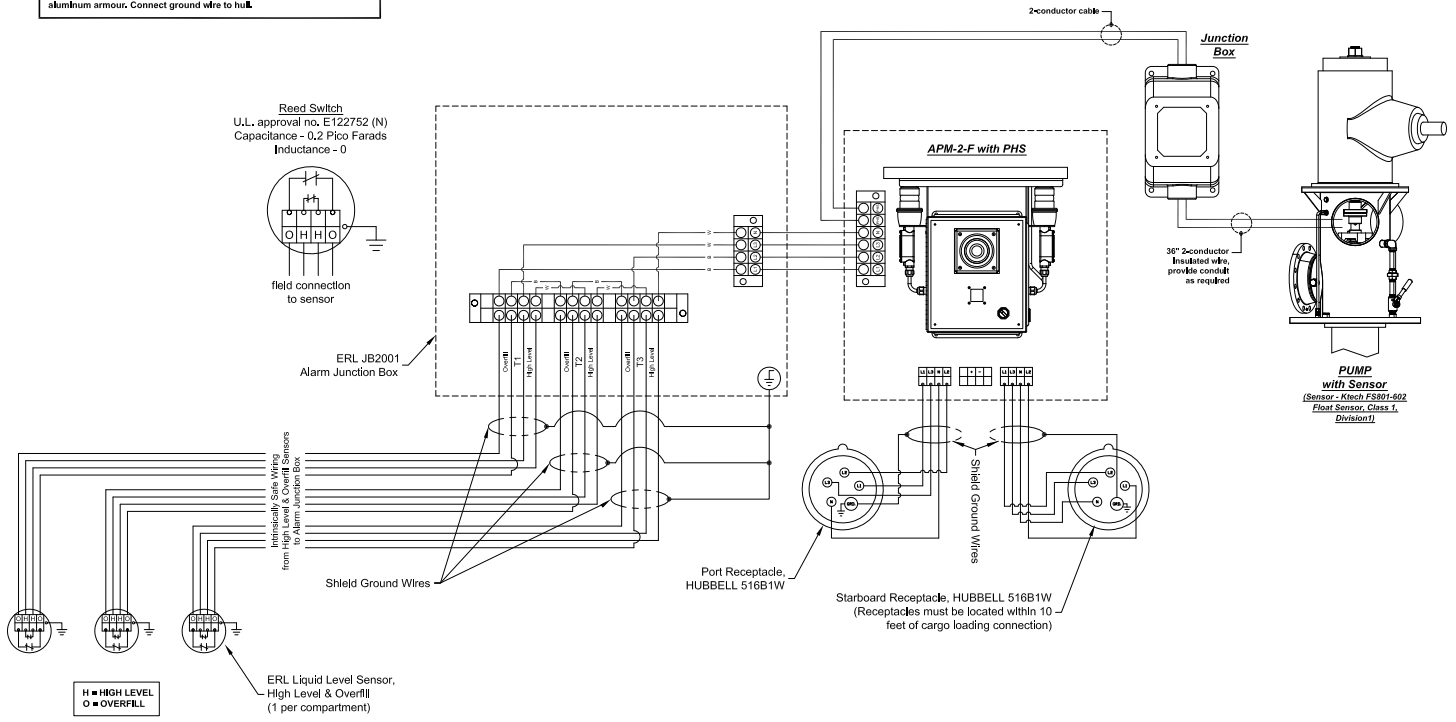

ERL's APM-2 vessel mounted High Level/Overfill Alarm Annunciator Panel satisfies 46 CFR 39.20 9 (a) when connected to an ERL Liquid Level Sensor System. The installation must conform to 46 CFR 111.105 and API Recommended Practice 1125. The APM-2 Alarm Panel is U.S. Coast Guard accepted and satisfies OPA-90 requirements for overfill protection devices and is suitable for ABS classed vessels.



## APM-2E FIXED ALARM PANEL

- **FULL REGULATORY COMPLIANCE**

ERL's APM-2E vessel mounted High Level/Overfill Alarm Annunciator Panel satisfies 46 CFR 39.20 9 (a) when connected to an ERL Liquid Level Sensor System. The installation must conform to 46 CFR 111.105 and API Recommended Practice 1125. The APM-2E Alarm Panel is U.S. Coast Guard accepted and satisfies OPA-90 requirements for overfill protection devices and is suitable for ABS classed vessels.



- **QUALITY CONSTRUCTION**

The APM-2E's weatherproof cabinet is 100% heavy gauge stainless steel. All electrical components are UL, FM and CSA approved. Each APM-2E Alarm Panel undergoes complete operational testing and final inspection before shipment.

- **SAFE AND RELIABLE OPERATION**

An amber light is used to represent a high level alarm and red lights annunciate an overfill warning. Additionally, an alternating 105 decibel tone indicates a high level alarm while a steady 105 decibel tone signal indicates an overfill warning. The audible signals can be easily heard from any location on the deck.

- **COST EFFECTIVE**

APM-2E is a cost effective option to APM-2 to provide fixed mounted barge high level and overfill occurrence notifications when there is not a need to have individual tank identification.

- **SOLAR POWERED**

APM-2E comes with a solar panel charging to maintain battery power.

- **ALARM PANEL BYPASS**

The panel comes with a Bypass switch if there is a need to bypass the panel.

- **TANDEM LOADING**

An optional single/tandem loading switch is available to allow for Tandem Loading Capability.

- **LOW BATTERY POWER WARNING**

The panel is equipped with a low battery warning light and cycles the alarm horn which requires a manual reset to clear.

- **COMPLETE PACKAGE**

APM-2E comes with solar panel mounted directly to the cabinet. All that is needed is to mount the cabinet and connect power to the remote battery box.

## APM-3



- **PORTABLE AND COMPLETELY SELF CONTAINED**  
ERL's APM-3 is very portable, weighing 8 lbs. The unit is battery powered with a self-contained panel and the handle makes for easy portability.
- **SELF RELIABLE OPERATION**  
The APM-3 is housed in a weather proof enclosure rated for outdoor use. The output of the APM-3 is intrinsically safe for connection in Class I, II, and III, Division 1 and 2, Groups A-G Hazardous Locations.
- **EASY TO OPERATE**  
With a long cable attached to a Hubbell 516C-1W receptacle, the APM-3 allows for easy connection to the vessel liquid level sensor system with the panel positioned outside for the hazardous area. Indicator lights and an audible alarm warns the tankerman of a high level/overfill condition over the entire barge. Powered by 9V batteries.





## SUPERACT™ 12" ROUND MARINE SAFETY RELIEF VALVE



U.S. Patents  
5,205,311 &  
5,158,104

- **AUTOMATIC OPERATION**

The Superac 12" round Marine Safety Relief Valve (Spill Valve) is designed to operate automatically with a set point repeatability of 3%. This valve was designed and built to withstand the most severe marine service and cargos. Should an overflow or over pressurization occur, this valve will automatically open sufficiently to relieve cargo at a flow rate equal to the overflow rate. This will maintain safe working pressure within the cargo compartment being protected. When the overflow condition abates, the valve will automatically close and reseal. In addition to overflow protection, this valve also protects the cargo compartment from over pressurization which can occur if the vent header piping becomes blocked or if a P-V Valve does not open.

- **SIMPLE WEIGHT OPERATED DESIGN**

Our exclusive weight operated design with nonlinear closure force affords increased flow rates at reduced pressure drops. This valve has very few parts and virtually no maintenance requirements except for the resilient vapor seal.

- **EASILY FIELD TESTED**

Checking the valve prior to each loading could not be easier. Simply lift the Test Handle to verify that the valve is working and/or is not stuck. ERL's exclusive set point test feature also allows you to verify set opening point at the valve on deck in less than one minute.

- **VAPOR TIGHT SEAL**

ERL's resilient seal and Teflon™ seal shield are field proven to seal very well and provide extended service life.

- **100% STAINLESS STEEL CONSTRUCTION**

All components are 300 series stainless steel except for the elastomer seal and the seal shield for extended service life with little need for maintenance.

- **CERTIFIED TO MEET OR EXCEED ALL USCG REQUIREMENTS**

Every Superac Safety Relief Valve is 100% factory tested prior to shipment. The Superac 12" Round Marine Safety Relief Valve is certified to meet or exceed all USCG and ASTM F-1271 test requirements.

**SECTION  
03**

**VENTING PRODUCTS**



**SUPERAC™ PV - 6 II High Velocity P-V Valve**

**pg 79**



**Equate™ 2.5", 4" and 8" P-V Valves**

**pg 88**



**Flame Screens**

**pg 100**



**Protected Flame Screen Vent**

**pg 101**



**Vent Stacks**

**pg 102**



Superac 6" stainless steel High Velocity PV valve Model II - mounted on collapsible piping.



Superac 6" High Velocity PV valve Model II - Mounted on collapsible piping next to Emergency Shutdown (EMS-001) sign with stainless steel frame (EMF-001).



2.5" Equate PV Valve mounted on stand pipe next to 2" Sampling Ball Valve.



Typical Vapor Headers with ERL Vent Header Sight Glass and ERL Model 505 Pressure/Vacuum Gauge.



8" Equate PV Valve mounted on Vapor head pipe.



4" Equate Valve



## EXCERPTS FROM FEDERAL REGISTER

PART 11 - Dept. of Transportation - Coast Guard - June 21,1990

46CFR Part 39 Vapor Control Systems

Subpart 39.20 Design and Equipment

39.20-11 Vapor overpressure and vacuum protection -TB/ALL (continued)

**The following section, reprinted here for your convenience, contains the USCG rules and regulations pressure/vacuum venting systems.**

### VENTING PROTECTION

39.20-11 Vapor overpressure and vacuum protection- TB/All

- (a) The cargo tank venting system required by 32.55 of this chapter must:
- (1) Be capable of discharging cargo vapor at 1.25 times the maximum transfer rate such that the pressure in the vapor space of each tank connected to the vapor collection system does not exceed:
    - (i) The maximum design working pressure for the tank, or (ii) If a spill valve or rupture disk is fitted, the pressure at which the device operates;
  - (2) Not relieve at a pressure corresponding to a pressure in the cargo tank vapor space of less than 1.0 psig;
  - (3) Prevent a vacuum in the cargo tank vapor space, whether generated by withdrawal of cargo or vapor at maximum rates, that exceeds the maximum design vacuum for any tank connected to the vapor collection system; and
  - (4) Not relieve at a vacuum corresponding to a vacuum in the cargo tank vapor space of less than 0.5 psi below atmospheric pressure.
- (b) Each pressure-vacuum relief valve must:
- (1) Be tested for venting capacity in accordance with paragraph 1.5.1.3 of API 2000; and
  - (2) Have a means to check that the device operates freely and does not remain in the open position, if installed after July 23, 1991.
- (c) The relieving capacity test required by paragraph (b)(1) of this section must be carried out with a flame screen fitted at the vacuum relief opening and at the discharge opening if the pressure-vacuum relief valve is not designed to ensure a minimum vapor discharge velocity of 30 meters (98.4 ft.) per second.



## HIGH VELOCITY PRESSURE/VACUUM RELIEF VALVE AUTOMATIC OPERATION



**SUPERAC™  
MODEL PV-6 II**

**U.S. COAST GUARD  
APPROVED**

**U.S. Patent  
5,960,823**

- **QUIET, AUTOMATIC OPERATION**

The PV-6 II valve has all of the proven design characteristics that have made the original PV-6 valve so reliable. In addition to quiet automatic operation, the vacuum side of the PV-6 II valve has 30% fewer parts, increase flow rate and a 16% angled housing to allow positive drainage of any cargo condensation.

- **SIMPLE WEIGHT OPERATED DESIGN**

Our weight operated design doesn't suffer from the performance variations caused by spring deterioration or the increased friction between internal guide stems and bushings common with friction-type designs. All operating mechanisms are located outside of the vapor stream eliminates the possibility of valve sticking due to product or contaminant build-up. Also the vacuum side of the valve is angled for positive drainage of cargo condensation back into the vapor header.

- **SET POINT REPEATABILITY 3%**

Unique low friction design utilizes sealed stainless steel roller bearings outside of the vapor exhaust stream allowing the valve to open repeatedly within 3% of factory stated set opening point. Two easily reached test handles, as required by law, allow for easy testing.

- **100% STAINLESS STEEL**

The main valve body is made of 1/2" thick stainless steel, with 1/4" pipe. Even the bearings and the full weather covers are stainless steel.

- **HIGH VELOCITY DISCHARGE**

The minimum discharge velocity rate of 40 meters/second is achieved at even the lowest flow rates. The unique pressure focusing nozzle creates a columnar exhaust flow path allowing vapors to disburse well above the deck level.

## DESCRIPTION OF THE PV-6 II

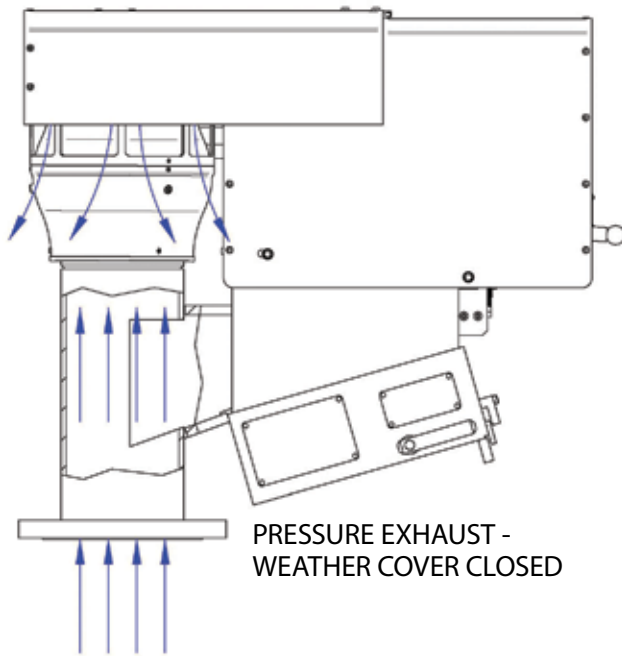

PRESSURE EXHAUST -  
WEATHER COVER CLOSED

The ERL Superac 6" High Velocity weight operated P-V Valves operates automatically on both the High Velocity pressure side and the vacuum side of each valve. All of the operating mechanisms are located outside of the vapor exhaust stream. This is critically important since it eliminates valve sticking due to contaminant build up between shafts and bushings. The Superac design uses sealed stainless steel bearings at all pivot points, which greatly improves valve set point accuracy. This design creates a valve, which is repeatable to 3% of set opening point and has a total pressure increase of less than 10% from initial opening to the full open flow rate exceeding 18,000 barrels per hour on the pressure side. The weather cover can be either closed or open during operation. With this

cover closed, the pressure side of the valve exhausts through a radial 30 x 30 mesh stainless steel flame screen. The portion of the cover over the vertical discharge section of the valve is hinged so that it may be opened to allow the high velocity flow to travel straight up in order to effectively get the vapors out of the deck working environment.

The focusing nozzle that directs this flow upward is similar in construction to a high velocity hose nozzle in that it incorporates both an inner cone and an outer focusing shell. This construction results in superior performance.

The outer shell and weather cover prevent the possibility of snow and ice buildup at the discharge nozzle.

The pressure sides of both valves achieve a minimum discharge velocity of 40 meters per second even at the lowest flow rates. This number is obtained due to the fine finish of the inner cone, smooth air flow path provided in the nozzle orifice and the accurately controlled weight operated opening mechanism. A damper is provided to prevent valve oscillations or chatter on both the pressure and vacuum sides of both P-V Valves.

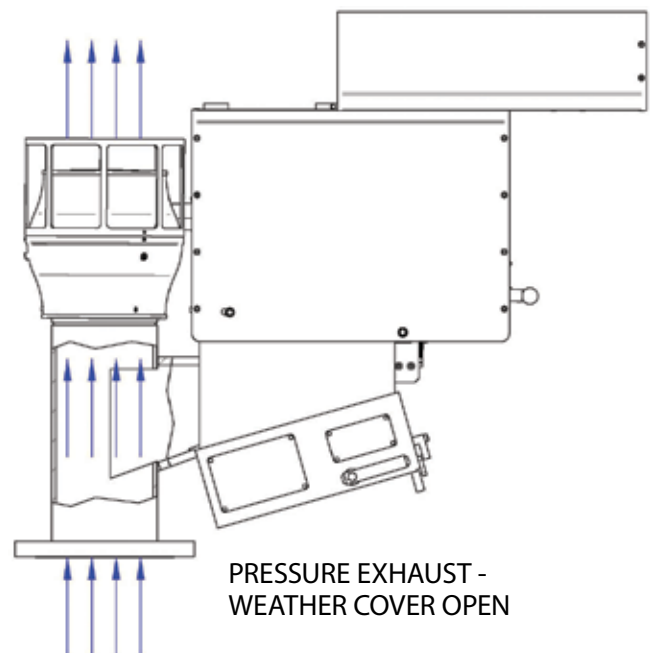

PRESSURE EXHAUST -  
WEATHER COVER OPEN



## DESCRIPTION OF THE PV-6 II

The vacuum sides of both valves use a Teflon-faced stainless steel seal plate closing against a machined stainless steel opening. This weight operated mechanism uses a pivoting arm rather than a vertically sliding shaft to reduce friction and improve set point accuracy. This design approach yields repeatability of 3% of set point opening pressure. A drawer style flame screen of 30 x 30 mesh is fitted to the vacuum inlet allowing rapid cleaning and service.

Valve operation is fully automatic and totally weight operated preventing changes in performance over time due to spring deterioration or increased friction within the valve.

Although the operating principal for the vacuum side of each valve is similar, the PV-6 II has 30% fewer parts, an increased vacuum flow rate and a 16% angled housing to insure positive drainage of any cargo condensation.

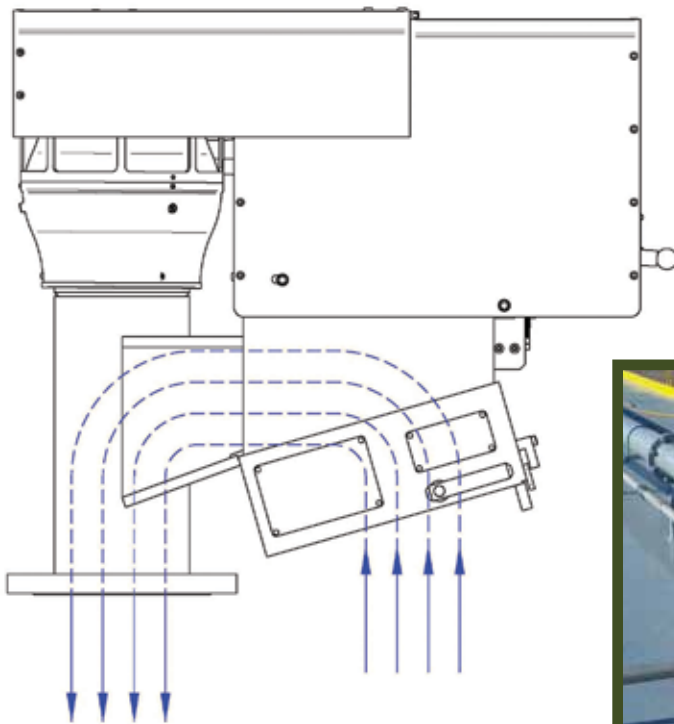

Both the pressure and vacuum sides of the valve are equipped with test handles which allow the operator to easily open the valve for testing.



Superac 6" stainless steel High Velocity PV valve Model II shown on 8" vent header.



## OPERATION OF THE ERL PV-6 II OPERATING PRINCIPLE

The term, P-V VALVE is short for Pressure and Vacuum Relief Valve. As the name implies, the P-V Valve is a dual function valve. Mounted on a liquid cargo vessel, this valve opens at a specific design set point to relieve vessel tank pressure to the atmosphere. Also, in the event the liquid cargo vessel experiences a negative pressure, or vacuum, the vacuum side of the valve opens at a specific design set point permitting outside air to enter the vessel. Simply stated, the P-V Valve allows a liquid cargo vessel to breath in and out within specific design vacuum and pressure levels.

The Superac™ P-V Valve Model I and Model II are both weight operated on both the pressure and vacuum sides of the valve. This means that on both sides of the valve there is a round opening, each sealed by a weight. The area of each opening in square inches is calculated as  $\pi \times r^2$  or  $3.141 \times r^2$ . The area and the sealing weight over this area directly relate to the pressure at which the valve opens. The formula for calculating set opening point of a weight operated valve is:

$$\text{SET POINT} = \frac{\text{WEIGHT}}{3.141 \times \text{RADIUS SQUARED}}$$

For example:  

$$1 \text{ PSI SET POINT} = \frac{28.27 \text{ lbs.}}{3.141 \times 3 \text{ SQUARED}}$$

This formula is the same for all weight operated valve designs and works on both the pressure and vacuum side of the valve. The illustration to the left will help illustrate the principle of our weight operated valve.

PV Valves are mechanical devices and they operate in a vaporous environment, often laden with rust particles. Friction within the PV Valve is a concern, because set opening points can increase directly as friction increases. Therefore the adjusted set point formula below includes friction to more closely reflect actual conditions.

$$\text{SET POINT} = \frac{\text{WEIGHT} + \text{FRICTION}}{3.141 \times \text{RADIUS SQUARED}}$$

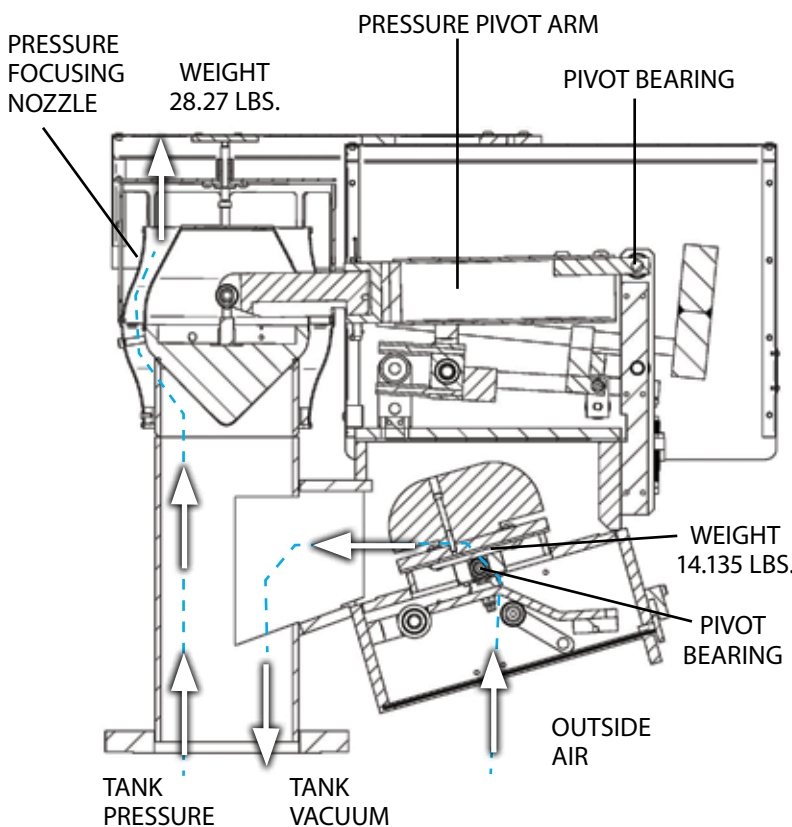

The ERL PV Valve virtually eliminates friction by eliminating sliding shafts and bushings within the valve. By using sealed stainless steel roller bearings and pivot arms outside of the vapor stream, valve reliability and set point accuracy are greatly increased.

The term, High Velocity, pertains only to the pressure side of the ERL P-V valve. This term applies to a discharge velocity greater than 30 meters/second. Discharge velocities greater than 30 meters/second are needed to prevent flame propagation into the barge. Per USCG regulations the vacuum side of the valve is protected by a 30 x30 mesh stainless steel flame screen.



## TESTING OF THE ERL PV-6 II

Per 46 CFR 39.20-11 (b)2 the ERL Superac™ High Velocity P-V Valve has the mechanical means to check both the pressure and vacuum sides of the valve to verify that they open freely. Each test lever is well identified and this test is simply performed as described in the illustration below. When testing the pressure side of the valve it does not matter if the weather cover is open or closed. During testing or normal operation, cargo vapors may be exhausted. Extreme caution should be exercised as these vapors may be harmful to personnel.

On barge pressure testing or bench testing of both pressure and vacuum valve functions can be performed by personnel trained to perform such tests. In the case of on-barge testing extreme caution should be used to avoid overpressurizing the barge. The test levers on both pressure and vacuum sides of the valve should be operated to verify the valve operates freely prior to each vessel loading.

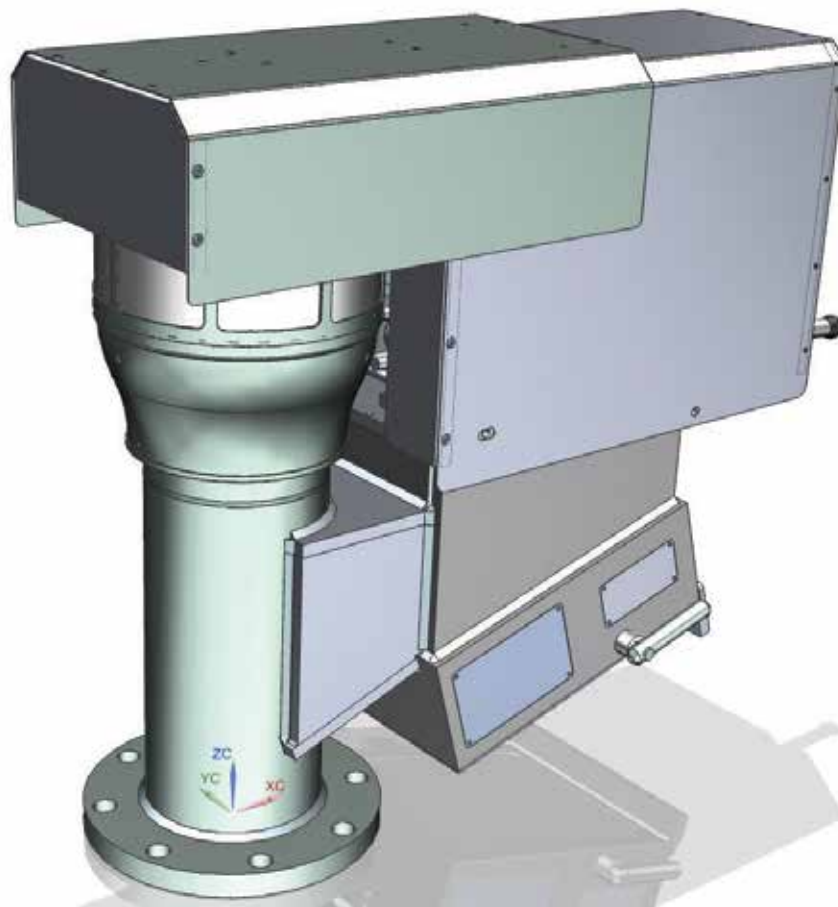



## **SUPERAC™ MODEL PV-6 II PRESSURE FLOW CURVES DATA BASED ON AIRFLOW**

LATEST FLOW CURVES AVAILABLE ONLINE AT [WWW.ERLMARINE.COM](http://WWW.ERLMARINE.COM)

### **VACUUM CURVES:**

.5 PSI VACUUM  
.75 PSI VACUUM  
1.0 PSI VACUUM  
1.5 PSI VACUUM  
2.0 PSI VACUUM  
3.0 PSI VACUUM

### **PRESSURE CURVES:**

1.0 PSI PRESSURE  
1.2 PSI PRESSURE  
1.4 PSI PRESSURE  
1.5 PSI PRESSURE  
1.6 PSI PRESSURE  
1.75 PSI PRESSURE  
2.0 PSI PRESSURE  
2.2 PSI PRESSURE  
2.4 PSI PRESSURE  
2.5 PSI PRESSURE  
2.6 PSI PRESSURE  
2.8 PSI PRESSURE  
3.0 PSI PRESSURE  
3.5 PSI PRESSURE  
5.0 PSI PRESSURE  
5.5 PSI PRESSURE  
6.0 PSI PRESSURE



### SUPERAC™ MODEL PV-6II

Model PV-6 II with  
weather cover closed.



Model PV-6 II with  
weather cover open.

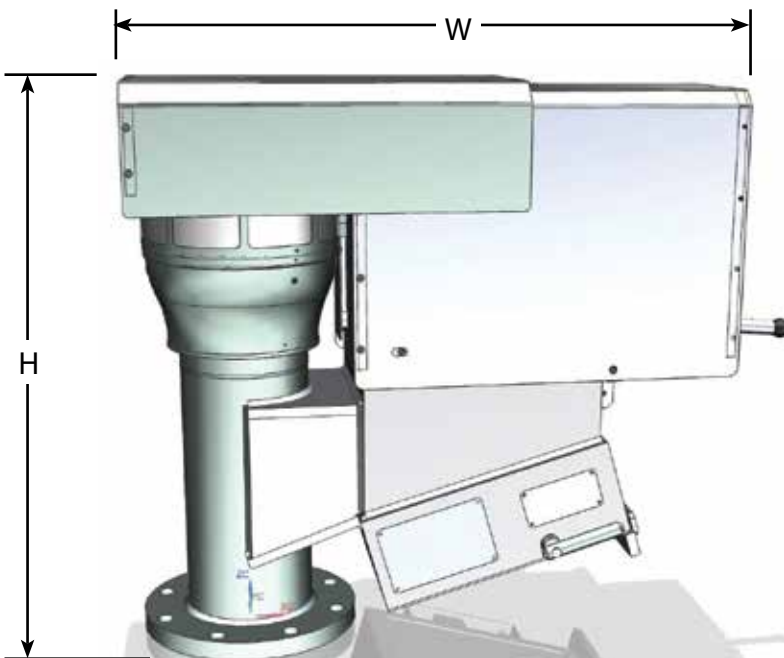

H = 28.2"  
W = 33.3"  
D = 14.3"  
List Weight:  
350 lbs

## PV-6 II PERFORMANCE



Superac 6" High Velocity PV Valve Model II mounted on collapsible vapor pipe.

**NOTE:** The velocity of the PV-6 discharge is measured with a precision hot wire anemometer at the valve seat. The minimum recorded velocity of the PV-6 is 40 meters/second. At flow volumes exceeding 150 cubic feet/minute the PV-6's flow velocity is in excess of 50 meters/second, which is at the upper limit indicated by the instrument (hot wire anemometer) used for velocity discharge testing.



### PV-6 II - PERFORMANCE

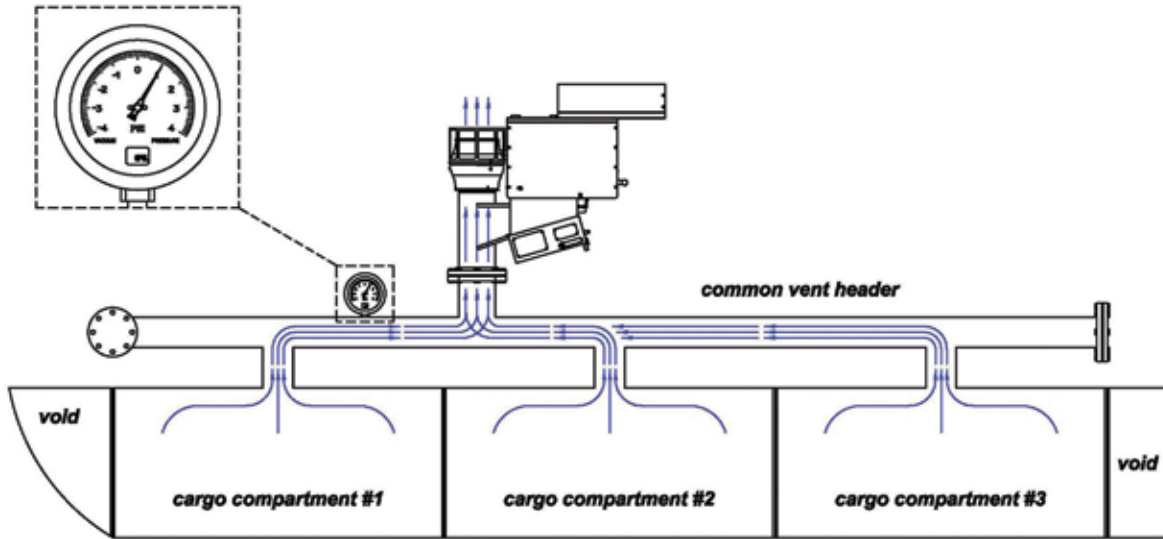

*Flow Schematic During Pressure Build-up Situation*

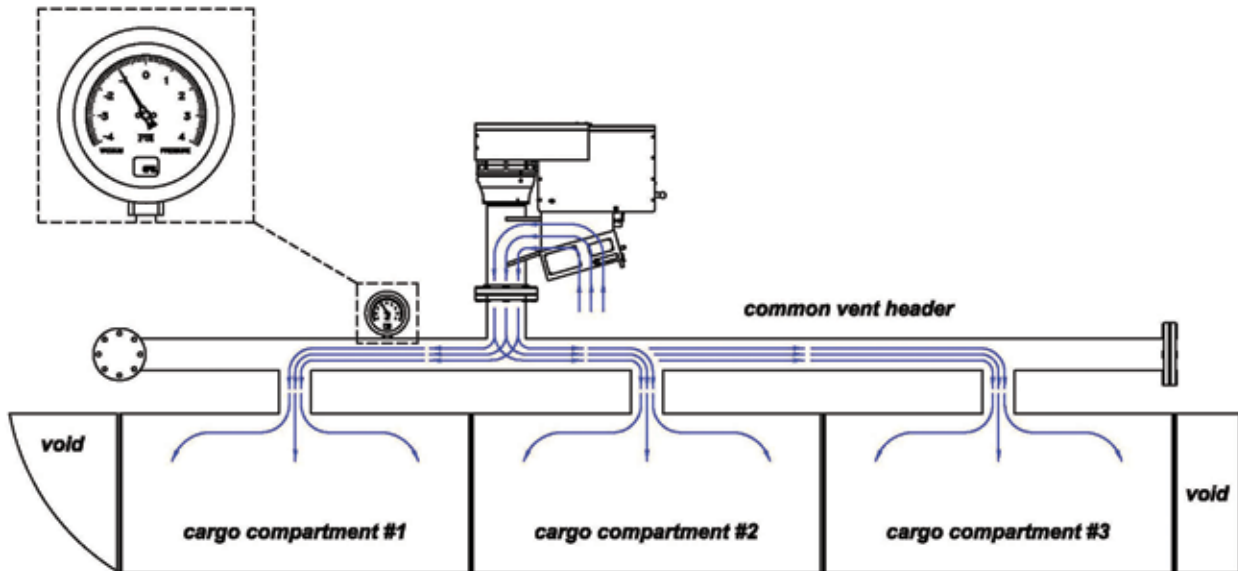

*Flow Schematic During Vacuum Build-up Situation*

## EQUATE™ SERIES PRESSURE/VACUUM RELIEF VALVE EQUATE™ PV-2.5

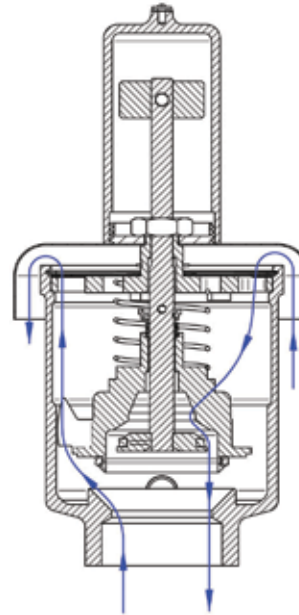

- **AUTOMATIC OPERATION**

The Equate PV-2.5, 2.5" P-V Valve is designed to automatically maintain safe design working pressure and vacuum levels within your barge. Your barge remains closed vapor tight until set point pressure or vacuum overcomes the force of each respective set point spring, allowing vapor flow out or air flow in, at a rate sufficient to maintain safe levels within your barge.

- **SIMPLER DESIGN**

Having very few parts, the Equate P-V valve is spring operated with one spring to determine the pressure set opening point and the second spring to determine the vacuum set opening point. A manual test handle allows the tankerman to check operation of both the pressure and vacuum sides of the valve. Both the test handle and valve weather covers are easily removed allowing complete valve inspection in minutes. Easy to replace elastomer seals, one pressure and one vacuum seal, insure vapor tightness.

- **100% STAINLESS STEEL**

All components are 300 series stainless steel for extended service life and reduce need for maintenance. The resilient pressure and vacuum seals are the only parts that are not stainless steel.

- **CERTIFIED TO MEET ALL USCG REQUIREMENTS**

Every Equate P-V Valve is 100% factory tested prior to shipment and is USCG Approved.

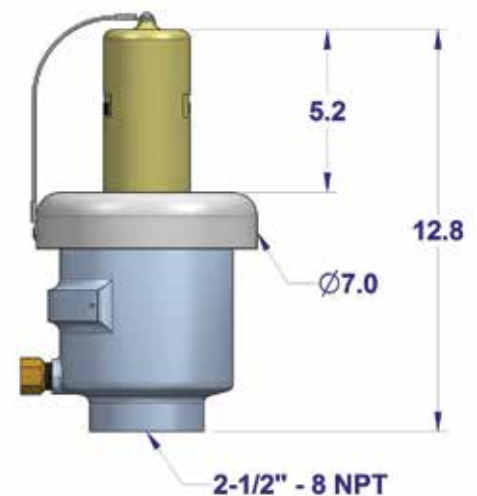



## **EQUATE™ SERIES 2.5" PV VALVE PRESSURE FLOW CURVES DATA BASED ON AIRFLOW**

LATEST FLOW CURVES AVAILABLE ONLINE AT [WWW.ERLMARINE.COM](http://WWW.ERLMARINE.COM)

**VACUUM CURVES:**

.5 PSI VACUUM  
1.0 PSI VACUUM  
1.5 PSI VACUUM

**PRESSURE CURVES:**

1.0 PSI PRESSURE  
1.5 PSI PRESSURE  
2.0 PSI PRESSURE  
2.2 PSI PRESSURE  
3.0 PSI PRESSURE



## EQUATE™ SERIES 2.5" PV VALVE VACUUM FLOW CURVE DATA BASED ON AIRFLOW

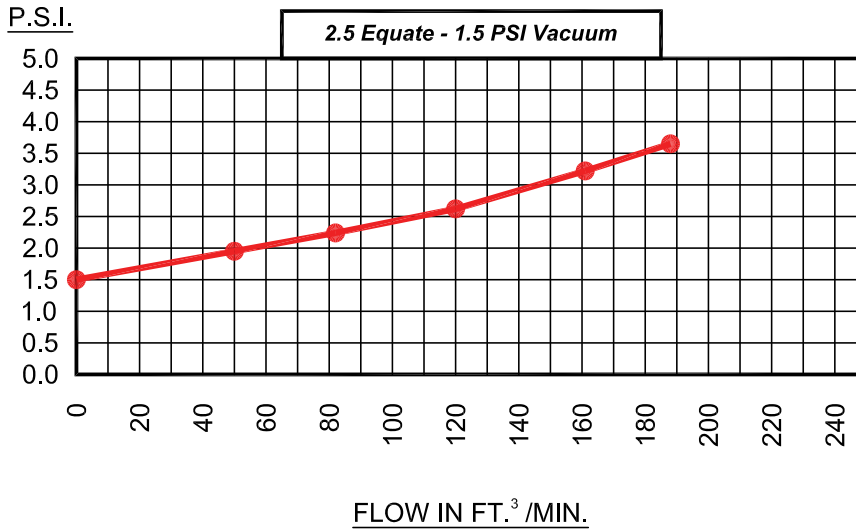

BARRELS PER HOUR	FLOW FT. <sup>3</sup> per MIN.	P.S.I.
------------------	--------------------------------	--------

535	50	1.95
877	82	2.24
1284	120	2.62
1723	161	3.22
2012	188	3.65

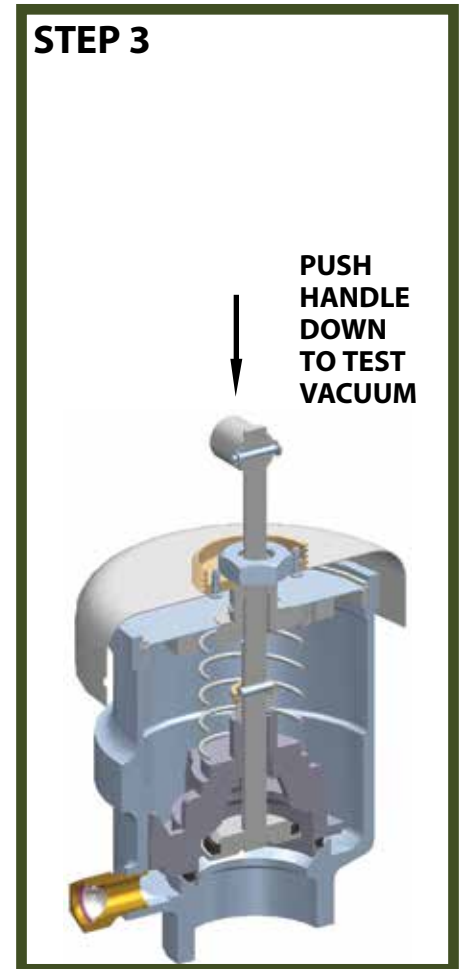
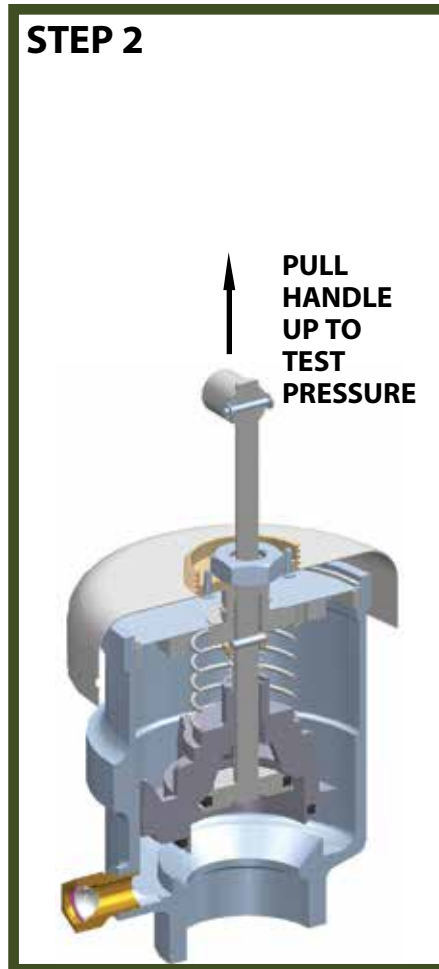
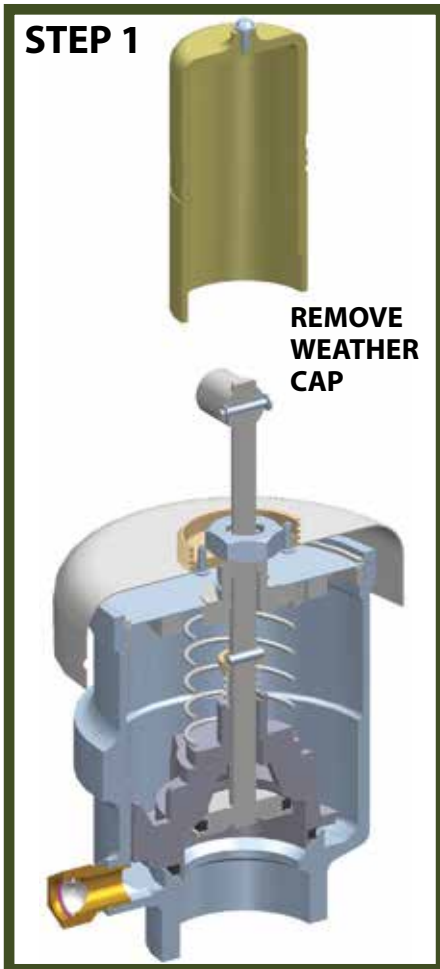



**EQUATE™ SERIES 2.5" PV VALVE**

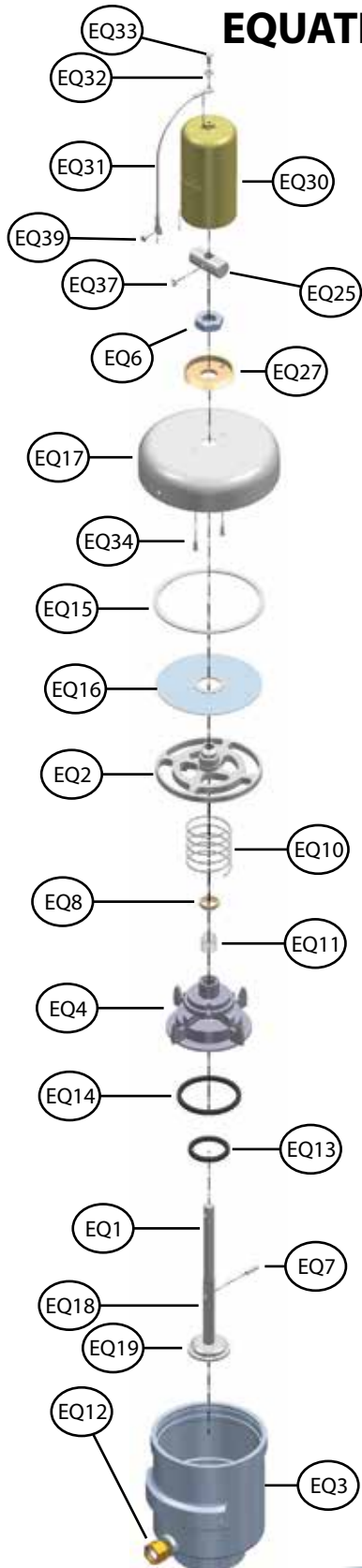

Item	Part Name	Qty.
EQ1	Stem, weldment	1
EQ2	Top Retainer	1
EQ3	Main Body	1
EQ4	Follower	1
EQ6	Hex Jam Nut, 3/4-16	1
EQ7	Dowel Pin, 3/16 x 3/4	1
EQ8A	Spring Retainer	1
EQ9	Ext. Retaining Ring, 1"	1
EQ10	Spring, pressure	
EQ11	Spring, vacuum	
EQ12	Drain Plug	
EQ13	Quadring, vacuum	1
EQ14	Quadring, pressure	1
EQ15	Spiral Retn. Ring	1
EQ16	Flame Screen	1
EQ17	Cover	1
EQ18	Stem	1
EQ19	Seal Holder	1
EQ20	Follower (casting)	1
EQ21	Main Body (casting)	1
EQ22	Top Retainer (casting)	1
EQ23	Internal Retaining Ring, 3/4"	1
EQ24	Plug Screen	1
EQ25	Test Knob	1
EQ26	Clevis Pin w/EQ37, 3/16 x 1	1
EQ27	Threaded Bushing	1
EQ30	Knob Cover	1
EQ31	Lanyard (same as D10)	1
EQ32	Flat Washer, #10 (same as D33)	1
EQ33	Drive Screw, #10 x 1/2" (same as D11)	1
EQ34	Rivit, 3/16, long	2
EQ35	I.D. Tag	1
EQ36	Drive Screw, #6 x 1/4" (same as D13)	2
EQ37	E-Clip w/EQ26	1
EQ39	Rivit, 3/16, small	1

## EQUATE™ SERIES PRESSURE/VACUUM RELIEF VALVE EQUATE™ PV-4



WT. = 46 lbs.

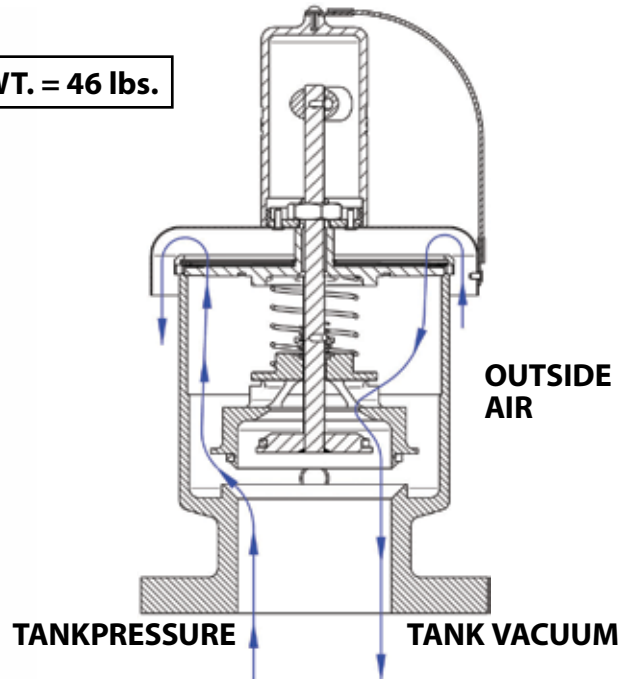

- **AUTOMATIC OPERATION**

The Equate PV-4, 4" P-V Valve is designed to automatically maintain safe design working pressure and vacuum levels within your barge. Your barge remains closed vapor tight until set point pressure or vacuum overcomes the force of each respective set point spring, allowing vapor flow out or air flow in, at a rate sufficient to maintain safe levels within your barge.

- **SIMPLE DESIGN**

Having very few parts, the Equate P-V valve is spring operated with one spring to determine the pressure set opening point and the second spring to determine the vacuum set opening point. A manual test handle allows the tankerman to check operation of both the pressure and vacuum sides of the valve. Both the test handle and valve weather covers are easily removed allowing complete valve inspection in minutes. Easy to replace elastomer seals, one pressure and one vacuum seal, insure vapor tightness.

- **100% STAINLESS STEEL**

All components are 300 series stainless steel for extended service life and reduce need for maintenance. The resilient pressure and vacuum seals are the only parts that are not stainless steel.

- **CERTIFIED TO MEET ALL USCG REQUIREMENTS**

Every Equate P-V Valve is 100% factory tested prior to shipment and is USCG Approved.

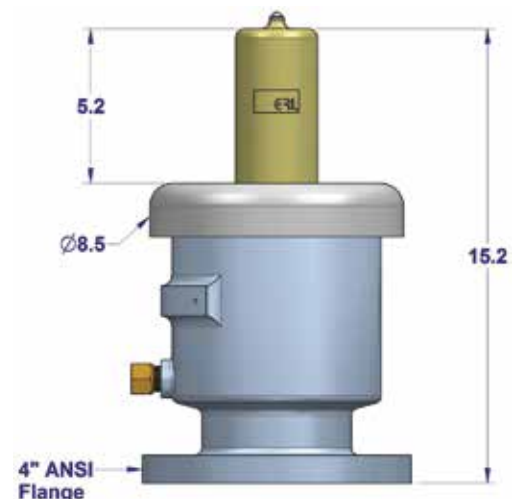



## **EQUATE™ SERIES 4" PV VALVE PRESSURE FLOW CURVES DATA BASED ON AIRFLOW**

LATEST FLOW CURVES AVAILABLE ONLINE AT [WWW.ERLMARINE.COM](http://WWW.ERLMARINE.COM)

**VACUUM CURVES:**

.5 PSI VACUUM  
1.0 PSI VACUUM  
2.0 PSI VACUUM  
3.0 PSI VACUUM

**PRESSURE CURVES:**

1.0 PSI PRESSURE  
1.5 PSI PRESSURE  
2.0 PSI PRESSURE  
2.5 PSI PRESSURE  
3.0 PSI PRESSURE  
5.0 PSI PRESSURE  
6.0 PSI PRESSURE

### EQUATE™ SERIES 4" PV VALVE VACUUM FLOW CURVE DATA BASED ON AIRFLOW

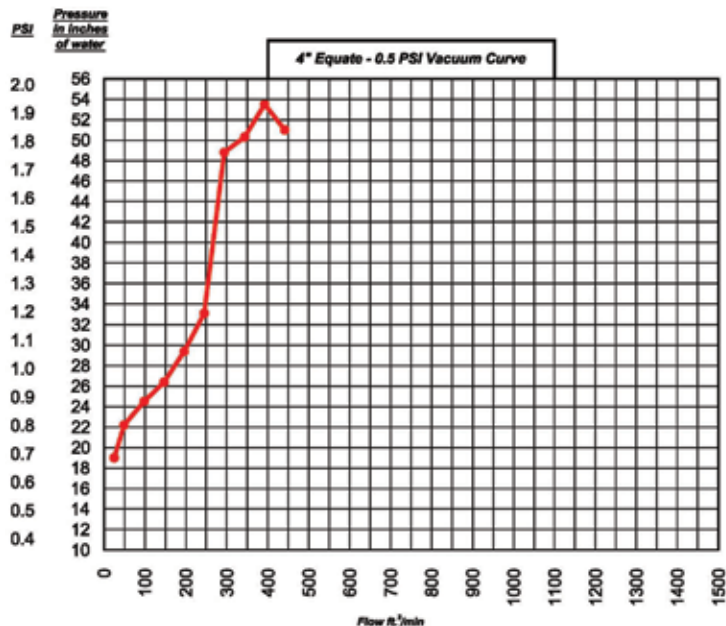

Barrels per hour	Flow ft <sup>3</sup> /min	Pressure in inches of H <sub>2</sub> O
262	25	19.0
524	49	22.2
1048	98	24.5
1571	147	26.4
2095	196	29.4
2619	245	33.1
3143	294	48.8
3667	343	50.3
4190	392	53.5
4714	441	51.0



#### STEP 1

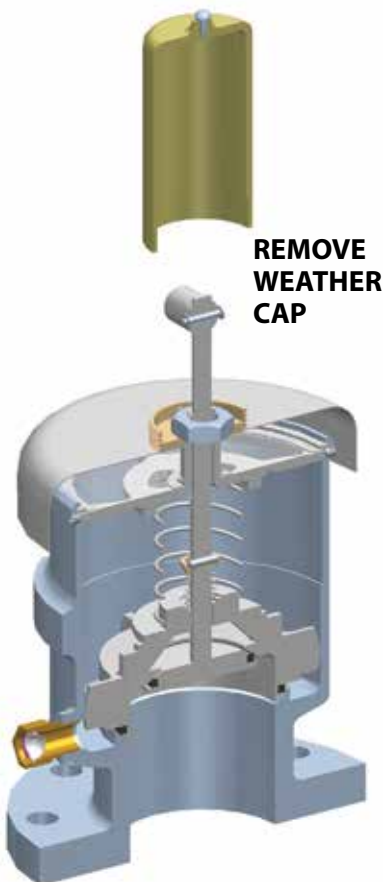

#### STEP 2

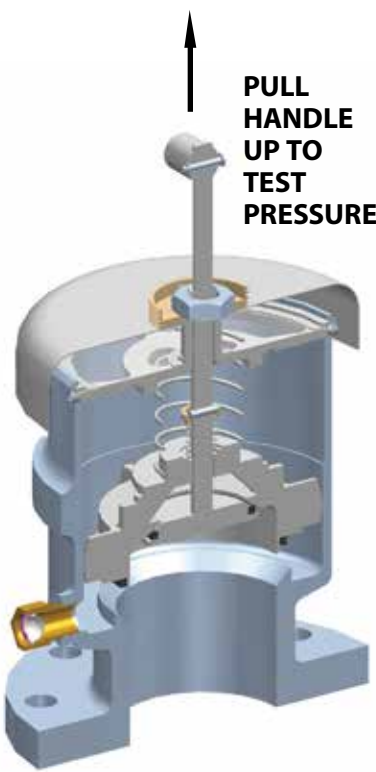

#### STEP 3

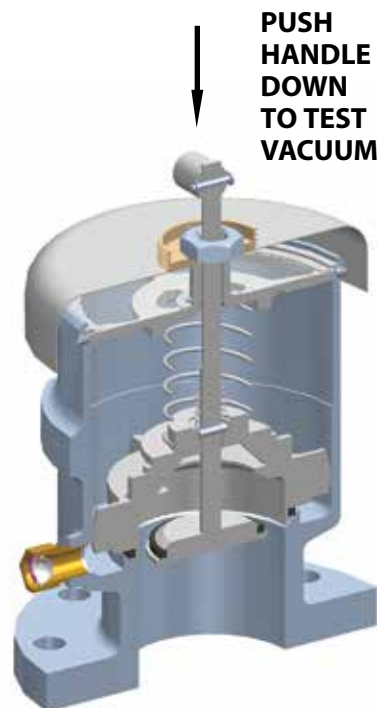



## EQUATE™ SERIES 4" PRESSURE/VACUUM RELIEF VALVE

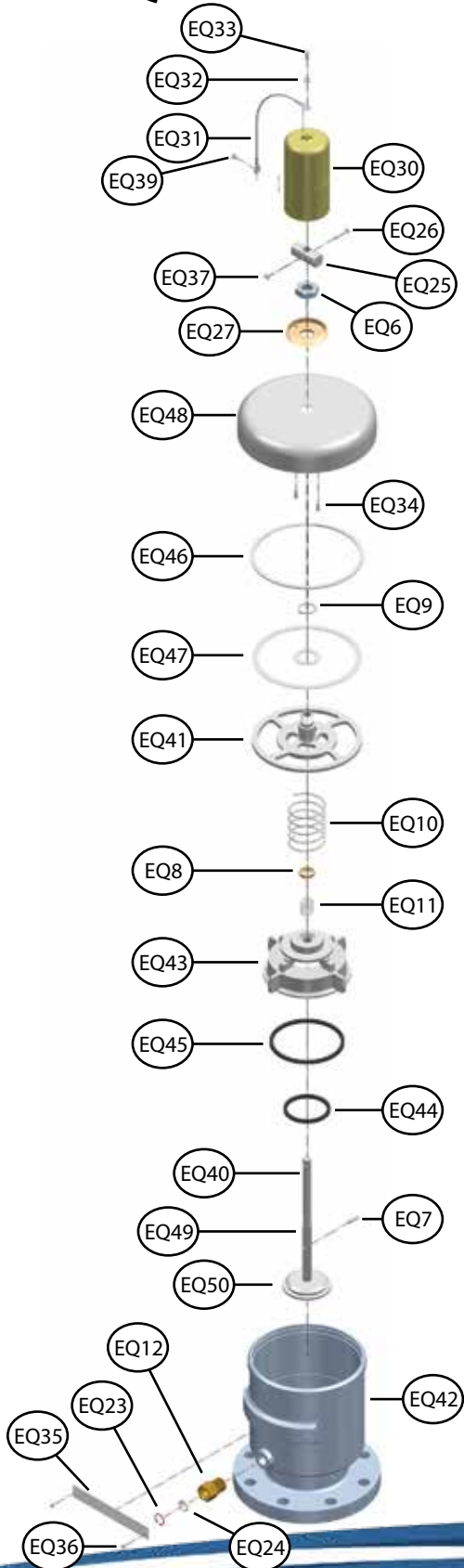

Item	Part Name	Qty.
EQ6	Hex Jam Nut, 3/4-16	1
EQ7	Dowel Pin, 3/16 x 3/4	1
EQ8-A	Spring Retainer	1
EQ9	Ext. Retaining Ring, 1"	1
EQ10	Spring, pressure	see cht
EQ11	Spring, vacuum	see cht
EQ12	Drain Plug	
EQ23	Internal Retaining Ring, 3/4"	1
EQ24	Plug Screen	1
EQ25	Test Knob	1
EQ26	Clevis Pin w/EQ37, 3/16 x 1	1
EQ27	Threaded Bushing	1
EQ30	Knob Cover	1
EQ31	Lanyard (same as D10)	1
EQ32	Flat Washer, #10 (same as D33)	1
EQ33	Drive Screw, #10 x 1/2" (same as D11)	1
EQ34	Rivit, 3/16, long	2
EQ35	I.D. Tag	1
EQ36	Drive Screw, #6 x 1/4" (same as D13)	2
EQ37	E-Clip w/EQ26	1
EQ39	Rivit, 3/16, small	1
EQ40	Stem, weldment	1
EQ41	Top Retainer	1
EQ42	Main Body	1
EQ43	Follower	1
EQ44A	Quadring, vacuum	1
EQ44B	Quadring, vacuum	1
EQ45A	Quadring, pressure	1
EQ45B	Quadring, pressure	1
EQ46	Spiral Retn. Ring	1
EQ47	Flame Screen	1
EQ48	Cover	1
EQ49A	Stem	1
EQ49B	Stem, 2PSI	1
EQ50	Seal Holder	1
EQ51	Follower (casting)	1
EQ52	Main Body (casting)	1
EQ53	Top Retainer (casting)	1

## EQUATE™ SERIES PRESSURE/VACUUM RELIEF VALVE EQUATE™ PV-8



WT. = 105 lbs.

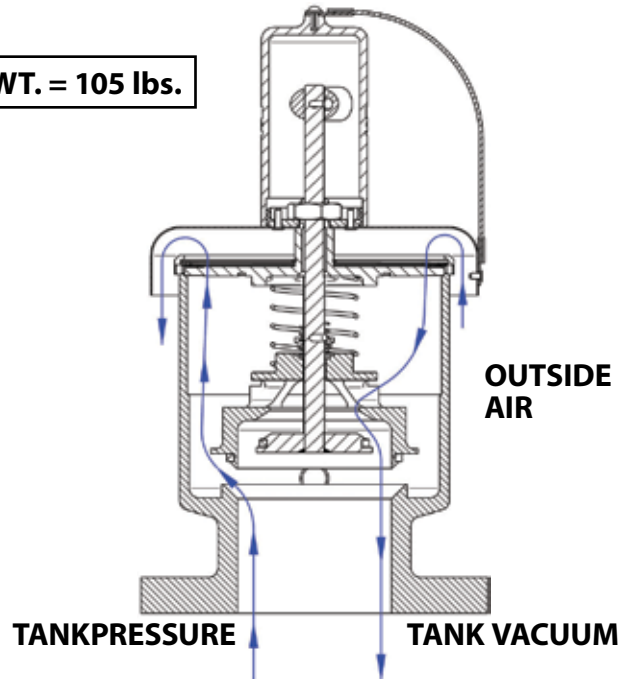

### • AUTOMATIC OPERATION

The Equate PV-8, 8" P-V Valve is designed to automatically maintain safe design working pressure and vacuum levels within your barge. Your barge remains closed vapor tight until set point pressure or vacuum overcomes the force of each respective set point spring, allowing vapor flow out or air flow in, at a rate sufficient to maintain safe levels within your barge.

### • SIMPLE DESIGN

Having very few parts, the Equate P-V valve is spring operated with one spring to determine the pressure set opening point and the second spring to determine the vacuum set opening point. A manual test handle allows the tankerman to check operation of both the pressure and vacuum sides of the valve. Both the test handle and valve weather covers are easily removed allowing complete valve inspection in minutes. Easy to replace elastomer seals, one pressure and one vacuum seal insure vapor tightness.

### • 100% STAINLESS STEEL

All components are 300 series stainless steel for extended service life and reduce need for maintenance. The resilient pressure and vacuum seals are the only parts that are not stainless steel.

### • CERTIFIED TO MEET ALL USCG REQUIREMENTS

Every Equate P-V Valve is 100% factory tested prior to shipment and is USCG Approved.

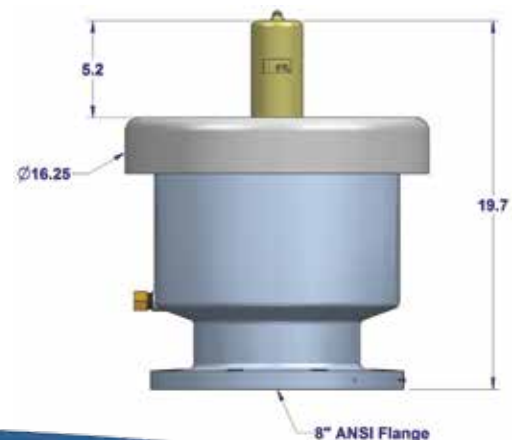



## **EQUATE™ SERIES 8" PV VALVE PRESSURE FLOW CURVES DATA BASED ON AIRFLOW**

LATEST FLOW CURVES AVAILABLE ONLINE AT [WWW.ERLMARINE.COM](http://WWW.ERLMARINE.COM)

**VACUUM CURVES:**

- .5 PSI VACUUM
- 1.0 PSI VACUUM
- 2.0 PSI VACUUM
- 3.0 PSI VACUUM

**PRESSURE CURVES:**

- 1.0 PSI PRESSURE
- 1.5 PSI PRESSURE
- 2.0 PSI PRESSURE
- 2.5 PSI PRESSURE
- 3.0 PSI PRESSURE



## EQUATE™ SERIES 8" PV VALVE VACUUM FLOW CURVE DATA BASED ON AIRFLOW

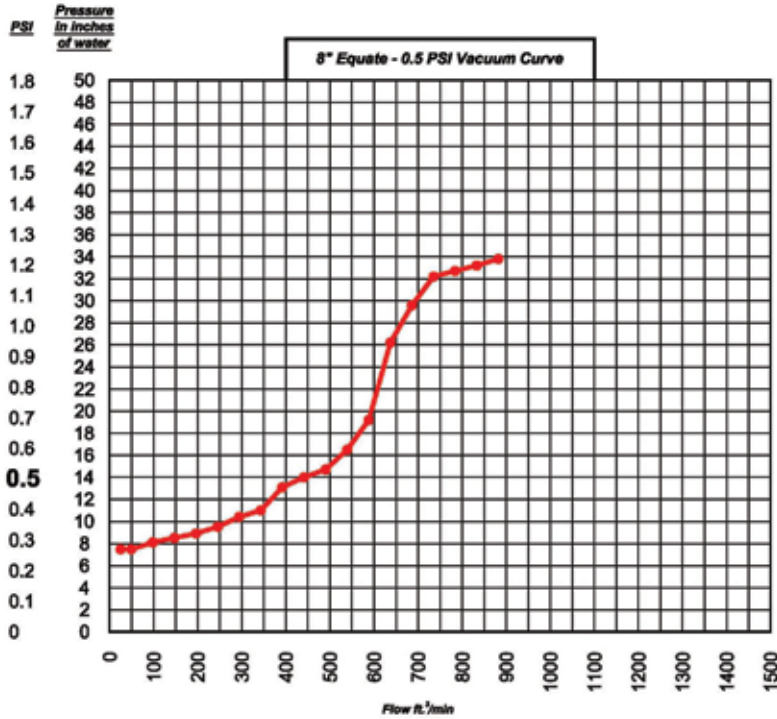

Barrels per hour	Flow ft. <sup>3</sup> /min	Pressure in inches of H <sub>2</sub> O
262	25	7.5
524	49	7.5
1048	98	8.1
1571	147	8.5
2095	196	8.9
2619	245	9.5
3143	294	10.4
3667	343	11.0
4190	392	13.1
4714	441	14.0
5238	490	14.7
5762	539	16.5
6286	588	19.2
6810	637	26.2
7333	686	29.6
7857	735	32.2
8381	784	32.7
8905	833	33.2
9429	882	33.8

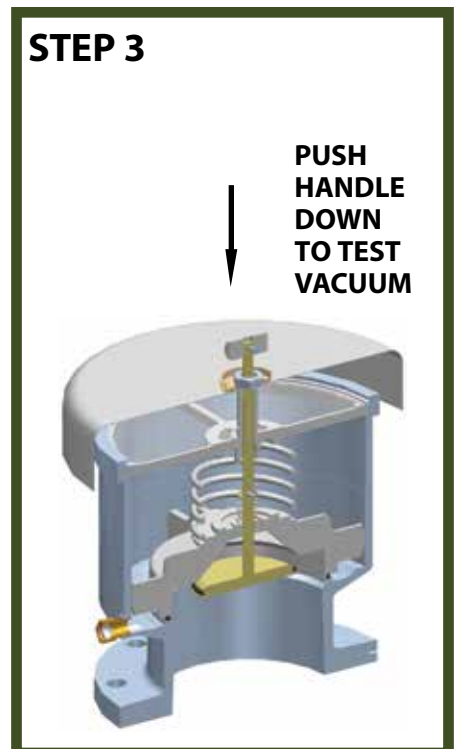
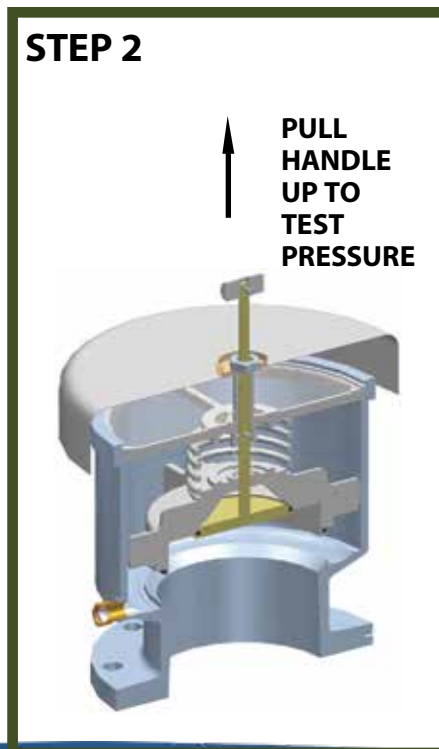
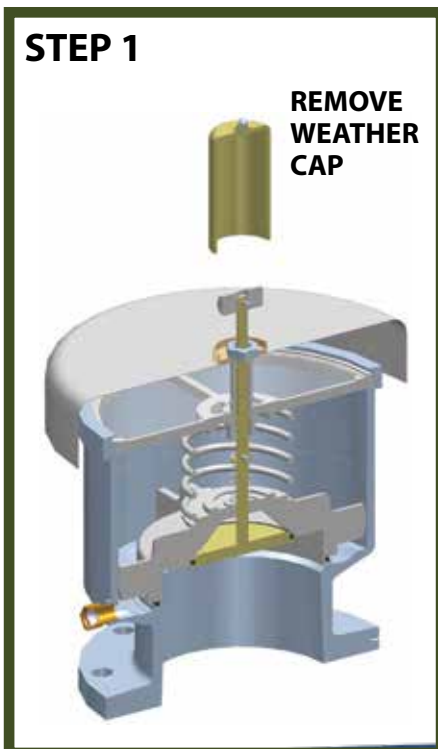
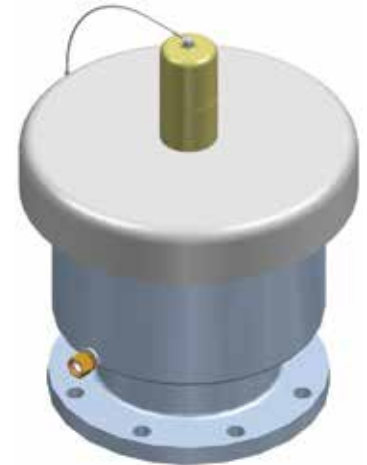



**EQUATE™ SERIES 8" PRESSURE/VACUUM RELIEF VALVE**

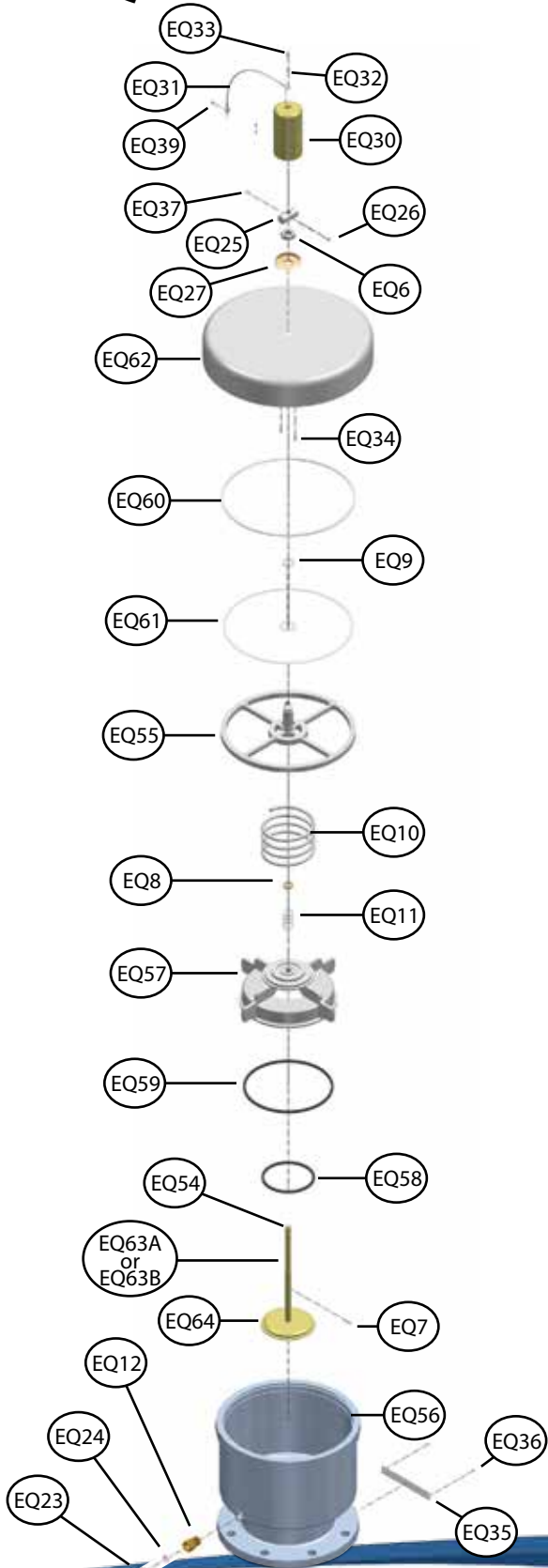

Item	Part Name	Qty.
EQ6	Hex Jam Nut, 3/4-16	1
EQ7	Dowel Pin, 3/16 x 3/4	1
EQ8-A	Spring Retainer	1
EQ8-B	Spring Retainer, 3PSI	1
EQ9	Ext. Retaing Ring, 1"	1
EQ10	Spring, pressure	see cht.
EQ11	Spring, vacuum	see cht.
EQ12	Drain Plug	
EQ23	Internal Retaining Ring, 3/4"	1
EQ24	Plug Screen	1
EQ25	Test Knob	1
EQ26	Clevis Pin w/EQ37, 3/16 x 1	1
EQ27	Threaded Bushing	1
EQ30	Knob Cove	1
EQ31	Lanyard (same as D10)	1
EQ32	Flat Washer, #10 (same as D33)	1
EQ33	Drive Screw, #10 x 1/2" (same as D11)	1
EQ34	Rivit, 3/16, long	2
EQ35	I.D. Tag	1
EQ36	Drive Screw, #6 x 1/4" (same as D13)	2
EQ37	E-Clip w/EQ26	1
EQ39	Rivit, 3/16, small	1
EQ54	Stem, weldment	1
EQ55	Top Retainer	1
EQ56	Main Body	1
EQ57	Follower	1
EQ58A	Quadring, vacuum	1
EQ58B	Quadring, vacuum	1
EQ59A	Quadring, pressure	1
EQ59B	Quadring, pressure	1
EQ60	Spiral Retn. Ring	1
EQ61	Flame Screen	1
EQ62	Cover	1
EQ63A	Stem	1
EQ63B	Stem, 3PSI	
EQ64	Seal Holder	1
EQ65	Follower (casting)	1
EQ66	Main Body (casting)	1
EQ67	Top Retainer (casting)	1

### MARINE FLAME SCREENS

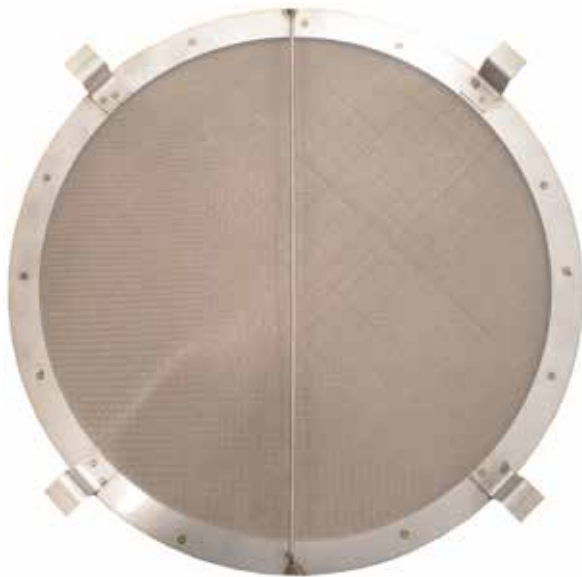

**12" FLAME SCREEN  
WITH CLIPS**

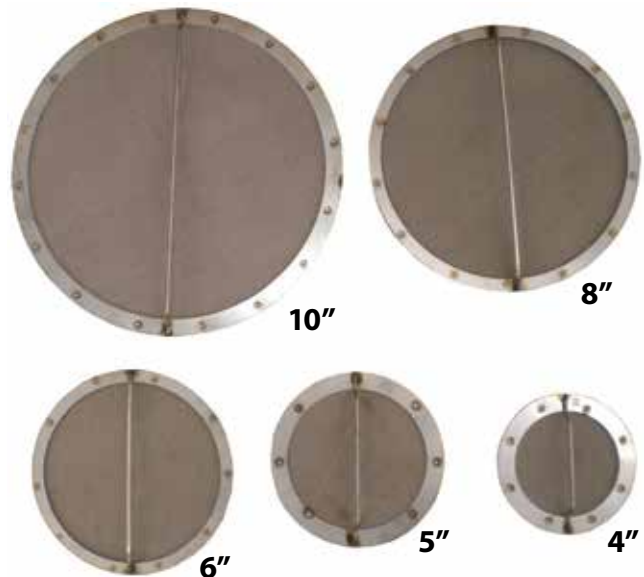

- **FULL COMPLIANCE WITH 46 CFR PART 151, PARA. 151.03-25**

ERL Flame Screens are in full compliance with U.S. Coast Guard Regulations 46 CFR part 39, paragraph 39.20-3(a) and are suitable for use on ABS classed vessels. Our Flame Screens are made from 30 X 30 316SS mesh to provide the optimum resistance to flame propagation while still allowing the tank to breathe.

- **100% STAINLESS STEEL**

The outer rings are cut by computer controlled lasers from stainless steel sheets, yielding Flame Screens of the correct O.D. that fit snugly in the ullage hatch bore as required. A stainless steel low profile handle is welded to each Flame Screen for ease in removal and handling. Our Flame Screens are spot-welded for strength.

- **FULL RANGE OF SIZES**

ERL manufactures a full line of round and oval Flame Screens. When ordering, please specify the O.D. you require. In addition to Flame Screens, ERL can provide wire 30 X 30 316SS mesh in 36" wide rolls.

#### HATCH SCREEN





## PROTECTED FLAME SCREEN VENT (EPV)

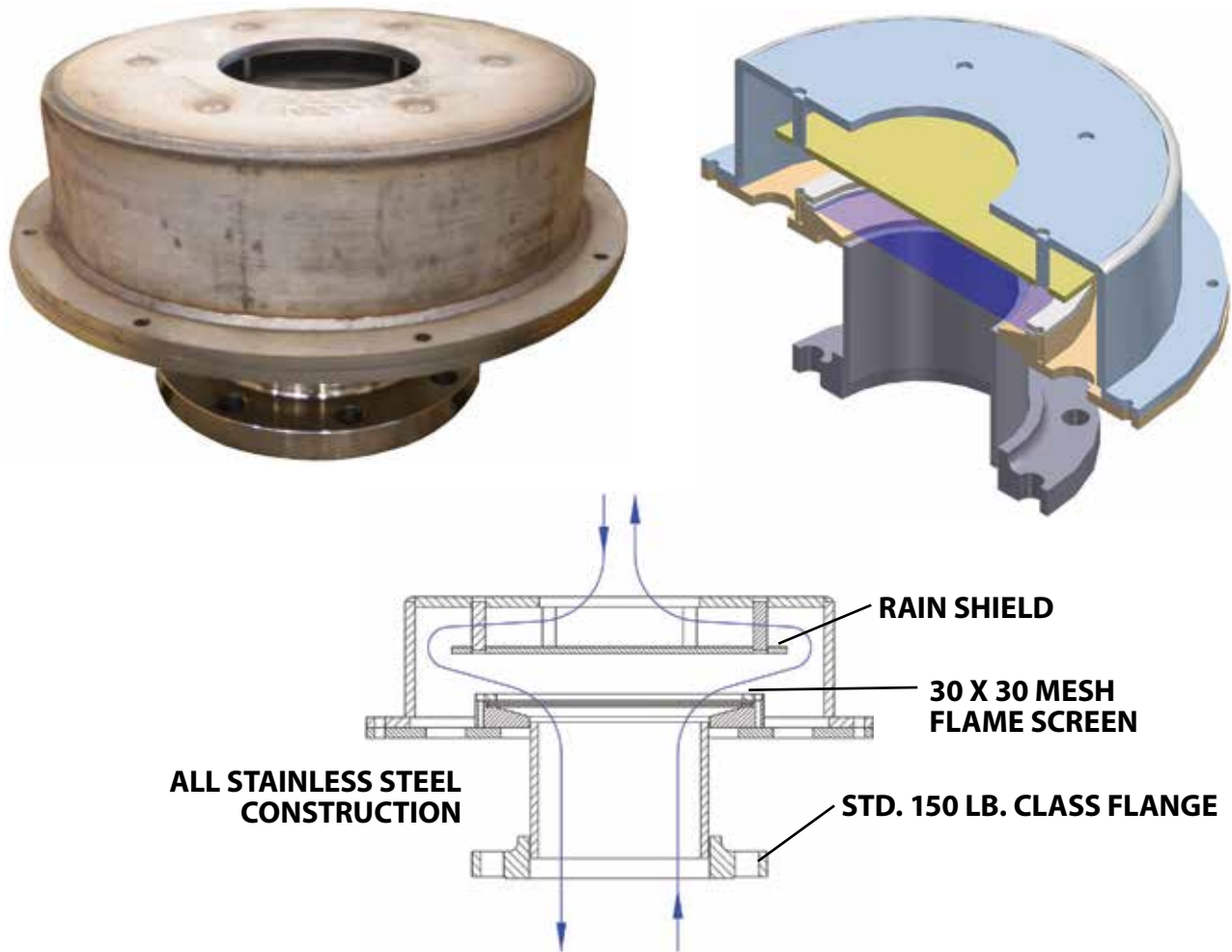

- **100% STAINLESS STEEL CONSTRUCTION**

All components of the ERL Protected Flame Screen Vent are 300 series stainless steel construction allowing for extended service life and a reduced need for maintenance.

- **OPERATIONS**

The ERL Protected Flame Screen vent contains an internal flame screen made from 30 X 30 316SS mesh to provide optimum resistance to flame propagation while still allowing the tank to breathe. The Protected Flame Screen Vent comes with a 150# Class Flange which allows for easy mounting to pipe stand.

- **FULL RANGE OF SIZES**

ERL offers a full range of sizes for the Protected Flame Screen Vent - EPV-4, EPV-6, EPV-8, EPV-10 or EPV-12. When ordering, please specify which size you desire.

## VENT STACK

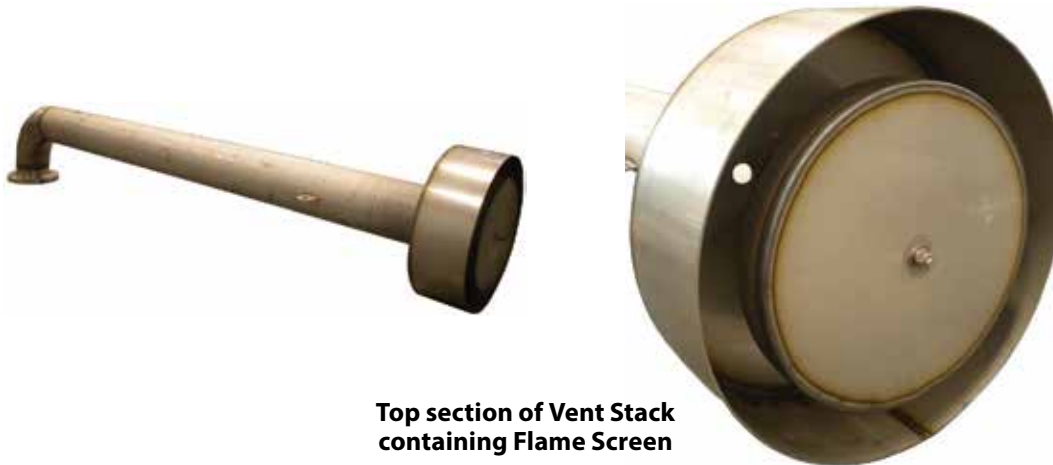

**Top section of Vent Stack  
containing Flame Screen**

- **FULL REGULATORY COMPLIANCE**

ERL Vent Stacks satisfies the requirements of 46 CFR Subpart 32.55 – Ventilation and Venting and includes a 30 X30 316SS mesh Flame Screen which complies with U.S. Coast Guard Regulations 46 CFR part 39, Paragraph 39.20-3 (a).

- **100% STAINLESS STEEL**

All ERL Vent Stacks are constructed from 304 Sch 10 stainless steel ensuring extended service life and a reduced need for maintenance. The top of the Vent Stack contains 30 X 30 316SS Mesh allowing for optimum resistance to flame propagation.

- **MAINTENANCE AND OPTIONS**

Since the ERL Vent Stacks are constructed from 300 series stainless steel it reduces the need for maintenance and the top section of the Vent Stack is easily disassembled for complete inspection of the internal flame screen. ERL offers swivel or ridged mount and the body can be produced from either 8" or 10" 304 sch 10 stainless steel.



**ERL Vent Stack Collapsible -  
mounted on swivel flange.**

NEW!



**PowerHold<sup>TM</sup> 100'**  
Made by ERL Marine

Stainless 40 Ton Winch - 100'  
Capacity - Tank Barge

pg 104

NEW!



**PowerHold<sup>TM</sup> 50'**  
Made by ERL Marine

Stainless 40 Ton Winch - 50'  
Capacity - Tank Barge

pg 105

NEW!



**PowerHold<sup>TM</sup> 50'**  
Made by ERL Marine

Stainless 40 Ton Winch - 50'  
Capacity - Hopper Barge

pg 106

NEW!



Bolt On Wire Swage Holder

pg 107

NEW!



Bolt On Wire Rope Button

pg 108

## STAINLESS 40 TON WINCH – 100' CAPACITY – TANK BARGE



- **IS SAFETY A PRIORITY FOR YOU?**

The deckhand is always in control of the speed. This means no stored energy. Safe release for up to 40 tons. No dogs, No hammers, No cheater bars. You decide.

- **SIMPLE DESIGN**

Smooth Drum gives ease of use to every deckhand. Bolt on Wire swage means every 1" wire will work with our winch, no swedging needed. The swage holder now fully encloses the wire swage.

- **CAN YOU TIGHTEN TO 18,000LBS WITHOUT CHEATER BAR?**

You can with the ERL winch. The ERL 40 Ton winch allows the user to tighten or release the load by simply turning the hand wheel. The winch will release 40 tons and tighten to 9 tons.

- **TWO SPEED DESIGN**

One speed for fast take-up and cable pullout. A second speed for cable tension and load release. This allows the user to tie barges efficiently as well as easily tightening the cable to 18,000 lbs without a cheater bar.

- **BIRDNESTING A PROBLEM?**

It doesn't have to be. The ERL winch does not reel out the cable with a violent release like other designs. This causes bird nesting and difficulty sorting out the cable. The ERL winch releases at your speed.

- **TIRED OF REPLACING WINCHES EVERY 5 YEARS?**

The ERL winch is the industry first stainless steel construction. Every exterior part is stainless steel except the powder coated drum. The entire mechanism is sealed inside with a permanent grease applied. This reduces your lifetime cost and gives you value.



## STAINLESS 40 TON WINCH – 50' CAPACITY – TANK BARGE



- **IS SAFETY A PRIORITY FOR YOU?**

The deckhand is always in control of the speed. This means no stored energy. Safe release for up to 40 tons. No dogs, No hammers, No cheater bars. You decide.

- **SIMPLE DESIGN**

Smooth Drum gives ease of use to every deckhand. Bolt on Wire swage means every 1" wire will work with our winch, no swedging needed. The swage holder now fully encloses the wire swage.

- **CAN YOU TIGHTEN TO 18,000LBS WITHOUT CHEATER BAR?**

You can with the ERL winch. The ERL 40 Ton winch allows the user to tighten or release the load by simply turning the hand wheel. The winch will release 40 tons and tighten to 9 tons.

- **TWO SPEED DESIGN**

One speed for fast take-up and cable pullout. A second speed for cable tension and load release. This allows the user to tie barges efficiently as well as easily tightening the cable to 18,000 lbs without a cheater bar.

- **BIRDNESTING A PROBLEM?**

It doesn't have to be. The ERL winch does not reel out the cable with a violent release like other designs. This causes bird nesting and difficulty sorting out the cable. The ERL winch releases at your speed.

- **TIRED OF REPLACING WINCHES EVERY 5 YEARS?**

The ERL winch is the industry first stainless steel construction. Every exterior part is stainless steel except the powder coated drum. The entire mechanism is sealed inside with a permanent grease applied. This reduces your lifetime cost and gives you value.



## STAINLESS 40 TON WINCH – 50' CAPACITY – HOPPER BARGE



- **IS SAFETY A PRIORITY FOR YOU?**  
The deckhand is always in control of the speed. This means no stored energy. Safe release for up to 40 tons. No dogs, No hammers, No cheater bars. You decide.
- **SIMPLE DESIGN**  
Smooth Drum gives ease of use to every deckhand. Bolt on Wire swage means every 1" wire will work with our winch, no swedging needed. The swage holder now fully encloses the wire swage.
- **CAN YOU TIGHTEN TO 18,000LBS WITHOUT CHEATER BAR?**  
You can with the ERL winch. The ERL 40 Ton winch allows the user to tighten or release the load by simply turning the hand wheel. The winch will release 40 tons and tighten to 9 tons.
- **TWO SPEED DESIGN**  
One speed for fast take-up and cable pullout. A second speed for cable tension and load release. This allows the user to tie barges efficiently as well as easily tightening the cable to 18,000 lbs without a cheater bar.
- **BIRDNESTING A PROBLEM?**  
It doesn't have to be. The ERL winch does not reel out the cable with a violent release like other designs. This causes bird nesting and difficulty sorting out the cable. The ERL winch releases at your speed.
- **TIRED OF REPLACING WINCHES EVERY 5 YEARS?**  
The ERL winch is the industry first stainless steel construction. Every exterior part is stainless steel except the powder coated drum. The entire mechanism is sealed inside with a permanent grease applied. This reduces your lifetime cost and gives you value.



## BOLT ON WIRE Swage HOLDER

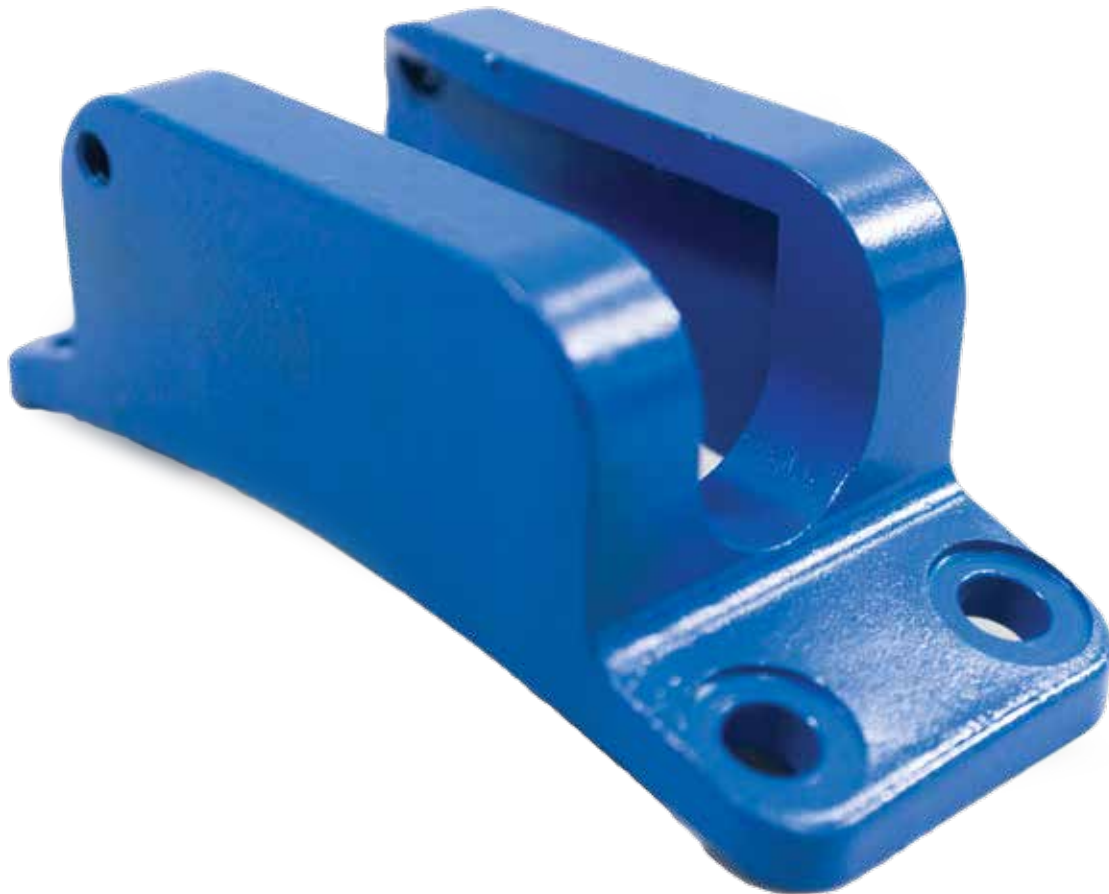

- **SIMPLE DESIGN**

The bolt on swage holder allows the deckhand to simple slide the wire end swage into the swage holder and tighten one hex bolt. The swage holder fully encloses the swage to prevent it from backing out.

- **EASY REPLACEMENT**

If for any reason the swage holder is damaged, the holder can be easily replaced by removing four hex bolts and installing and new holder.

## BOLT ON WIRE ROPE BUTTON EWB-1



- **SIMPLE DESIGN**

The ERL bolt on wire rope button eliminates the need to swedge the wire rope button on the wire. This enables the deckhands to make any wire an ERL winch wire. Simply bolt on the wire rope button at the wire end and install the wire.

- **100% STAINLESS STEEL**

To ensure long life and protect against corrosion every wire rope button is CNC machined from 300 series stainless steel.



## DESCRIPTION OF THE 40 TON WINCH



The ERL 40 ton winch is the first of its kind. It is truly a revolutionary device for barge connection. It is the first winch designed for barges that allows the user to always be in control of the cable. This winch is designed for safe tensioning and releasing of cable. The ERL 40 ton winch has two ratios. The high ratio allows the user to apply up to 18,000 lbs of load to the cable. This ratio also allows the user to release up to 40 tons at the rate the user desires. This ratio is selected by simply lowering the lever located on the opposite side of the hand wheel. To apply load to the cable the user simply turns the hand wheel towards the back of the winch. To release the load the user simply turns the hand wheels towards the front of the winch. This winch does not use dogs to release the load instantaneously. The load is released at the rate the user desires by turning the hand wheel.

The low ratio allows the user to pull out cable easily and take up cable quickly. This ratio does not allow the user to apply load to the cable. The low ratio is selected by raising the lever located on the opposite side of the hand wheel. To take up cable the user simply turns the hand wheel towards the rear of the winch. The winch can hold a capacity up to 100 feet of 1" cable on the drum.

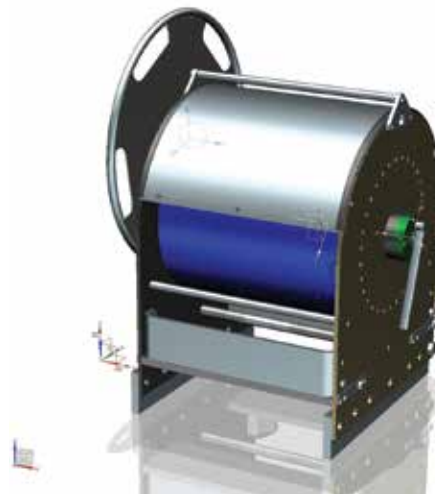

## KEY DESIGN FEATURES

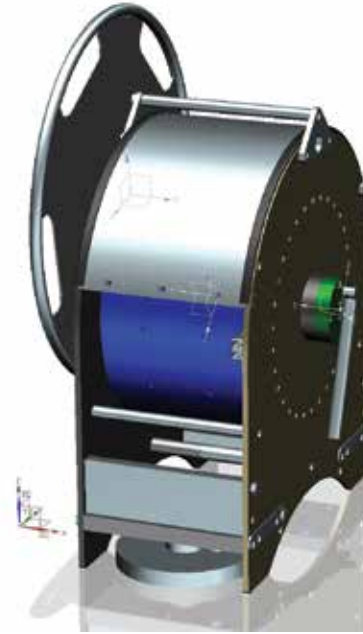
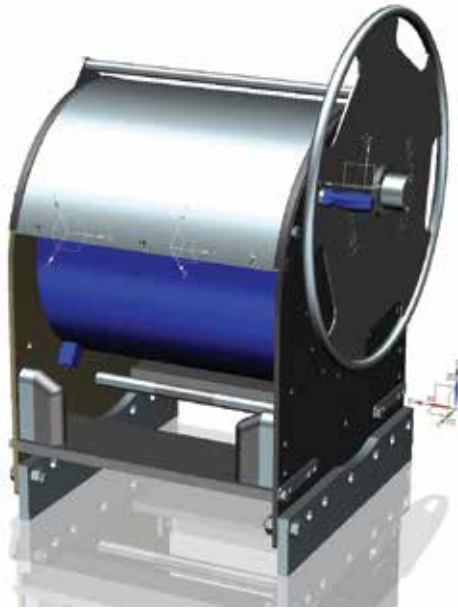

- **LOW WEIGHT: 500 LBS AND 650 LBS RESPECTIVELY**
- **SIMPLE LEVER TO CHANGE SPEEDS**
- **GEARS ARE SELF CONTAINED AND PERMANENTLY LUBRICATED**
- **NO GREASE FITTINGS TO MAINTAIN**
- **TRUE 40 TON CAPACITY WITHOUT YIELDING TEETH**
- **NO EXPOSED GEARING**
- **DRUM CAPACITIES OF 50 AND 100 FEET**
- **ALL EXTERNAL PARTS ARE STAINLESS STEEL OR BRONZE**
- **MANUFACTURED AND ASSEMBLED IN THE USA**
- **TWO PATENTS GRANTED**

## MATERIALS USED

- **STAINLESS STEEL HANDWHEEL ASSEMBLY**
- **BRONZE MAIN BEARINGS**
- **STAINLESS STEEL FRAME**
- **STAINLESS STEEL GEAR LEVER ASSEMBLY**
- **STAINLESS STEEL CABLE ROLLERS**



OVERALL DIMENSIONS

**PowerHold<sup>TM</sup> 50'**  
Made by ERL Marine

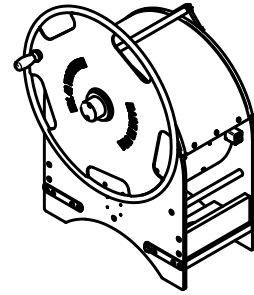
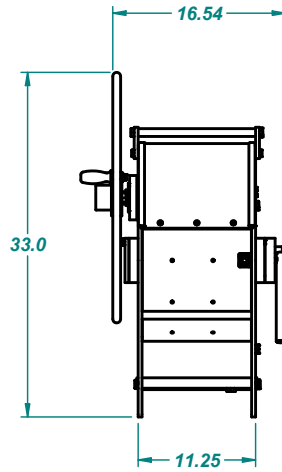
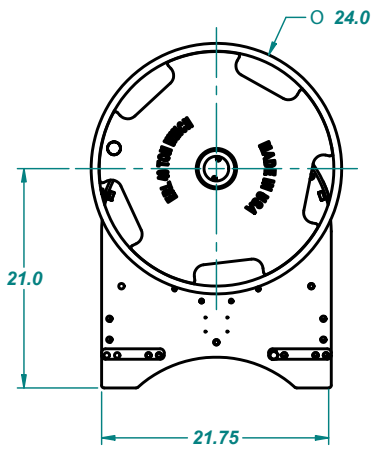
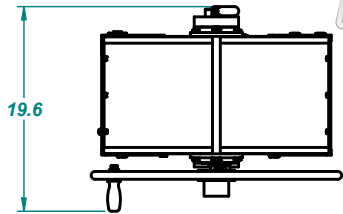

**PowerHold<sup>TM</sup> 100'**  
Made by ERL Marine

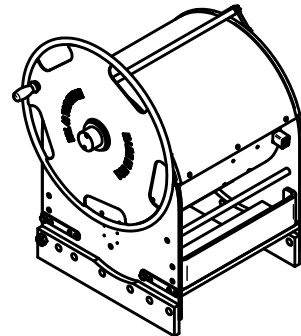
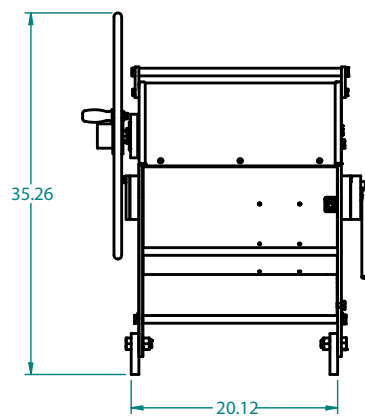
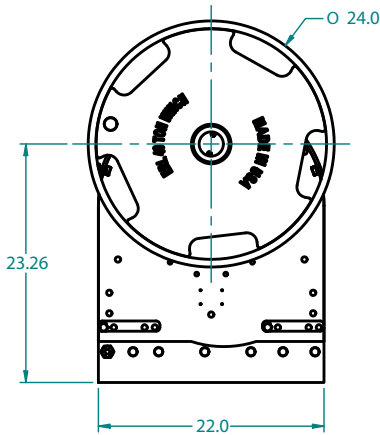
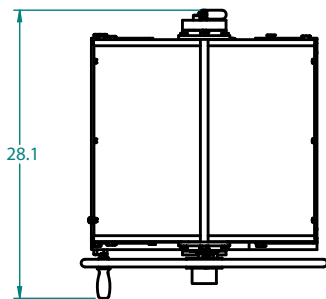

## 40 TON WINCH OPERATING INSTRUCTIONS TIGHTEN CABLE INSTRUCTIONS:

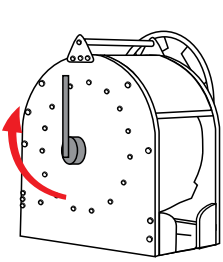

**ROTATE LEVER UP  
(HIGH SPEED)**

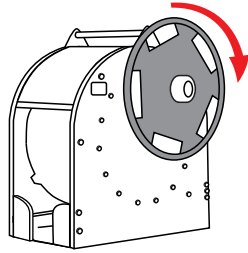

**TAKE UP SLACK  
(HIGH SPEED)**

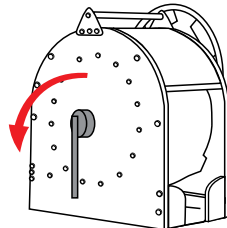

**ROTATE LEVER  
DOWN  
(LOW SPEED)**

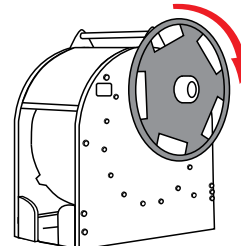

**TIGHTEN WIRE  
(LOW SPEED)**

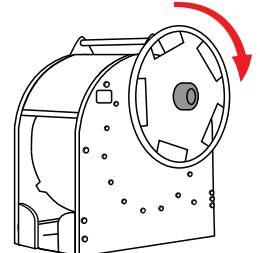

**ENGAGE  
HANDWHEEL LOCK  
(ROTATE LOCK)**

## RELEASING CABLE INSTRUCTIONS:

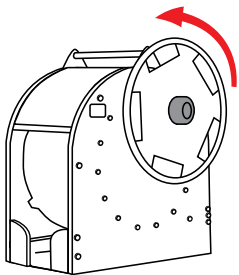

**RELEASE HANDWHEEL  
LOCK  
(ROTATE LOCK)**

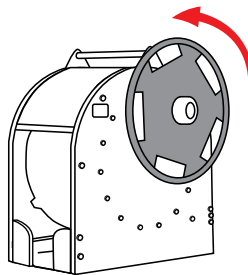

**LET OFF TENSION  
TURN HANDWHEEL  
(LOW SPEED)**

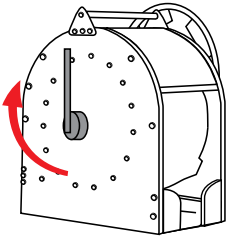

**ROTATE LEVER UP  
(HIGH SPEED)**

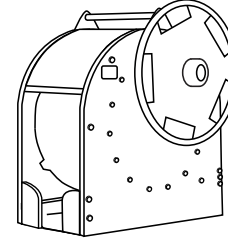

**LET SLACK OUT  
PULL WIRE OUT BY HAND  
(LOW SPEED)**

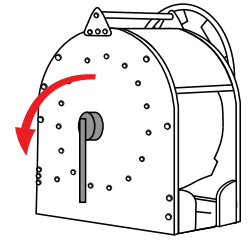

**ROTATE LEVER  
DOWN  
(LOW SPEED)**

### NOTES:

To reel in wire, Turn handwheel toward the rear of the winch.

To release wire, Turn handwheel toward the front of the winch.

Lever Must Be Up to Pullout Wire

Lever Must Be Down to Hold Tension

Do not apply Tension unless at least Two Complete wraps of rope are on the drum.



Marine Scupper Plug  
pg 114



Deck Stands  
pg 115

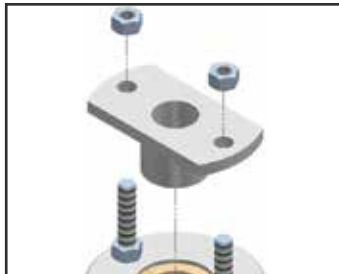

Superseal™ Stuffing  
Boxes  
pg 117

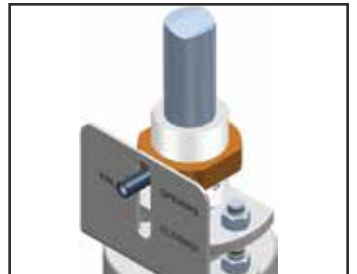

Cargo Valve Position  
Indicators  
pg 121

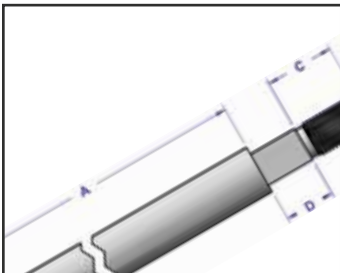

Reach Rod  
pg 124

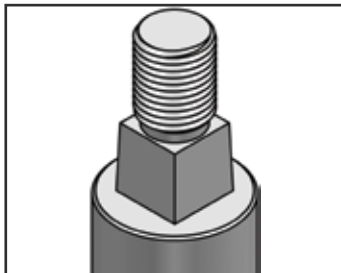

Stem Adapters  
pg 126



Handwheels  
pg 127



Couplers  
pg 128

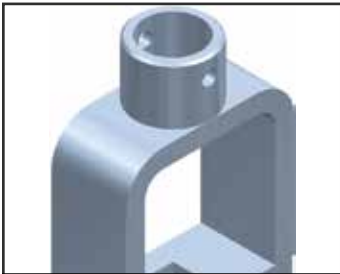

Yokes  
pg 130



Regulatory Signs  
pg 132



Marine Cam Handle  
Scupper Plug  
pg 140



Lip Seal Stuffing Box  
pg 141



U-Joint  
pg 142



Deck Stand - Laser  
Alignment Tool Kit  
pg 143



Stuffing Box - Laser  
Alignment Tool Kit  
pg 144



Pressure/Vacuum  
VibraGauge  
pg 145





## MARINE SCUPPER PLUG



- **FULL REGULATORY COMPLIANCE**

ERL's Scupper Plugs help to ensure your barge meets regulatory compliance of 33 CFR 155.205 – Discharge Removal Equipment for Vessels. Regulations requires that oil tankers and offshore oil barges with an overall length of 400 feet or more must carry appropriate equipment and supplies for the containment and removal of an on-deck oil cargo spills of at least 12 barrels.

- **MATERIALS & OPERATIONS**

All ERL Scupper Plug are constructed from forged EPDM material allowing for superior quality as well as extended product life while in the field. Each Scupper plug comes standard with a bronze hex nut and stainless steel lanyard for to ensure a secure fit. ERL can also offer a bronze wing nut if preferred. For in stock available sizes please refer to the item list. ERL can offer other sizes if desired.

- **3/4" TO 4" CURRENTLY AVAILABLE**

<b>Item #</b>	<b>Description</b>
Scupper Plug 1.5-N	1.5" Scupper plug w/Lanyard and Bronze Hex Nut
Scupper Plug 1.875-N	1.875" Scupper plug w/Lanyard and Bronze Hex Nut
Scupper Plug 2.0-N	2.0" Scupper plug w/Lanyard and Bronze Hex Nut
Scupper Plug 2.2-N	2.2" Scupper plug w/Lanyard and Bronze Hex Nut
Scupper Plug 3.0-N	3.0" Scupper plug w/Lanyard and Bronze Hex Nut
Scupper Plug 4.0-N	4.0" Scupper plug w/Lanyard and Bronze Hex Nut

Bronze Wing Nut is offered as an option.

## DECK STANDS



- **PROPER SUPPORT FOR WEIGHT OF REACH ROD**

The ERL Deck Stand is designed to properly support the weight of long reach rods. The Bronze thrust washer or roller bearing inside the deck stand ensures that the thrust bearing on the valve is not over loaded. Thus preventing premature failure of Valves in tank barges, tank ships or dry docks.

- **VAPOR TIGHT SEAL**

ERL's Superseal Stuffing box seals around the reach around with Teflon Packing to prevent cargo vapor release.

- **TWO MOUNTING CONFIGURATIONS**

Mounting Configurations include weld-down to deck or flanged mount.

- **DRIVE OPTIONS**

The Deck stand and reach rod can be driven by either an ERL fabricated 100% Stainless Steel Construction Handwheel or by Actuator mounted to the deck stand.

- **COMPLETE ASSEMBLY AVAILABLE**

Deck stand can be provided complete with 100% Stainless Steel Handwheel, Valve Position Indicator, Stuffing Box, Reach Rod, and Yoke Connection for a complete assembly from the deck to the valve.

## DECK STANDS

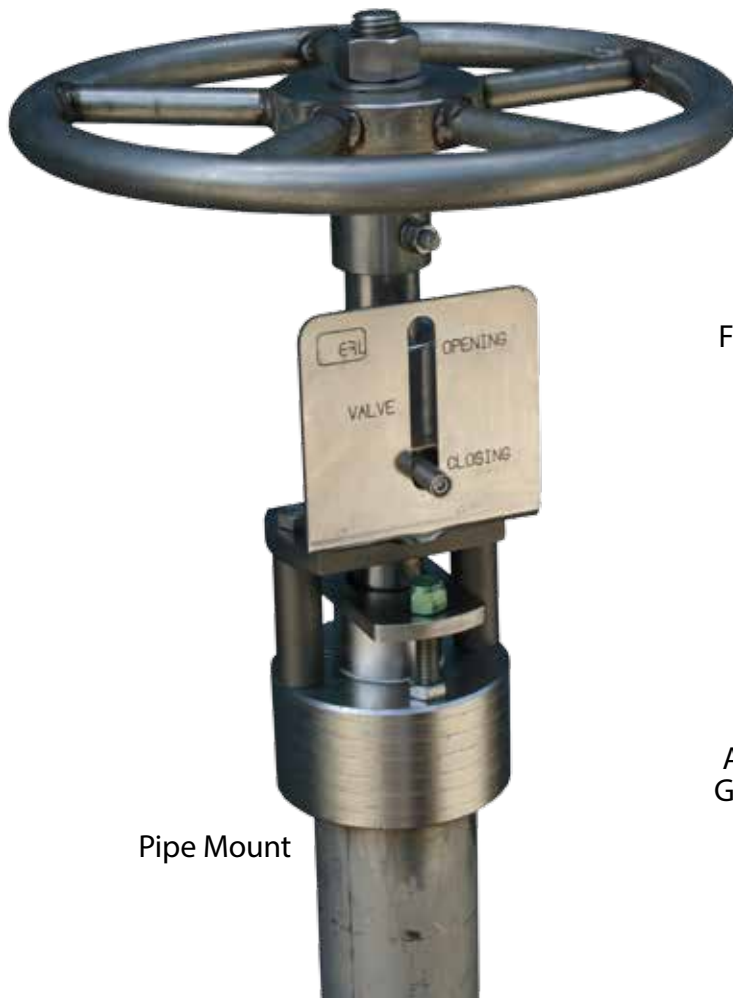

Pipe Mount

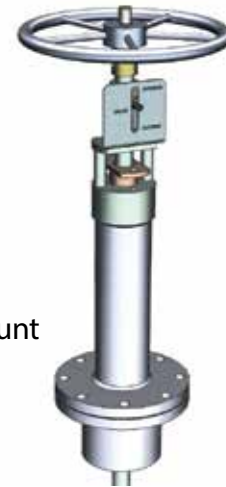

Flange Mount

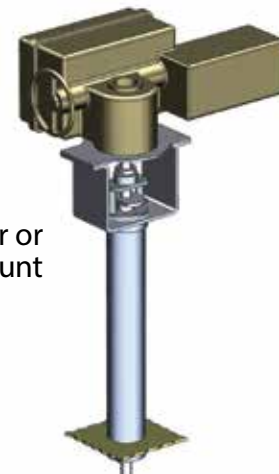
Actuator or  
Gear Mount

- **CONSTRUCTION:** The Deck stand can be fabricated from 100% Stainless Steel or Carbon Steel.
- **SIZES:** Available for reach rod sizes  $\frac{3}{4}$ " thru  $1 \frac{3}{4}$ "
- **VALVE CONNECTION:** Yoke utilizes a slip joint connection available for the Reach Rod to allow for vertical relief at the valve connection.
- **AVAILABLE WITH ERL SUPERSEAL STUFFING BOX WITH THE FOLLOWING OPTIONS:**
  - Flanged Mounting provides 2 bearing locations at deck stand
  - Bronze Thrust Washer for Reach Rod Support
  - Optional Roller Bearing upgrade for Reach Rod Support



## SUPERSEAL™ REACH ROD STUFFING BOX

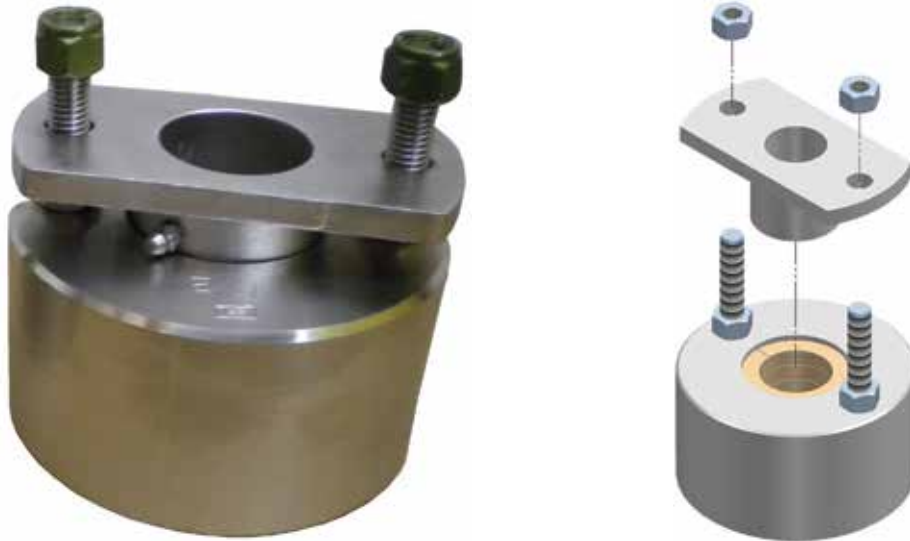

- **100% STAINLESS STEEL CONSTRUCTION**

ERL's SUPER SEAL™ Reach Rod Stuffing Box is completely constructed of 300 series stainless steel. Produced on computer controlled machines to accurately control dimensional quality, the body of the stuffing box is a massive 5" diameter to prevent deformation of the bore from the heat of welding during installation.

- **VAPOR TIGHT PERFORMANCE**

Die cut Teflon™ Packing Rings are designed to fit perfectly in each size Stuffing Box forming an effective vapor tight seal preventing fugitive emissions. The "T" shaped gland draws downward to lightly compress the Teflon™ packing. Two Teflon™ coated Steel nuts maintain the glands compression setting on the packing. A grease fitting on the gland allows the introduction of grease between the reach rod and the bore of the gland. Grease lubrication lubricates while further reducing fugitive emissions. For best long term performance the reach rod should be stainless steel. In any case the reach rods surface must be smooth.

- **EASY INSTALLATION**

ERL stocks the most popular size stuffing boxes, as listed below, other sizes are produced as requested. Standard Stuffing Boxes can be flush mounted, a counterbore also permits mounting on a 2.5", 3", or 4" pipe. Other size counterbores, including threaded counterbores, are produced as requested.

- **AVAILABLE VALVE POSITION INDICATOR**

All size Stuffing Boxes are designed to easily accommodate the ERL Valve Position Indicator. Save time and money by installing the Valve Position Indicator and Stuffing Box at the same time. Additionally ERL can provide Handwheels, Stem Adapters, Reach Rods, Couplings and Yokes.

## SUPERSEAL™ REACH ROD STUFFING BOX

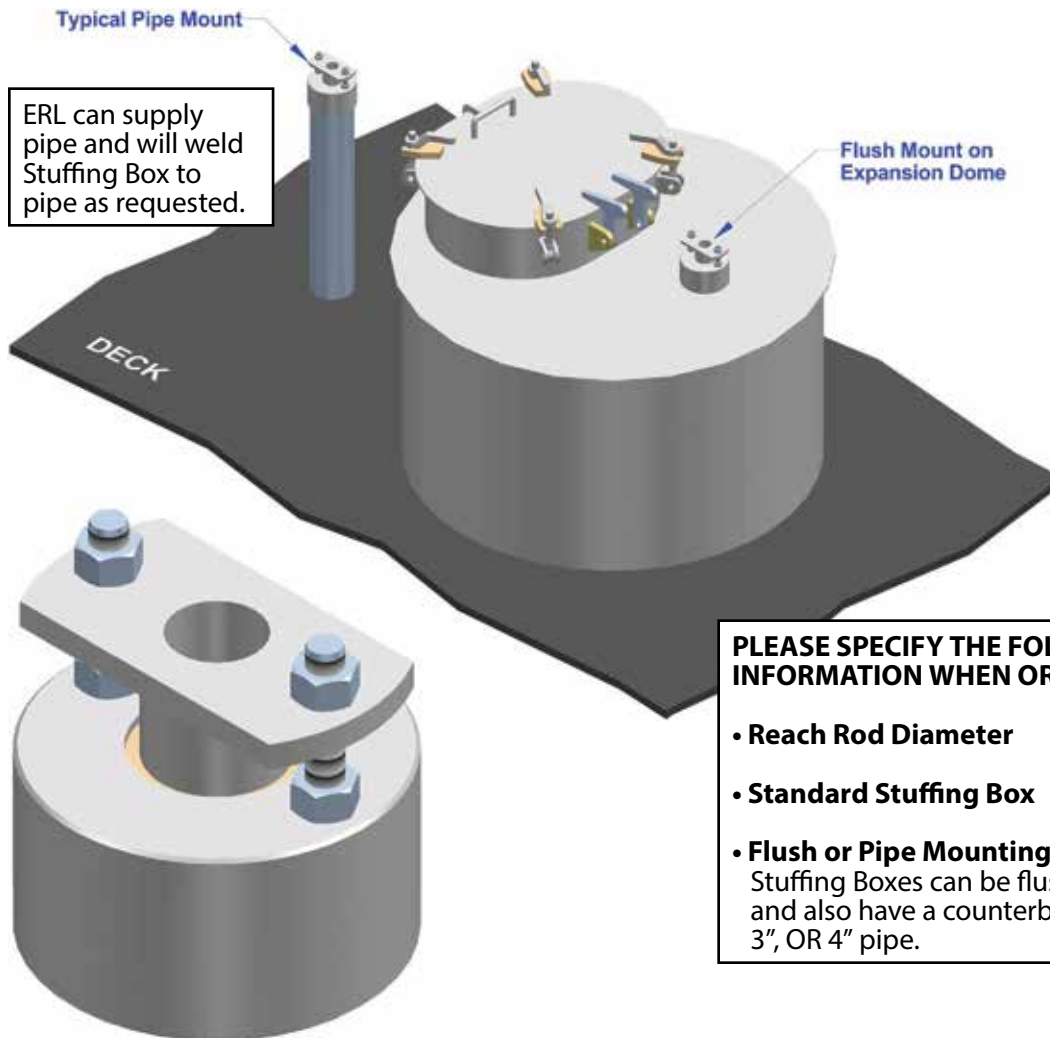

**PLEASE SPECIFY THE FOLLOWING INFORMATION WHEN ORDERING -**

- Reach Rod Diameter
- Standard Stuffing Box
- Flush or Pipe Mounting. All ERL Stuffing Boxes can be flush mounted and also have a counterbore for a 2.5", 3", OR 4" pipe.

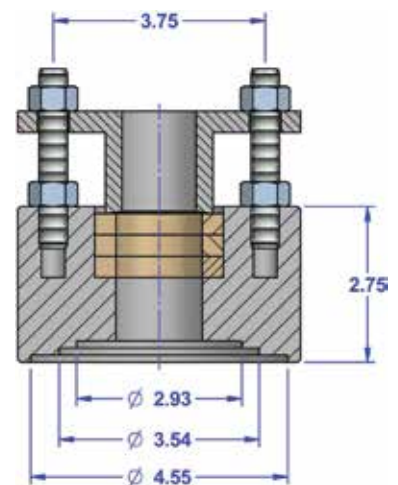
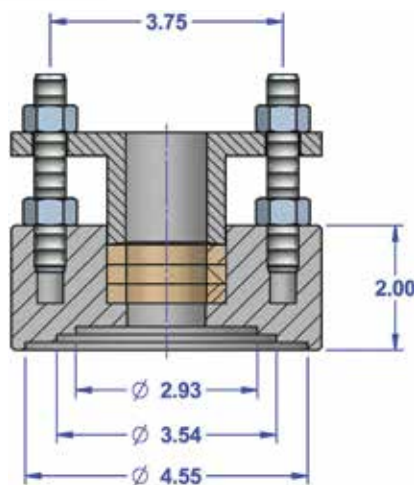
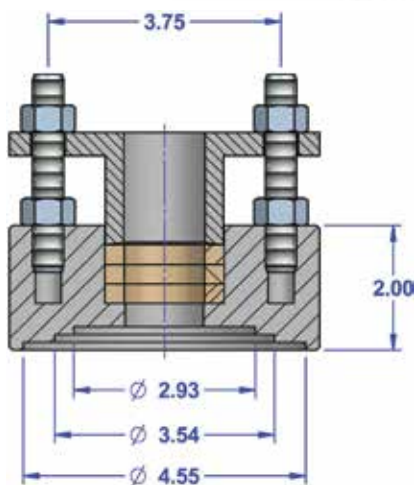



### SUPERSEAL™ STUFFING BOX/VALVE POSITION INDICATOR ASSEMBLY DRAWING

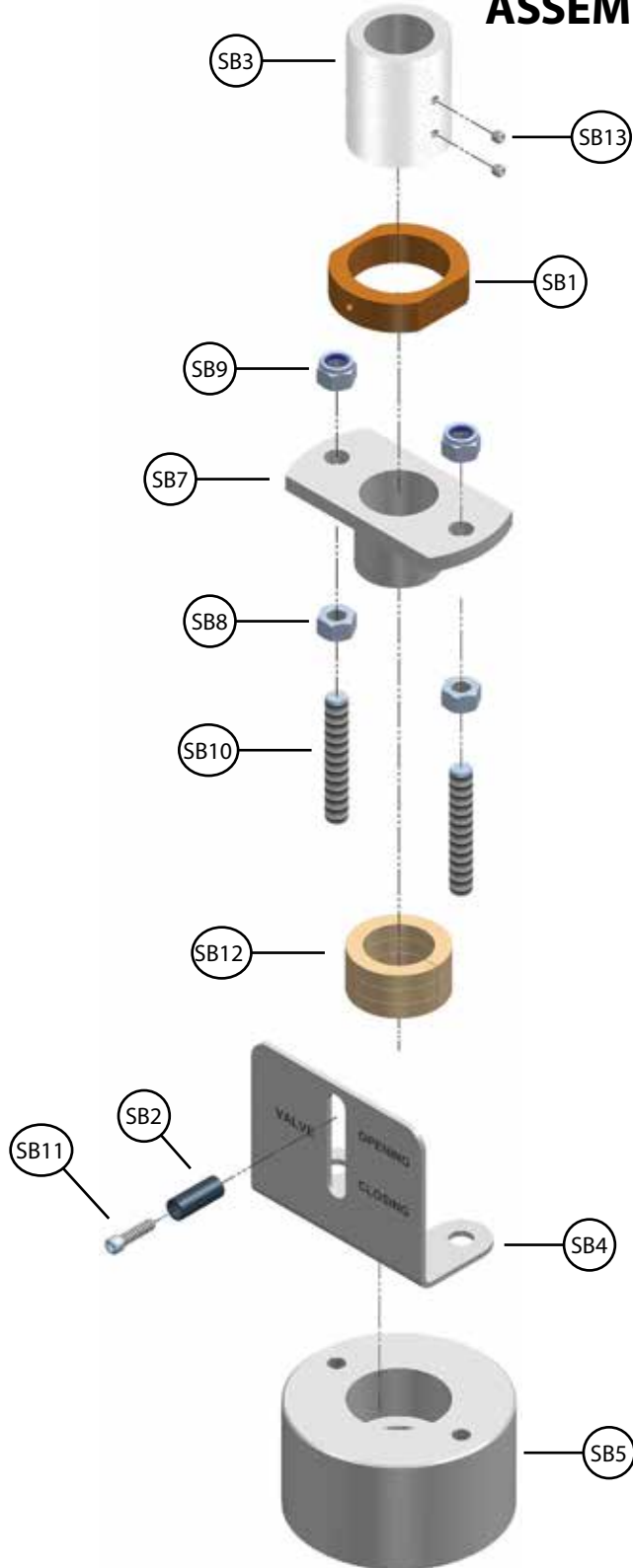

Item	Part Name	Qty.
SB1	Indicator Nut	1
SB2	Indicator Peg	1
SB3	Threaded Bushing	1
SB4	Indicator Plate (Short or Tall)	1
SB5	Stuffing Box	1
SB7	Gland	1
SB8	Hex Nut, stainless	2
SB9	Hex Nut, teflon coated	2
SB10	Stud	2
SB11	S.H.C.S.	1
SB12	Packing	
Stuffing box size:		3/4" 1" 1-1/4" 1-1/2" 1-5/8"
Thickness of packing:		5/16" 5/32" 5/16" 3/8" 5/16"
Number of Rings:		3 5 3 3 3
SB13	SETSCREWS	2

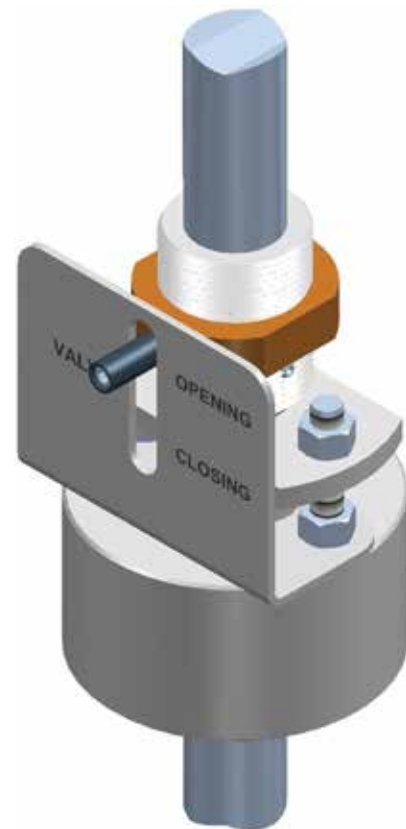

## CARGO VALVE POSITION INDICATOR

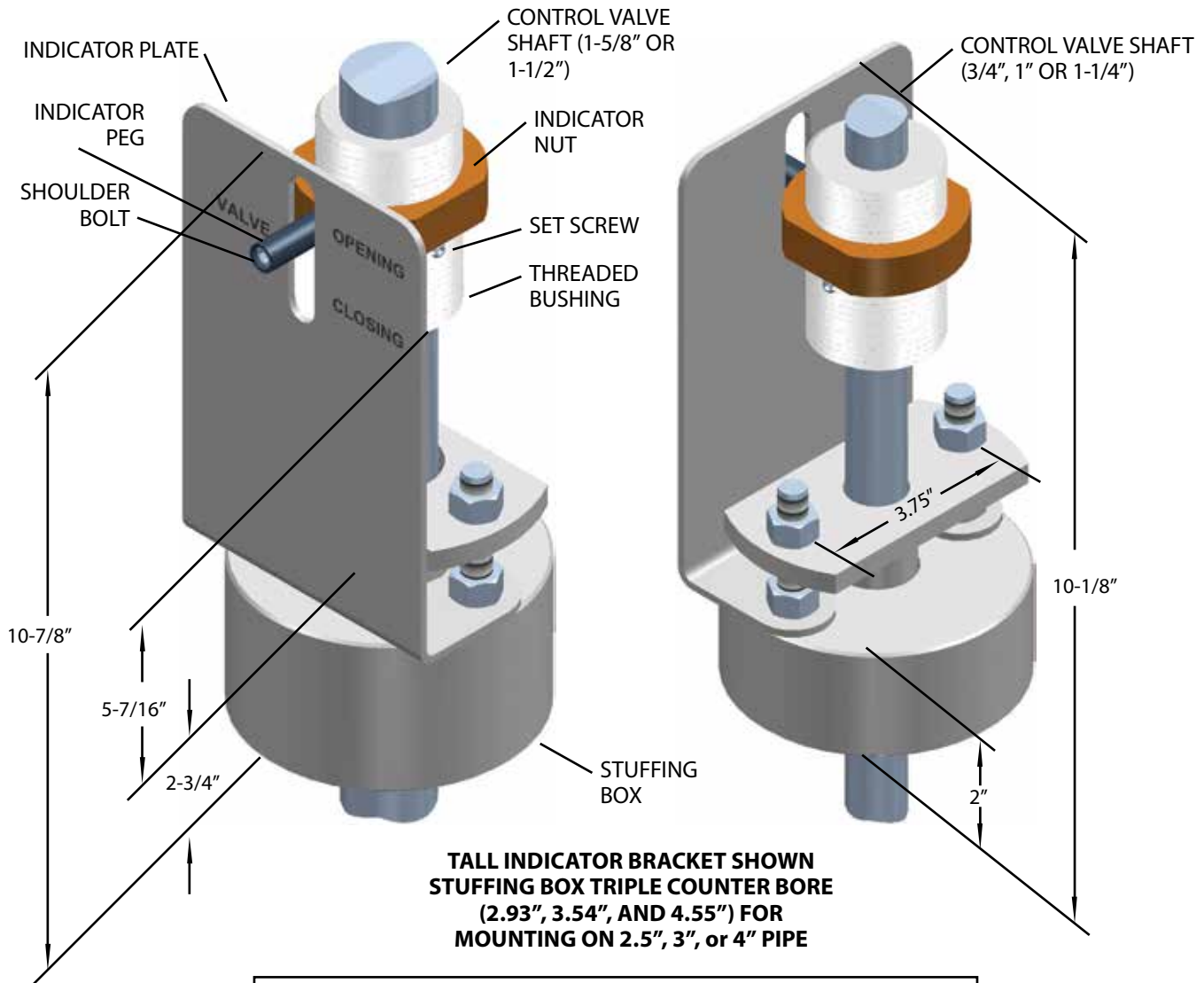

**When ordering ERL's valve position indicator, simply specify:**

- The reach rod diameter.
- The number of turns full open to full closed on the cargo valve.
- Short or tall indicator plate.
- For use with superseal stuffing box or other.

### • EASY INSTALLATION

Our threaded stainless steel Valve Position Indicator bushing, item #3, is designed to easily fit the reach rod, while the indicator plate bolts to the Superseal Stuffing Box. A special indicator bracket with slotted mounting holes may need to be provided to fit non-ERL stuffing boxes. We offer two standard indicator plates, one short and one tall. The short indicator plate is for retrofit installations when there is little distance between the hand wheel and the stuffing box. The tall indicator plate is recommended on all installations if vertical space allows, as the tall indicator plate allows complete access to the stuffing box packing.



## CARGO VALVE POSITION INDICATOR



- **REGULATORY COMPLIANCE**

ERL's valve position indicator satisfies 46 CFR 56.20-9(a), which requires an indicating device on non-rising stem valves. Not only does our Cargo Valve Position Indicator satisfy a legal requirement, it can help you to prevent costly damage to equipment and possible overfill cargo spills.

- **QUALITY HEAVY DUTY CONSTRUCTION**

Manufactured entirely from 300 series stainless steel and solid brass on computer controlled machines, ERL's simple valve position indicator design will give you many years of trouble-free service.

- **INSTALLATION FLEXABILITY**

ERL manufactures a variety of indicator brackets allowing you to have off the shelf custom fit with non-ERL stuffing boxes. Our custom stock brackets can fit a stud distance from 3.75" to 5.5" or 2.5" diameter round stuffing box's.



## CARGO VALVE POSITION INDICATOR PLATES 304 STAINLESS STEEL

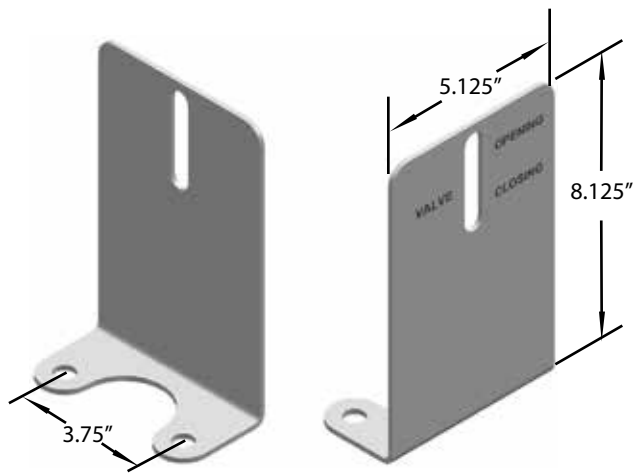

**STANDARD TALL INDICATOR PLATE**

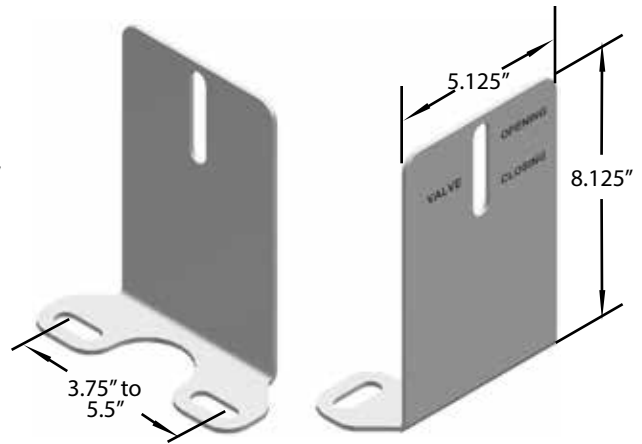

**SPECIAL TALL INDICATOR PLATE**

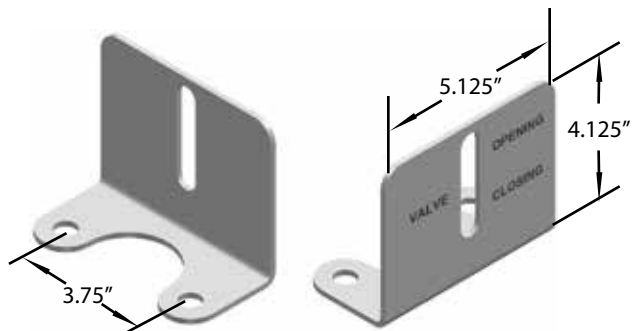

**STANDARD SHORT INDICATOR PLATE**

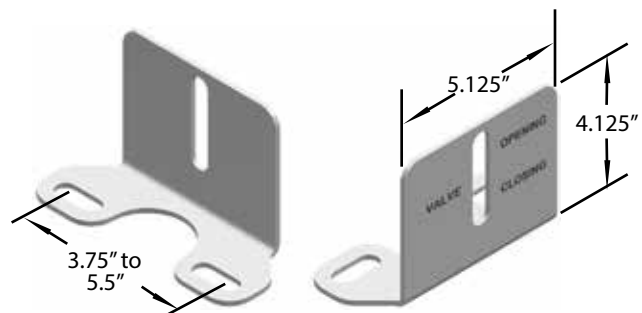

**SPECIAL SHORT INDICATOR PLATE**



ERL's CONTROL VALVE OPERATING SYSTEM

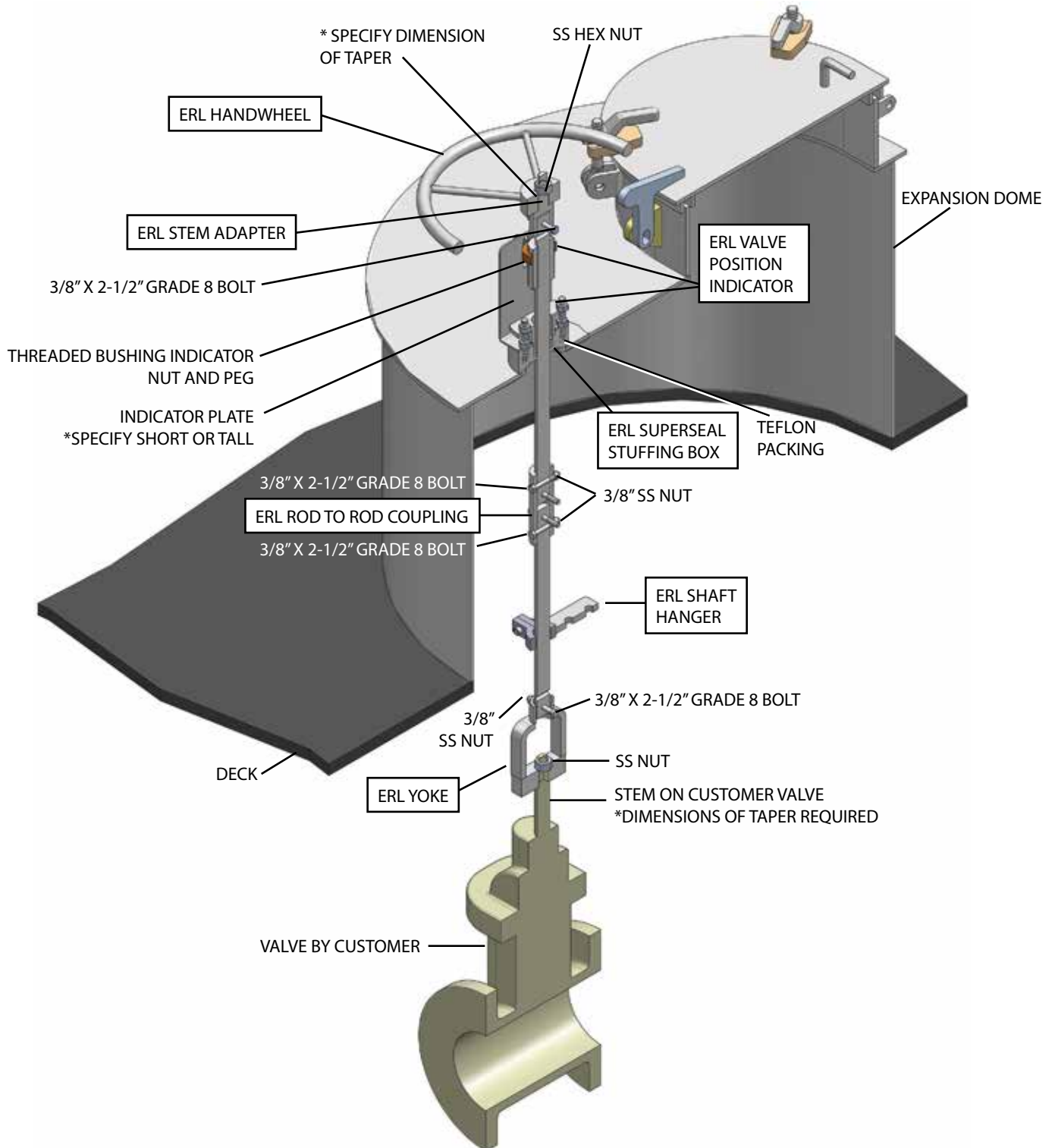

## REACH RODS • STEM ADAPTERS • HANDWHEELS • • COUPLINGS • YOKES •



### • REACH RODS

ERL Reach Rods are all 300 series, corrosion resistant, 100% stainless steel for extended service life. Full length Reach Rods can be provided as well as 2 part Reach Rods with coupling. One end can be machined to fit the Handwheel, but in many cases a Stem Adapter reduces the installed cost of the reach assembly. Brass, Stainless Steel, or Mild Steel shaft hangers are available for long reach rods.

### • STEM ADAPTERS

Machined on computer controlled equipment from solid 300 series stainless steel bar stock, ERL's Stem Adapters represent the most simple economical way to ensure a perfect Handwheel to reach rod fit. ERL's Class III threads, matched stainless steel nut and heavy flat washer secure the steel nut and the heavy flat washer secure the Handwheel safely, yet allow it to easily be removed without applying heat and force. For ultimate flexibility the Stem Adapter can be either bolted or welded to unmachined stainless steel bar stock.

### • HANDWHEELS

Available in a variety of popular diameters, ERL's heavy duty Handwheels all have stainless steel hubs, and five stainless steel spokes (each 3/4" diameter) connect the hub to the solid 1" diameter rolled stainless steel outer ring. The corrosion resistant hub insures long life and easy removal from the Reach Rod.

### • COUPLERS

ERL machines stainless steel rod-to-rod Couplings from solid bar stock to insure a perfect fit to your reach rod O.D. 6" long Couplings are drilled to accommodate the bolting together of two solid rods. The Coupling can be welded on one or both ends if desired. A two part Reach Rod with a bolted Coupling is easy to install and facilitates future service of the Reach Rod.

### • YOKES

ERL's stainless steel rod-to-valve Yoke, represents the most simple, economical way to connect the lower end of the Reach Rod to the liquid control valve. Bolted or welded to the lower end of the Reach Rod the bottom of the Yoke bolts to the valve stem.



**REACH RODS**

**Reach Rod with integral square  
STRAIGHT shank and threaded  
for specified Handwheel.**

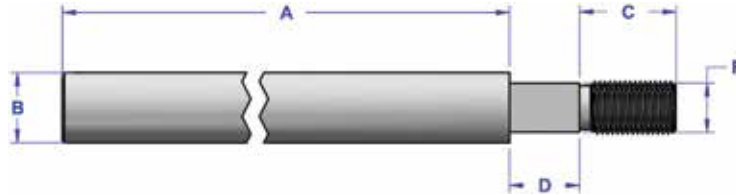

**Reach Rod with integral square  
TAPER shank and threaded  
for specified Handwheel.**

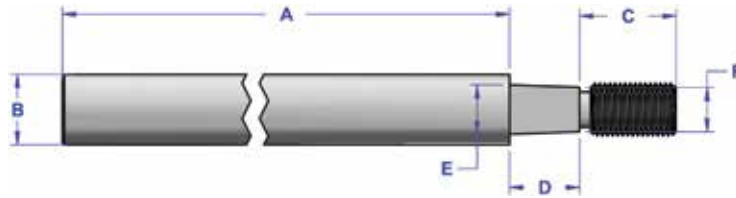

**Reach Rod with integral square  
STRAIGHT shank Handwheel  
drilled and tapped  
for mounting bolt.**

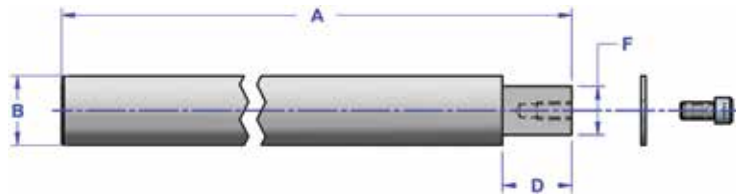

**Reach Rod with integral square  
TAPER shank Handwheel  
drilled and tapped  
for mounting bolt.**

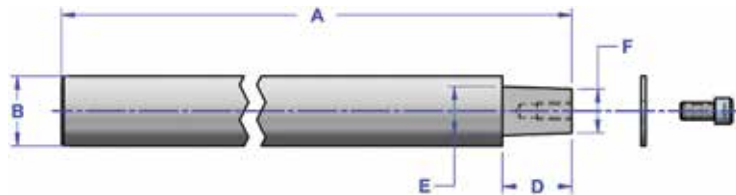

ERL Reach Rods are all manufactured from 300 series, corrosion resistant, stainless steel for extended service life under all conditions. Full length Reach Rods can be provided, as well as, the easier to install, coupled upper and lower Reach Rods. The Handwheel adapter can be machined integral to the Reach Rod or you can use one of ERL's Stem Adapters if you are looking for the ultimate in installation flexibility. Refer to the drawings above and the Ordering Information Table below when ordering. Take care to preserve the reach rods smooth finish in way of the stuffing box.

**ORDERING INFORMATION TABLE**

Reach Rod Style	A Length	B Diameter	C Thread Length	D Flat Length	Flat Dimension	
					E Bottom End	F Top End
Square					n/a	
Taper						
Round			n/a	n/a	n/a	n/a

## STEM ADAPTERS

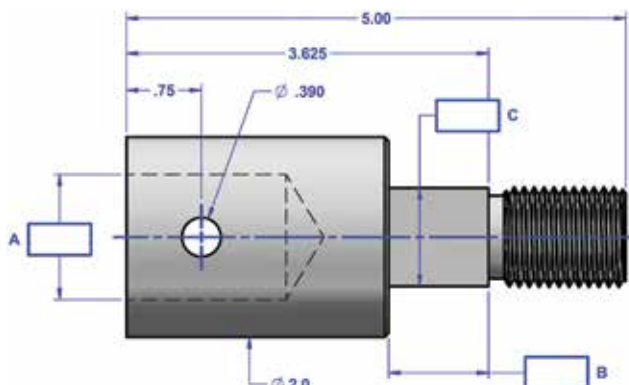
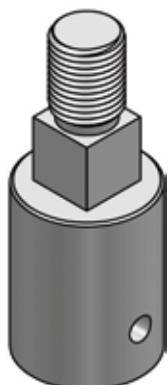
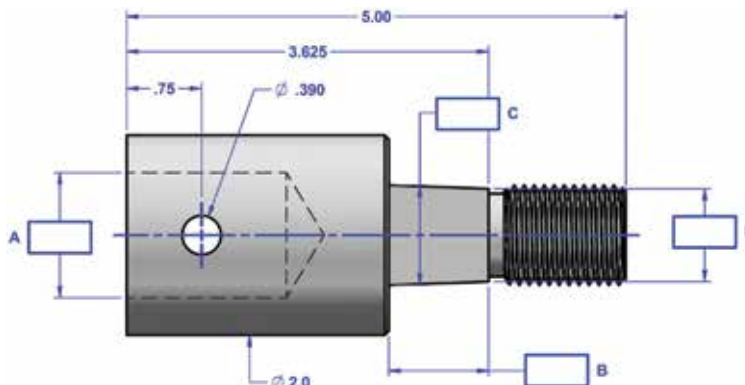
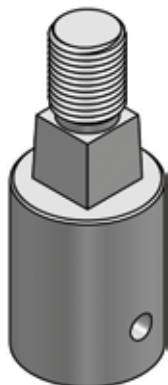

ERL stainless steel Stem Adapters are easy to use and they save you money. Class III threads and CNC machining quality insure both good fit and the ability to easily remove the handwheel without heat or destructive force. Simply weld or bolt the Stem Adapter, which has been machined to perfectly fit your handwheel, to an un-machined stainless steel bar stock for a perfect economical reach rod everytime!

### ORDERING INFORMATION TABLE

**Reach rod diameter: A**

**Machined flats lengths: B**  
Required to fit your handwheel.

**Square or Taper dimensions: Bottom End: C**

**Taper dimension: Top End: D**

Simply verify the dimensions on the above drawings and provide the dimension represented by the blanks above to expedite accurate completion of your order.



## HEAVY DUTY HANDWHEELS

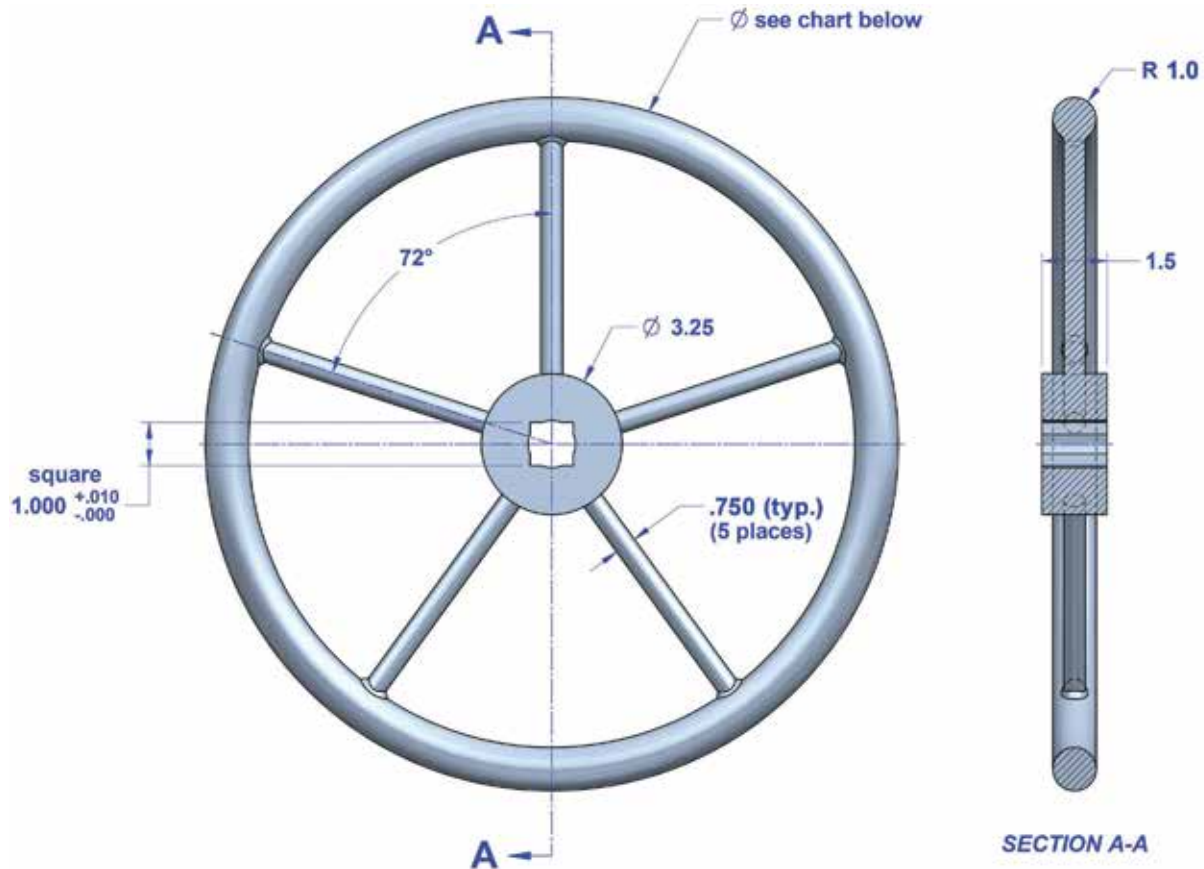

ERL's Heavy Duty Handwheels feature a stainless steel hub and spokes surrounded by a solid 1" diameter rolled 300 Series Stainless Steel ring. ERL's standard hub has a 1" square broached hole that is a full 1-1/2" thick for extra strength.

### Standard Sizes

ERL Part No.#	Diameter
HW-1-12	12" Diameter
HW-1-14	14" Diameter
HW-1 - 16	16" Diameter
HW-1 - 18	18" Diameter
HW-1 - 20	20" Diameter

## ROD-TO-ROD COUPLERS

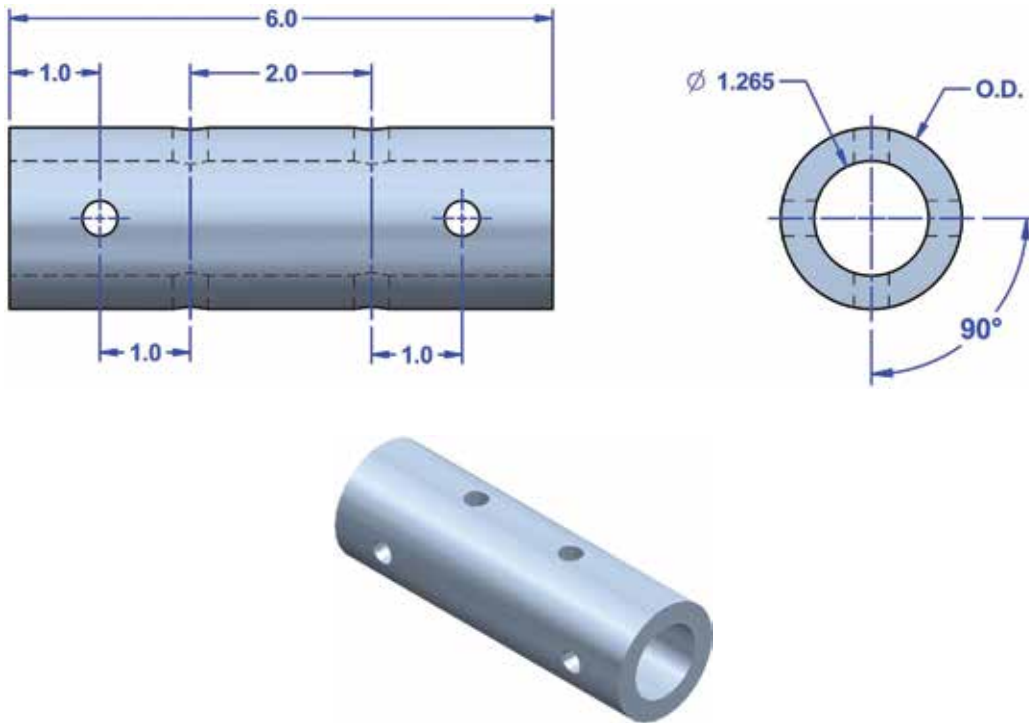

- ERL Rod-to-Rod Couplings are machined from solid stainless steel bar stock (series 300) to ensure a smooth fit with the Reach Rod's outside diameter. Standard Couplings are 6" long and are drilled in four places to accept .375" dia. Grade 8 bolts. The Reach Rod is matched drilled at assembly to the Coupling's bolt pattern. ERL can offer a solid style Coupling that can also be welded to the Reach Rod on either or both ends, if desired. Sizes: 3/4" to 2". Custom applications available.

**SHAFT HANGERS**

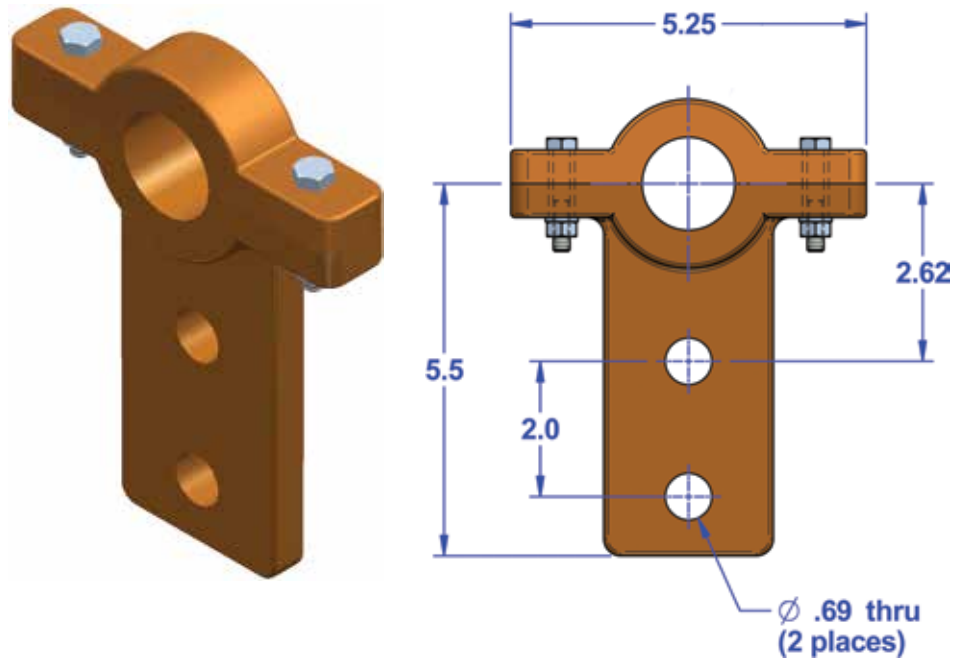

- ERL Shaft Hangers provide added support along the length of the reach rod.
- SHAFT HANGERS ARE AVAILABLE IN 303SS, 316SS, and Bronze.
- The Shaft Hangers are designed with 1/16" clearance between the reach rod and shaft hanger bore.

**ORDERING INFORMATION TABLE**

Reach Rod Diamter	3/4"	1"	1-1/4"	1-1/2"	1-5/8"	1-3/4"	2"
303 Stainless Steel Shaft Hanger	SHA1-A	SHA1-C	SHA1-E	SHA1-G	SHA1-H	SHA1-I	SHA1-K
316 Stainless Shaft Hanger	SHA2-A	SHA2-C	SHA2-E	SHA2-G	SHA2-H	SHA2-I	SHA2-K
Bronze Shaft Hanger	SHA3-A	SHA3-C	SHA3-E	SHA3-G	SHA3-H	SHA3-I	SHA3-K



## YOKES STRAIGHT SQUARE

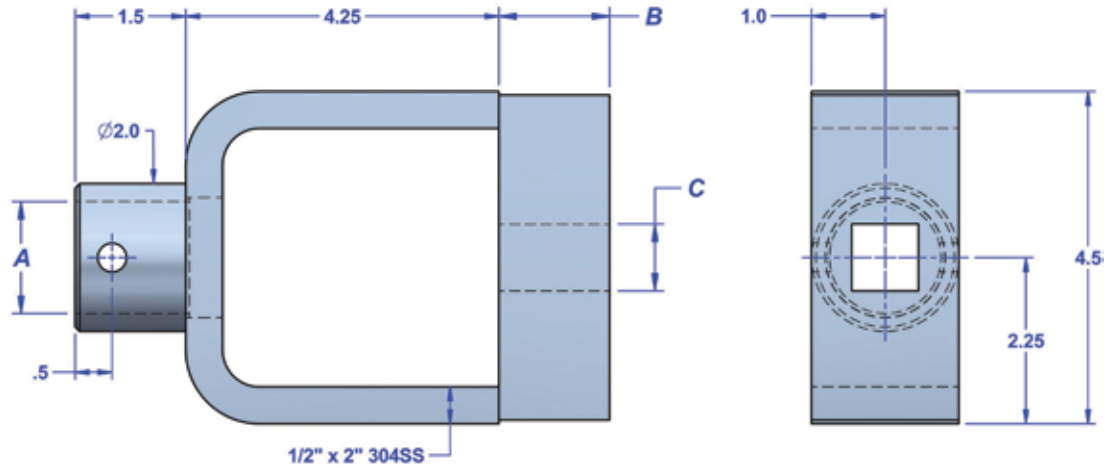
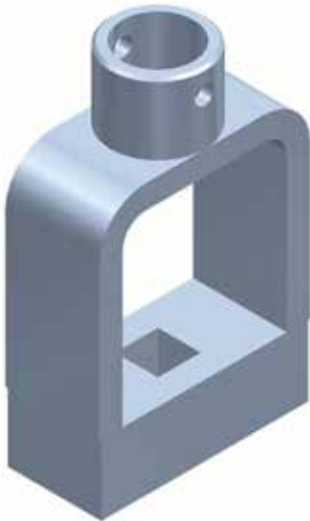

ORDERING INFORMATION TABLE
ROD DIAMETER: A =
DEPTH: B =
SQUARE DIMENSION: C =

**• EASY INSTALLATION**

Machined to easily fit your Reach Rod and Cargo Valve stem. When ordering, provide the Reach Rod diameter and the Valve Stem mounting dimensions as called out with the letters "A", "B" and "C" in the above drawing.

**• HEAVY DUTY CONSTRUCTION**

ERL Yokes are manufactured from heavy 300 series, corrosion resistant stainless steel for totally trouble-free service.

**• SLIP YOKE**

A slip yoke is available to allow for thermal and structural expansion and contraction to minimize wear and tear on the valve from undesired forces.

**ORDERING INFORMATION TABLE**

Reach Rod Diamter	3/4"	1"	1-1/4"	1-1/2"	1-5/8"	1-3/4"
Standard Part No.	YOKE-SS-3/4	YOKE-SS-1	YOKE-SS-1-1/4	YOKE-SS-1-1/2	YOKE-SS-1-5/8	YOKE-SS-1-3/4
4" Slip Style Yoke Part No. (DWG# 325Y149B)	YOKE-SLIP-3/4	YOKE-SLIP-1	YOKE-SLIP-1-1/4	YOKE-SLIP-1-1/2	YOKE-SLIP-1-5/8	YOKE-SLIP-1-3/4
9" Slip Style Yoke Part No. (DWG# 051AA076P)	YOKE-SLIP-FLAT STYLE-3/4	YOKE-SLIP-FLAT STYLE-1	YOKE-SLIP-FLAT STYLE-1-1/4	YOKE-SLIP-FLAT STYLE-1-1/2	YOKE-SLIP-FLAT STYLE-1-5/8	YOKE-SLIP-FLAT STYLE-1-3/4

## YOKES TAPERED SQUARE

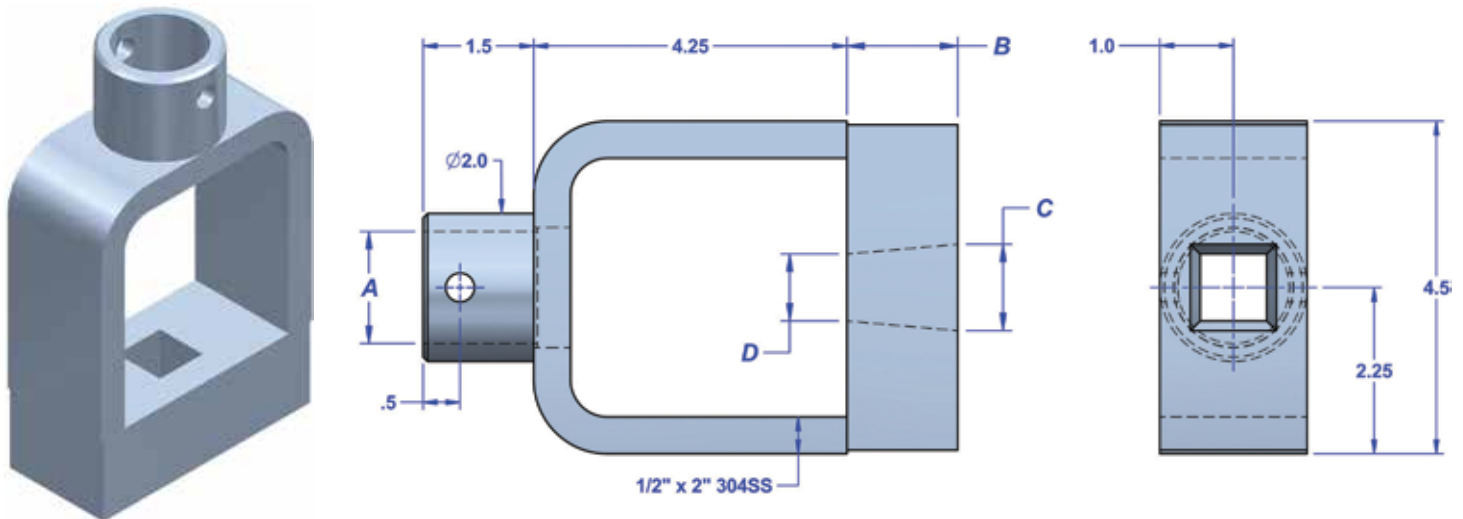

ERL's heavy stainless steel rod-to-valve connection yoke is the easiest and most economical way to connect the lower end of the Reach Rod to the Cargo Control Valve. ERL machines, from the dimensions you supply, the lower end of the Yoke to match your Cargo Control Valve stem. The upper end of the Yoke is also machined and is designed to be either welded or bolted to the lower end of the Reach Rod.

**ERL Square TaperYokes are available in the following sizes to fit the lower end of standard ERL Reach Rods.**

<b>YOKE P/N</b>	<b>Dia. Reach Rod A</b>	<b>Taper Depth B</b>	<b>Bottom Square C</b>	<b>Top Square D</b>
YOKE-SS-TAPERED-3/4	0.75"			
YOKE-SS-TAPERED-1	1.0"			
YOKE-SS-TAPERED-1-1/4	1.25"			
YOKE-SS-TAPERED-1-1/2	1.50"			
YOKE-SS-TAPERED-1-5/8	1.625"			
YOKE-SS-TAPERED-1-3/4				

Specify the drawing call-out dimensions "B", "C" & "D" above for proper fit of the lower end of the Yoke to the Cargo Valve Stem.

## REGULATORY SIGNS



Emergency Shutdown sign and Frame mounted next to Warning Dangerous Cargo Sign and Frame.



Emergency Shutdown Sign and Frame mounted next to main vapor line.



Warning Dangerous Cargo Sign with Frame containing CGS sign on top CIC sign and NOT sign on side mounted next to Danger - Benzene Sign with Frame.

## REGULATORY SIGN PROGRAM FOR TANK BARGES

### DANGEROUS CARGO SIGN

Standard Model DCA-001 shown here with required Cargo Sign, Cargo Information Card and Emergency Notification Signs. While these three smaller signs are USCG required, they are not included with the DCA-001 so that you may order the exact cargo signs you need separately. The basic DCA-001 includes the mounting platforms for these signs.



- **ALL SIGNS MEET OR EXCEED USCG REGULATIONS**

We have carefully studied all of the applicable USCG regulations so that you won't have to worry about whether or not your signs meet the specs. Your barge is not going to be "grounded" because of an incorrect or missing sign.

- **TOP QUALITY MATERIALS AND CONSTRUCTION**

ERL regulatory signs are designed for the harsh working environment encountered by barges year after year and season after season. Frames are made from 300 series stainless steel, signs are aluminum and mounting hardware is stainless steel. The best exterior rated finishes are used and all components are completely finished before assembly.

- **YOUR MOST COST EFFECTIVE WAY TO COMPLY WITH USCG REGULATIONS**

ERL signs are your best value because we manufacture our signs in quantities sufficient to keep production costs low and quality high.

- **STANDARDIZED SIGNAGE SYSTEM**

Standardized sizes for frames and signs means savings to you years from now when you have to replace damaged or obsolete signs. Replacing or changing signs is quick, easy and hassle free. Expensive "field-fitting" is a thing of the past.

- **THE LARGEST INVENTORY IN THE INDUSTRY**

We have the signs you need in stock ready for shipment. All signs are UPS shippable and can be express shipped, in most instances, the same day you order.

## DCA-001 & BNZ-001

DCA-001 and BNZ-001 signs are built to last with all the features you want in one ready to install unit. Each unit features an easily collapsible, low-profile stainless steel design. Includes: 2 sided 29" x 42" "Warning - Dangerous Cargo" (black lettering on white background) sign, bright red pennant with lantern hook and bolt-on platforms for auxiliary signs. NOTE: CHRIS code signs (CCS-xxx), Cargo Signs (CGS-xxx) and Emergency Notification Sign (NOT-001) are not included and must be ordered separately. Mounting feet are designed to bolt-down or weld-down and can be installed to allow sign to lay down to port or to starboard. Assembly booklet/parts list is included. These signs are UPS shippable and the sturdy packaging means that you can keep extra units in inventory for emergencies without fear of damage.

- **Simple design allows sign to be laid down in seconds and without tools.**
- **100% Stainless Steel Hardware.**
- **Lantern hook is built on to pennant pole.**
- **Easy assembly.**
- **Tough polyester powder coated finish.**
- **Weld-down or bolt-down mounting feet.**



### RED PENNANT AND POLE

Red Pennant with tough red polyester powder coated finish (both sides). Includes pre-drilled mounting holes in the pole, lantern hook and stainless steel mounting hardware.



**CARGO VALVE LOCATION SIGNS**

Although these signs are only 4" x 6", they can be read from more than 40 feet away. Standard signs are available in three series for cargo valves 1 thru 8 (Part numbers CRV-001 thru CRV-008), 1P thru 4P for port side cargo valves (Part numbers CRV-01P thru CRV-04P) and 1S thru 4S for starboard side cargo valves (CRV-01S thru CRV-04S). All signs have a one sided imprint with black letters on a yellow background and are pre-drilled with four 1/4" holes for easy mounting.



**BARGE CONNECTOR SIGN BCS-001**

The BCS-001 is designed to identify the location of the barge overfill alarm system electrical connector. It is 7" x 11" and contains all information required including a space for the system inductance rating in millihenrys and the system capacitance in microfarads. Please furnish this information when ordering and allow 2-3 weeks for delivery. This is a two-sided imprint with black letters on a white background.

**CARGO SIGN - CGS-XXX**



Made from powder-coated aluminum. These signs are 4" x 32" with the cargo name screen-printed in 2" high letters and the three-letter CHRIS code in 3" high letters. Designed to attach with stainless steel split rings to the top-mounted auxilliary sign platform on our DCA-001. These signs are one color (black letters on white background) with imprint on both sides. SUGGESTION: When ordering signs for four or more cargos for the same barge - order one extra sign and we can preassemble your cargo signs in sets that can be conveniently flipped so that they display the same cargo designator from either port or starboard (this is accomplished by leaving one side of two of the signs blank, thus necessitating one additional sign). We stock the 30 most popular cargo signs and are adding more all the time. If you are requesting a cargo designator that we do not have in stock, please allow 2-3 weeks for delivery. To order - fill in the 3 letter CHRIS code designator after "CGS-" in the part number and use CGS-xxx for your extra sign, if ordering pre-assembled sets.



**CARGO INFORMATION CARD  
CIC-XXX**

7" x 11" powder-coated aluminum. Designed to securely attach with stainless steel rings to the side-mounted auxilliary sign platform on our DCA-001. These signs are printed two colors (white background with black letters and bright red border highlights) imprinted on both sides. SUGGESTION: When ordering signs for four or more cargos for the same barge-order one extra sign and we can pre-assemble your cargo information cards into sets that can be conveniently flipped so that they read the same CHRIS Code information from either port or starboard. We stock the 30 most popular cargo signs and are adding more all the time. If you are requesting a cargo designator that we do not have in stock, please allow 2-3 weeks for delivery. To order - fill in the 3 letter CHRIS Code designator after the "CIC-" in the part number.

**FILL/SUCTION VALVE SIGN**



**FSV-001**

**PUMP BLOCK VALVE SIGN**

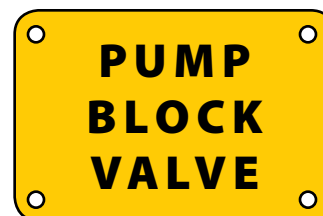

**PBV-001**

7" X 11" Black letters on Yellow background, 1 Sided. Pre-drilled for easy mounting.

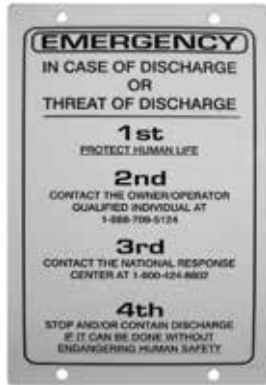

**EMERGENCY NOTIFICATION SIGN  
NOT-001**

This sign is custom made for your company's barges on powder coated aluminum for optimum durability. The standard format is 7" X 11" one color (black letters on white background) and screened two sides with predrilled mounting holes. However, we can add a second color, or your company logo for a nominal charge.

**ULLAGE GAGE  
LOCATION SIGN - ULG-001**

Formed with a 1-1/2" lip on the bottom (pre-drilled with two 1/4" holes) for easy and quick mounting. The information area is 9-1/2" x 7" and is a two sided imprint with blue letters on a white background.



**EMERGENCY SHUTDOWN SIGNS  
EMS-002**

Made from aluminum with tough baked-on bright red enamel. EMS-002 is a 14" square sign printed on two sides and pre-drilled with 1/4" holes at each corner.



**EMF-001**

This rugged frame is made to hold the EMS-002 and weld or bolt securely to your deck. Stainless steel sign mounting and frame assembly hardware is included.



### DCA-001 & BNZ-001 SIGN MOUNTING DIMENSIONS

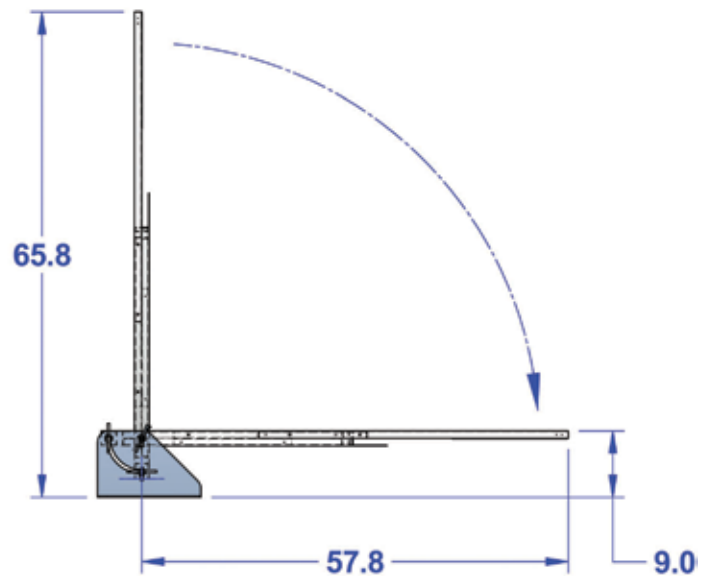
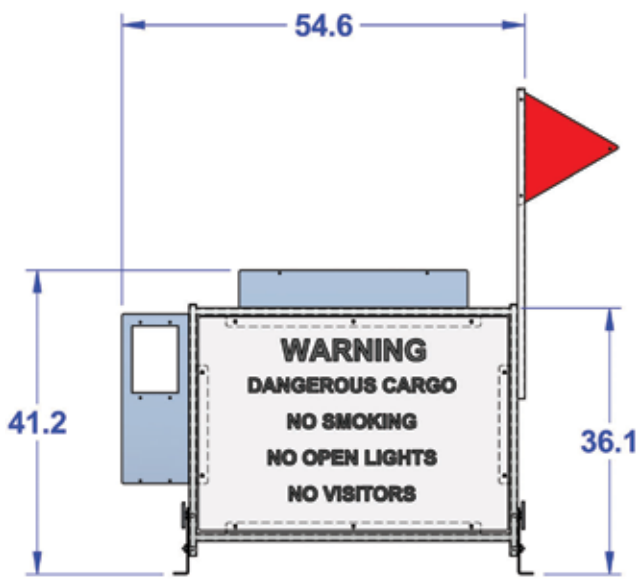
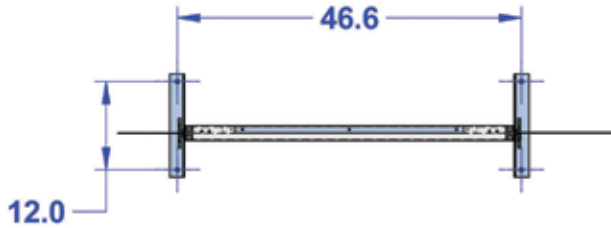



## **REGULATORY SIGN PROGRAM - ORDERING INFORMATION**

<b>PART NUMBER</b>	<b>DESCRIPTION</b>	<b>All Items UPS Shippable</b>
DCA-001	"Dangerous Cargo" Sign Package - Includes: Sign, Frame, Red Pennant (with pole), Mounting Platforms for Cargo Information Cards, Emergency Notification Sign, Cargo Signs and Mounting Feet. (CIC-xxx. CGS-xxx and NOT-001 not included - order separately).	
DCA-002	"Dangerous Cargo" - SIGN ONLY - 2 sided, 1 color. Black letters on white background (29" x 42" aluminum) pre-drilled.	
BNZ-001	"Danger - Benzene" Sign Package includes Sign, Frame, and Mounting Feet. Black enamel finish is standard on sign frame. Optional galvanized finish available.	
BNZ-002	"Danger - Benzene" - SIGN ONLY - 2 sided, 1 Color. Black letters on white background (29" x 42" aluminum) pre-drilled.	
PNT-001	Red pennant with mounting pole & lantern hook.	
CGS-xxx	Cargo Signs - 4" x 32", 2 sided, 1 color. Black letters on white background. Pre-drilled (specify three letter CHRIS Code).	
CIC-xxx	Cargo Information Cards - 7" x 11", 2 sided, 2 colors. Red & Black on White background, pre-drilled (specify three letter CHRIS Code).	
ULG-001	"Ullage Gauge Here" Sign - 7" x 11", Pre-formed mounting lip and pre-drilled. 2 sided, 1 color. White letters on blue background.	
CRV-xxx	"Cargo Valve #_" Signs - 4" x 6", 1 sided - 1 Color. Black on Yellow, If applicable, specify cargo tank number and port or starboard.	
EMS-002	"Emergency Shutdown" Sign - 14" x 14" square layout, 2 sided, 1 color. White letters on red, background. Pre-drilled.	
EMF-001	Mounting frame for EMS-002, with mounting feet. Black painted finish standard.	
NOT-001	"In Case of Emergency" - 7" x 11", 2 sided, 1 color. Black letters on white background. Pre-drilled. This is a custom sign - please allow 3-4 weeks for delivery. Set up charge applied for quantities less than 25 signs.	
BCS-001	"Barge Connector" Sign - 7" x 11", 2 sided, 1 color. Blue letters on white. SPECIFY: System Inductance in Millihenrys and System Capacitance in Microfarads. Allow 2-3 weeks for delivery.	
PBV-001	"Pump Block Valve" - 7" x 11", 1 Sided, 1 color. Blue letters on Yellow.	
FSV-001	"Fill/Suction Valve" - 7" x 11", 1 Sided, 1 color. Black letters on Yellow.	

## MARINE CAM HANDLE SCUPPER PLUG



- **FULL REGULATORY COMPLIANCE**

ERL's Scupper Plugs help to ensure your barge meets regulatory compliance of 33 CFR 155.205 – Discharge Removal Equipment for Vessels. Regulations requires that oil tankers and offshore oil barges with an overall length of 400 feet or more must carry appropriate equipment and supplies for the containment and removal of an on-deck oil cargo spills of at least 12 barrels.

- **MATERIALS & OPERATIONS**

All ERL Scupper Plug are constructed from forged EPDM material allowing for superior quality as well as extended product life while in the field. Each Scupper plug comes standard with a bronze hex nut and stainless steel lanyard for to ensure a secure fit. ERL can also offer a bronze wing nut if preferred. For in stock available sizes please refer to the item list. ERL can offer other sizes if desired.

- **SIMPLIFIED OPERATION**

The ERL Cam Handle Scupper plug makes the scupper plug seal a one step operation. Flip the handle 180 degrees from open to closed and the plug provides a tight seal inside the pipe.

- **ADJUSTABLE**

The ERL Cam Handle Scupper plug is adjustable to fit various schedule pipes inside diameters. For use with nominal 1.875", 2.0", and 2.2" Scupper Plugs.

## LIP SEAL STUFFING BOX



- **100% STAINLESS STEEL CONSTRUCTION**

ERL's SUPER SEAL™ Reach Rod Stuffing Box is completely constructed of 300 series stainless steel. Produced on computer controlled machines to accurately control dimensional quality, the body of the stuffing box is a massive 5" diameter to prevent deformation of the bore from the heat of welding during installation.

- **VAPOR TIGHT PERFORMANCE**

Teflon™ lip seals are designed to fit perfectly in each size Stuffing Box forming an effective vapor tight seal preventing fugitive emissions. The "V" shaped Teflon™ seals are compressed with a stainless steel compression spring. A bronze bushing with impregnated PTFE provides support for the shaft while minimizing friction and wear. For best long term performance the reach rod should be turned, ground and polished stainless steel.

- **EASY INSTALLATION**

ERL stocks the most popular size stuffing boxes, as listed, other sizes are produced as requested. Standard Stuffing Boxes can be flush mounted, a counterbore also permits mounting on a 2.5", 3", or 4" pipe. Other size counterbores, including threaded counterbores, are produced as requested.

- **AVAILABLE VALVE POSITION INDICATOR**

All size Stuffing Boxes are designed to easily accommodate the ERL Valve Position Indicator. Save time and money by installing the Valve Position Indicator and Stuffing Box at the same time. Additionally ERL can provide Handwheels, Stem Adapters, Reach Rods, Couplings and Yokes.

## U-JOINT



- **MARINE GRADE MATERIALS**

Every component of the ERL U-Joint utilizes 300 series stainless steel. To further prevent corrosion or galling the stainless steel pins are coated with a Calico Dry Film Lubricant. This is the same coating used on racing engine bearings and military applications. This gives you long life and great value.

- **PRECISION MANUFACTURING**

Manufactured using state of the art CNC machines that hold each part to less than .002" tolerance. This ensures each and every part is of the highest quality.

- **MULTIPLE APPLICATIONS**

The ERL U Joints are used between upper and lower reach rods for valve actuation and between lower reach rods and yokes.

- **450FT LB TORQUE RATING**

- **SIZES AVAILABLE:**

3/4", 1", 1-1/4", 1-1/2" and 1-3/4". Custom applications available.



## DECK STAND – LASER ALIGNMENT TOOL KIT INSTALLATION

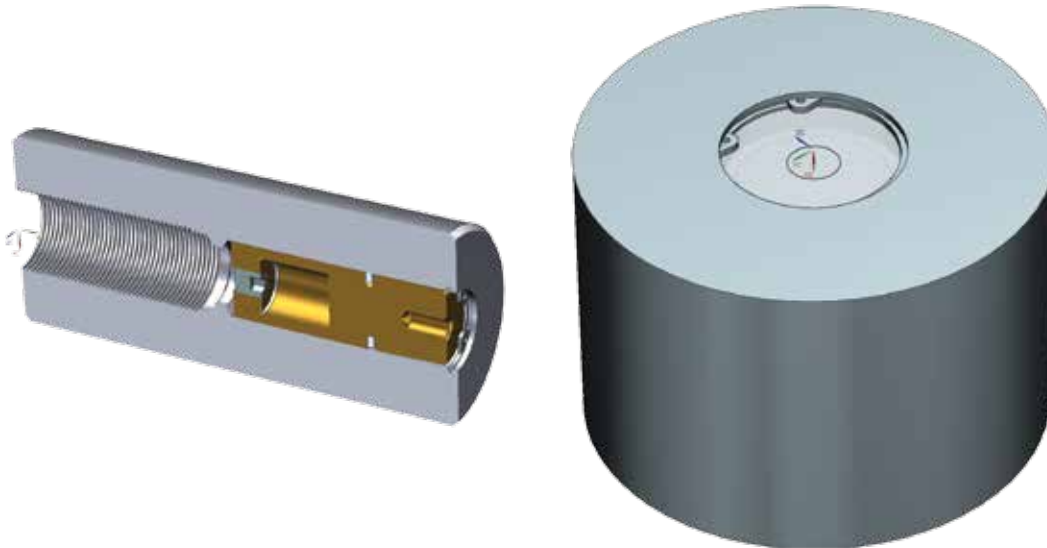

- **SIMPLE DESIGN**

The ERL Laser Alignment tool for deckstand gives the shipyard a simple yet sophisticated tool to make deckstand installation a breeze.

- **MARINE GRADE MATERIALS**

ERL utilizes 300 series stainless and pyrex glass for the housing and sight glass. The laser is inside a bronze housing for durability.

- **EFFECTIVE TOOL**

The most common valve actuation issue is misalignment during the installation. The ERL laser alignment tool ensures that the deckstand is welded in exactly the right location the first time.

## STUFFING BOX – LASER ALIGNMENT TOOL KIT INSTALLATION



- **SIMPLE DESIGN**

The ERL Laser Alignment tool for stuffing box gives the shipyard a simple yet sophisticated tool to make stuffing box installation a breeze.

- **MARINE GRADE MATERIALS**

ERL utilizes 300 series stainless and pyrex glass for the housing and sight glass. The laser is inside a bronze housing for durability.

- **EFFECTIVE TOOL**

The most common valve actuation issue is misalignment during the installation. The ERL laser alignment tool ensures that the stuffing box is welded in exactly the right location the first time.



## PRESSURE/VACUUM VIBRAGAUGE

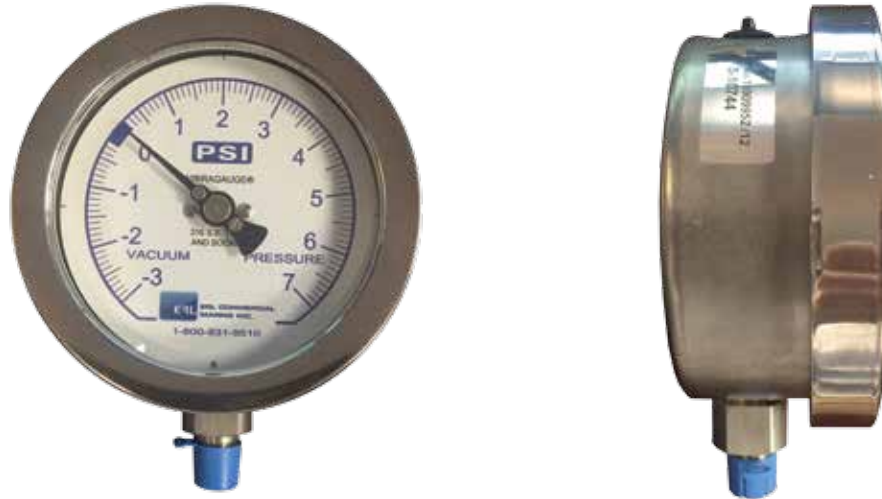

- **VIBRAGAUGE**

The dry gauge features a needle with dampened heavy duty movement mechanism to eliminate pointer flutter in high vibration environments. This increases the life of the gauge, makes the gauge easier to read, and eliminates the potential for fluid to leak from the gauge. Gauge features a white painted aluminum dial, black printed figures, and black anodized aluminum pointer.

- **STANDARD RANGES**

- -4 to 4 PSI
- -3 to 7 PSI
- 0-200 PSI
- Other Ranges Available

- **HEAVY DUTY STAINLESS STEEL CONSTRUCTION**

The heavy gauge 316SS housing is intended for rugged outdoor use. ERL Pressure Gauges have all stainless steel cases and safety glass lens. Available in 1/4" or 1/2" NPT attachment fittings and 4" Dial Standard.

- **±0.5% ACCURACY**

A large easy-to-read dial is calibrated to ±0.5% full scale accuracy. ERL can prepare a Certificate of Accuracy, should you require one, for a nominal fee. Recertification, calibration and repair services are also available. For accuracy and proper operation, all Pressure Gauges must be mounted in the vertical position and the gasket under the vent cap must be removed to allow the gauge to breathe.

- **DRY GAUGE**

The gauge needle is dampened heavy duty movement mechanism to extend the service life of the gauge and eliminates pointer flutter. Gauge features a white painted aluminum dial, black printed figures and black anodized aluminum pointer.



**SECTION  
06**

# FABRICATION PRODUCTS

**NEW!**



**Overflow Tank - Diesel Engine Radiator**

pg 148

**NEW!**



**Dry Box - Pipe Mount**

pg 149

**NEW!**



**Cargo Cleaning Diffuser**

pg 150

**NEW!**

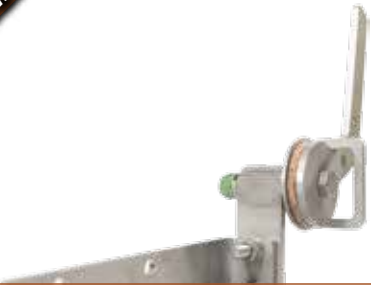

**Throttle Control Handle**

pg 151



**Dry Box**

pg 152



**Cargo Pump Catch Can**

pg 153



**Drip Pans**

pg 154



**Vent Stacks**

pg 155



**Ladders**

pg 156



**Barge Fuel Tanks**

pg 159



**Barge Spill Kit Rack**

pg 160



**Marine Scupper Plug**

pg 161

**SECTION  
06**

**FABRICATION PRODUCTS**



**Document Boxes**

**pg 162**



**Fire Extinguisher Holders**

**pg 163**



**Hose Rack**

**pg 164**



**Air Box Drain Canister**

**pg 165**



**Telescopic Peep Light**

**pg 166**



**Tankerman's Shed**

**pg 167**

## OVERFLOW TANK – DIESEL ENGINE RADIATOR



- **VISUAL INDICATION AT A GLANCE**

The Overflow Tank gives the tankerman visual indication of tank level at the top of the tank. The indicator is sealed inside a Pyrex glass that will not deteriorate over time. The same glass is used in our best selling SGM Sight Glass series.

- **MARINE GRADE CONSTRUCTION AND EASY INSTALLATION**

Constructed entirely from 304 stainless steel for extended life, the overflow tank is easily installed during new construction or as a retro-fit installation to an existing barge. The overflow tank comes complete with hoses, fittings, and installation instructions.

- **GENEROUS CAPACITY FOR EVERY TEMPERATURE**

With tank dimensions of 11"x 6"x 4.5", the overflow tank will hold 1.3 gallons. This allows for a significant temperature rise of coolant without spilling on the deck! A great way to prevent spills and satisfy USCG regulations.



## **DRY BOX – PIPE MOUNT**



- **EASILY MOUNTED ON AN EXISTING 6" OR 8" PIPE**
- **INCREASE STORAGE ABILITY**  
Dry Box Increase Storage on the deck of the barge for a wide range of uses: Spare Parts, Tools, Specialty Equipment, etc.
- **100% STAINLESS STEEL CONSTRUCTION**  
Constructed from 300 series Stainless Steel.
- **SECURE**  
Available with a Latch for a padlock to ensure contents are available when you need them.
- **GENEROUS SIZE**  
The box is sized at 18" wide by 18" tall by 36" long to easily accommodate a large number of tools, parts, and equipment.

## CARGO CLEANING DIFFUSER



- **COMPLETE ½" THICK, 304SS CONSTRUCTION**  
All pieces of the diffuser fabricated from ½" thick and Schedule 40 304SS.
- **6" 150 PSI FLANGE MOUNT**
- **DESIGNED SYSTEM**  
Mounted inside the cargo tank and connected to a designed system to circulate product using the cargo pump.
- **TANK RECIRCULATION**  
When product is circulated with the main cargo pump, diffuser emits flow along the bottom of the tank to suspend any solids formed during transport.



## **THROTTLE CONTROL HANDLE**

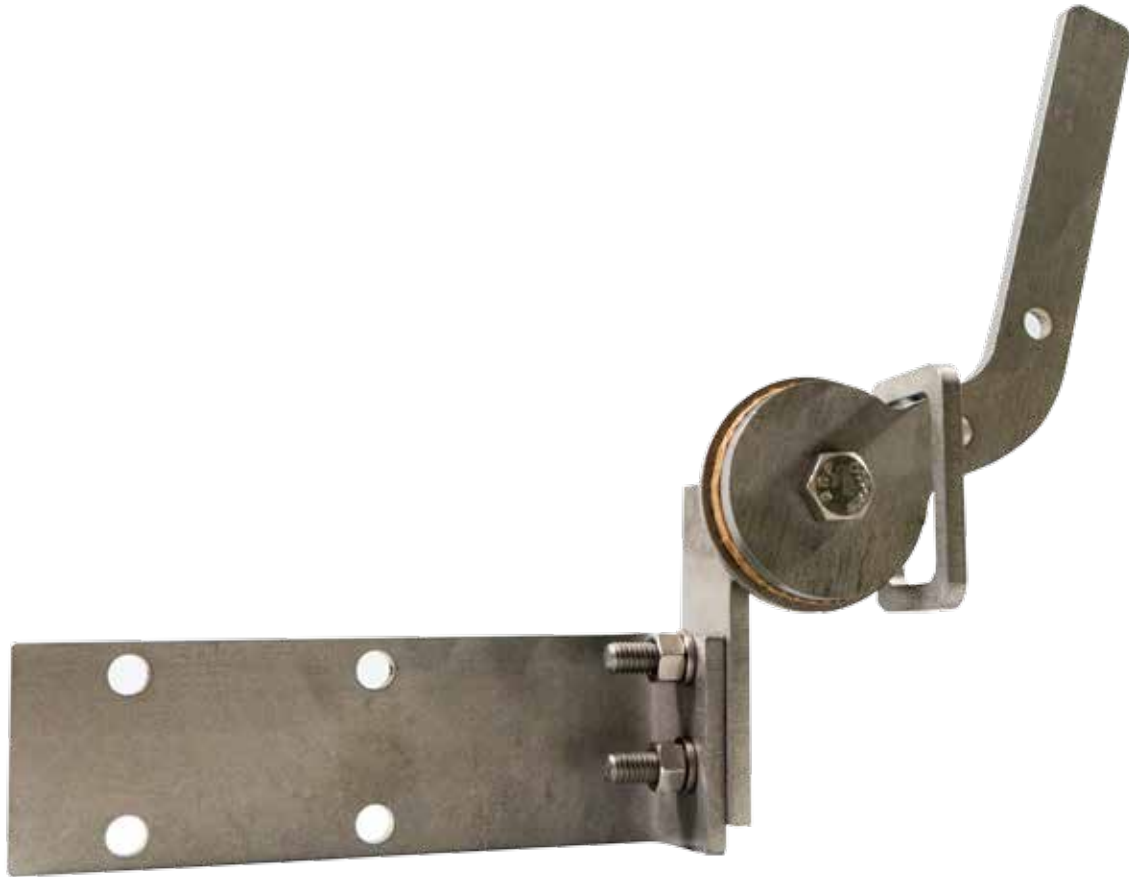

- **HORIZONTAL OR VERTICAL ORIENTATION AVAILABLE**
- **REPLACEMENT THROTTLE CONTROL HANDLES**  
Available for Hydraulic and Mechanical governor application.
- **100% STAINLESS STEEL CONSTRUCTION**  
Fully fabricated from 304 Stainless Steel.
- **COMPLETE ASSEMBLY**  
Provided with Stainless Steel mounting bracket and Linkage with Plated Steel Ball Joints.

## DRY BOX



- **INCREASE STORAGE ABILITY**  
Dry Box Increase Storage on the deck of the barge for a wide range of uses: Spare Parts, Tools, Specialty Equipment, etc.
- **100% STAINLESS STEEL CONSTRUCTION**  
Constructed from 300 series Stainless Steel.
- **SECURE**  
Available with a latch for a padlock to ensure contents are available when you need them.
- **CUSTOMIZABLE**  
Dry Boxes are fabricated to the customers specification. External dimensions and internal divider options are all customizable.



## CARGO PUMP CATCH CAN



- **INCREASE STORAGE ABILITY**  
Gain an additional 1 gallon of backup product storage capacity from the cargo pump pollution head.
- **100% STAINLESS STEEL CONSTRUCTION**  
Constructed from 300 series Stainless Steel.
- **BOLT-ON DESIGN**  
Available as a bolt-on design to fit a wide range of cargo pumping systems. The can is piped inline from the pollution head to the pump well suction valve.
- **LIFT TOP**  
Simple lift top design allows Catch Can contents to be checked easily and allows for easy cleaning.



### DRIP PANS



- **FULL REGULATORY COMPLIANCE**

ERL Drip Pans satisfies 33 CFR 155.310 for containment of Oil and Hazardous material cargo discharge.

- **HEAVY DUTY CONSTRUCTION**

All ERL Drip Pans can be custom made to fit your requirements. Drip pan covers are typically constructed out of 300 series stainless steel and the grating and body can be constructed out of carbon or stainless steel depending on customer preference.

ERL can supply customized drip pan covers and grating. Covers are typically constructed from 300 series stainless steel and grating can be stainless steel, carbon steel, or galvanized. All that is needed for ordering is customer drip pan dimensions and style of cover (one piece, two piece, or sliding style construction).



**Ordering Dimensions:**

- Cover Material \_\_\_\_\_
- Grating Material \_\_\_\_\_
- Body Material \_\_\_\_\_
- Number of Barrels \_\_\_\_\_ bbl
- Height \_\_\_\_\_ in
- Length \_\_\_\_\_ in
- Depth \_\_\_\_\_ in
- Leg Height \_\_\_\_\_ in
- Coupling Size \_\_\_\_\_ in

## VENT STACK



Top section of Vent Stack containing Flame Screen

Remove the 1/2" Nut at the top to access the replaceable flame screen

- **FULL REGULATORY COMPLIANCE**

ERL Vent Stacks satisfies the requirements of 46 CFR Subpart 32.55 – Ventilation and Venting and includes a 30 X 30 316SS mesh Flame Screen which complies with U.S. Coast Guard Regulations 46 CFR part 39, Paragraph 39.20-3 (a).

- **100% STAINLESS STEEL**

All ERL Vent Stacks are constructed from 304 Sch 10 stainless steel ensuring extended service life and a reduced need for maintenance. The top of the Vent Stack contains a replaceable 30 X 30 316SS Mesh allowing for optimum resistance to flame propagation.

- **MAINTENANCE AND OPTIONS**

Since the ERL Vent Stacks are constructed from 300 series stainless steel it reduces the need for maintenance and the top section of the Vent Stack is easily disassembled for complete inspection and replacement of the internal flame screen. ERL offers swivel, ridged mount or tee mount and the body can be produced from either 8" or 10" 304 sch 10 stainless steel.



ERL Vent Stack Collapsible - mounted on swivel flange.

## LADDERS



Standard 3 Rung Ladder



Stainless Steel  
Ladder - 5 rung

- **100% STAINLESS STEEL**

ERL's Barge Ladders are manufactured from 300 series stainless steel ensuring sturdy construction as well as extended life of the product while in the field. ERL's standard Ladder is a 3 rung ladder with a 45° degree angle towards the top with steps spaced 12" apart.

- **MATERIALS & MANUFACTURING**

All ERL Ladders are constructed from 1-1/2" 300 series sch 40 stainless steel pipe for the sides and 3/4" 300 series stainless steel square bar for the steps or rungs. ERL's standard 3 rung ladder measures 72" overall height with a 45° degree angle and the distance between brackets measuring 24.5" hole to hole. Supplied with 5/16" thick Mild Steel Mounting Clips.

- **CUSTOMIZE**

ERL can custom build any ladder per customer requirements. Please refer to Ordering dimensions chart for required measurements.



## DECKTOP LADDERS

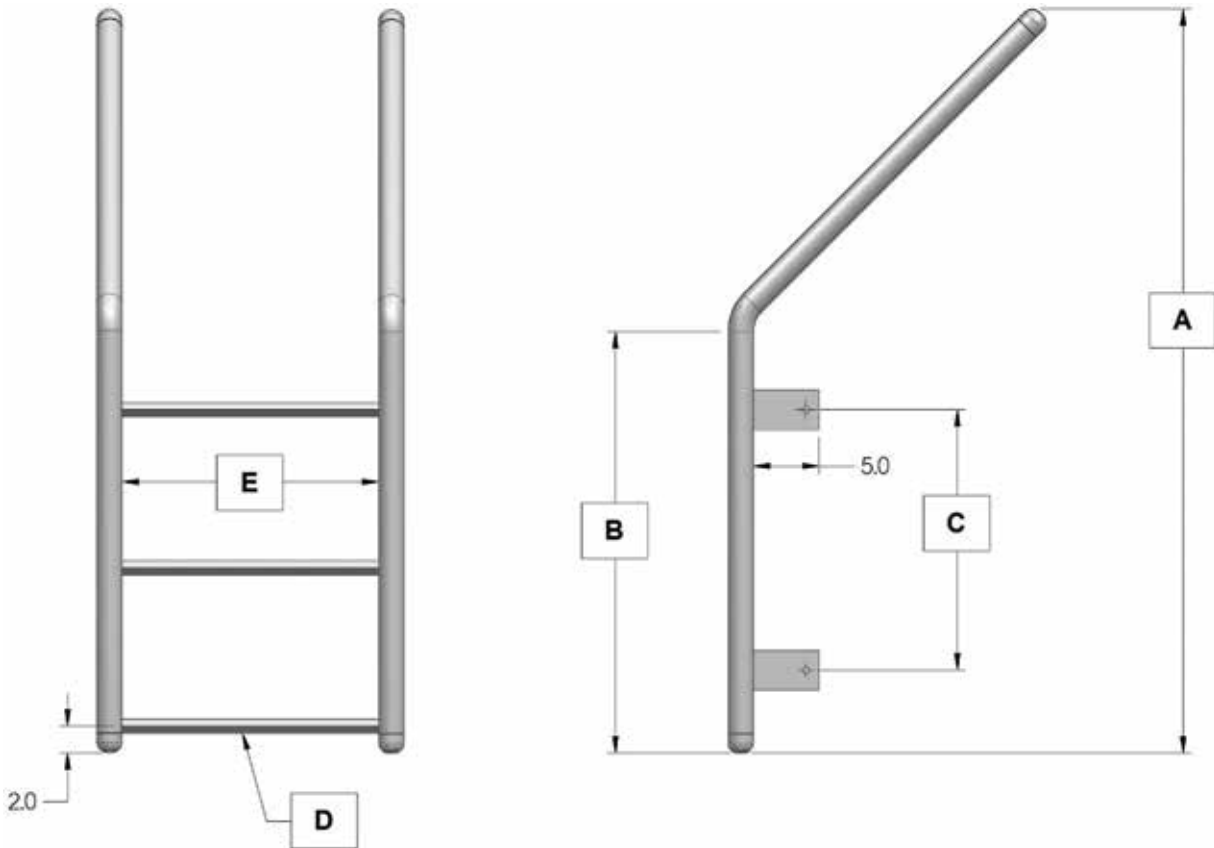

### Ordering Dimensions:

- A = Overall Height
- B = Length of Rail upright section
- C = Hole to Hole distance between brackets  
(standard dim. = 19.75)
- D = Number of Rungs required
- E = Length of Rung

## TANK LADDERS

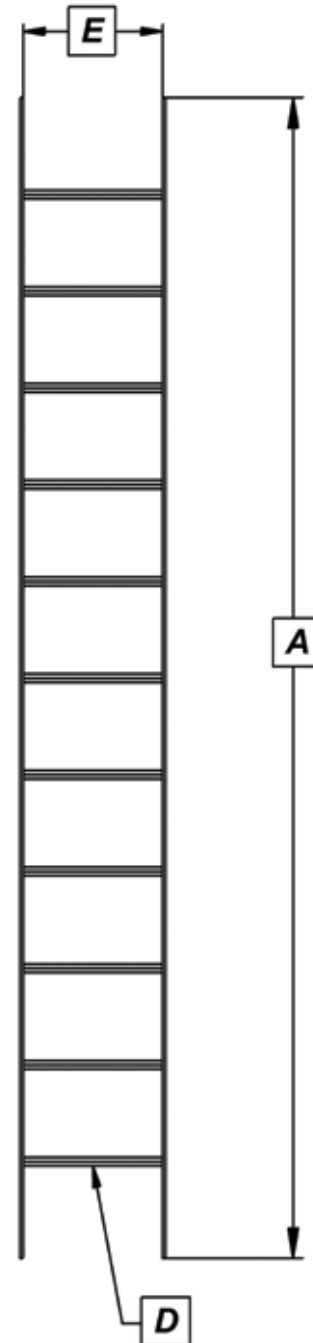
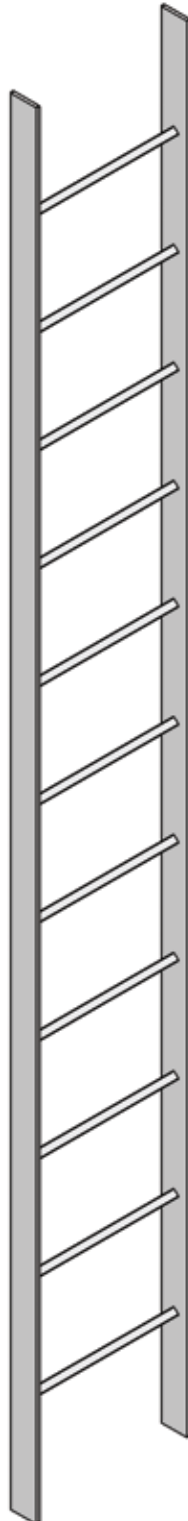

**Ordering Dimensions:**

A = Overall Height  
D = Number of Rungs required  
E = Length of Rung

## FUEL TANKS



500 Gallon Fuel Tank



300 Gallon Fuel Tank

- **FULL REGULATORY COMPLIANCE**

All ERL fuel tanks are constructed from ¼" carbon steel and are welded solid. ERL tests each Fuel Tank prior to shipment. Our standard 300gal Fuel Tank is tested to 6PSI Press. All construction on ERL fuel tanks satisfies 46 CFR 58.50-10 – Diesel Fuel Tanks.

- **MATERIALS & MANUFACTURING**

All ERL 300 Gal Fuel Tanks come standard with a 2" carbon steel Fill pipe, and a 2.5" carbon steel Vent pipe that contains a replaceable 316 stainless steel flame screen. On the top of the Fuel Tank there is an 8" Ullage hatch fitted with an 8"- 316 stainless steel flame screen. On the base of each Fuel Tank ERL adds ½" carbon steel mounting brackets allowing for easy mounting and removal of the tank. There is a stainless Data Tag with serial identification and the date the tank was made.

**NOTE:** Other sizes and all stainless models are available. Please contact ERL with any inquires concerning any additional size requirements.



### BARGE SPILL KIT RACK



- FULL REGULATORY COMPLIANCE**  
 US Department of Transportation 33 CFR part 155 – Discharge Removal Equipment Regulations for Oil Carrying Vessels requires that oil carrying vessels in US waters have oil spill clean up equipment on board for deck spills. ERL's Spill Kit Racks ensure a safe, secure, and easy way to store your Spill Kits on the deck of a barge or boat.
- MATERIALS & MANUFACTURING**  
 ERL Spill Kit Racks are produced from 1/4" X 2" precision laser cut carbon steel material and are formed and welded to ensure a quality product that will last. Each Spill Kit Rack comes complete with a 3/16" galvanized chain containing springs for added tension. Five Safety seals with a breaking force of 6lbs ensure your Spill Kit will be secure and tamper free. Three feet on the base of the Spill Kit Rack allows for easy welding or mounting to any deck surface.
- MATERIAL OPTIONS**  
 Bare Steel, Galvanized Steel, 304 Stainless and a different styled Aluminium model.

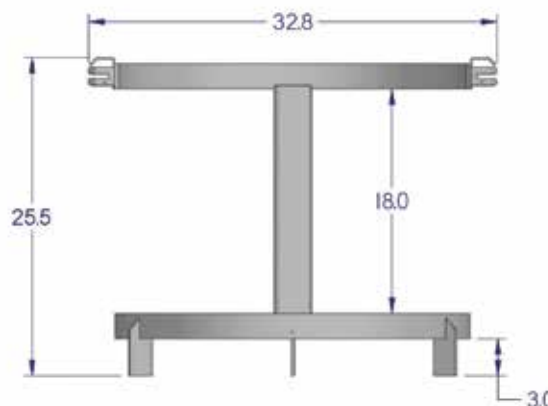
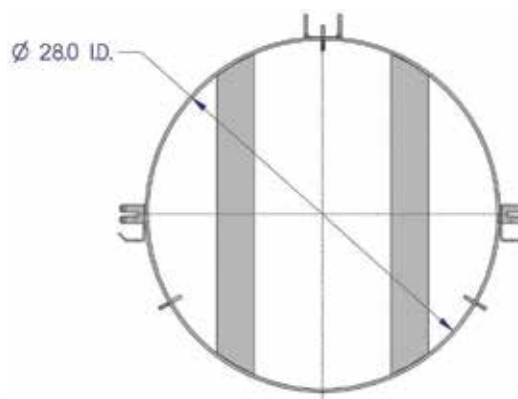



## MARINE SCUPPER PLUG



• **FULL REGULATORY COMPLIANCE**

ERL's Scupper Plugs help to ensure your barge meets regulatory compliance of 33 CFR 155.205 – Discharge Removal Equipment for Vessels. Regulations requires that oil tankers and offshore oil barges with an overall length of 400 feet or more must carry appropriate equipment and supplies for the containment and removal of an on-deck oil cargo spills of at least 12 barrels.

• **MATERIALS & OPERATIONS**

All ERL Scupper Plugs are constructed from forged EPDM material allowing for superior quality as well as extended product life while in the field. Each Scupper plug comes standard with a bronze hex nut and stainless steel lanyard for to ensure a secure fit. ERL can also offer a bronze wing nut if preferred. For in stock available sizes please refer to the item list. ERL can offer other sizes if desired.

• **3/4" TO 4" CURRENTLY AVAILABLE**

<b>Item #</b>	<b>Description</b>
Scupper Plug 1.5-N	1.5" Scupper plug w/Lanyard and Bronze Hex Nut
Scupper Plug 1.875-N	1.875" Scupper plug w/Lanyard and Bronze Hex Nut
Scupper Plug 2.0-N	2.0" Scupper plug w/Lanyard and Bronze Hex Nut
Scupper Plug 2.2-N	2.2" Scupper plug w/Lanyard and Bronze Hex Nut
Scupper Plug 3.0-N	3.0" Scupper plug w/Lanyard and Bronze Hex Nut
Scupper Plug 4.0-N	4.0" Scupper plug w/Lanyard and Bronze Hex Nut

Bronze Wing Nut is offered as an option.



## DOCUMENT BOXES



Side Door Pipe Mount



- **100% STAINLESS STEEL CONSTRUCTION**

ERL Stainless Steel Document box is offered in three different styles. They are constructed from 300 series stainless steel and the Side Door Pipe Mount is weather sealed to ensure protection from all external conditions. ERL welds are passivated so that the box has better resistance to corrosion and looks nicer on your barge.

ERL can also custom design a document box according to your needs.

<b>Standard Sizes</b>	
<b>Top Door</b> (TDPM/TDFR)	<b>Side Door</b> (SDPM)
Material – 304 SS Dimensions – 17.68" X 13.18" X 6.12"	Material – 304 SS Dimensions – 15.56" X 12.87" X 12.06"



Top Door Mount with  
External Mounting Feet



## FIRE EXTINGUISHER HOLDERS



- **100% STAINLESS STEEL CONSTRUCTION**

The ERL Fire Extinguisher Holders allow for safe and secure storage for on deck fire extinguishers. Each holder is constructed from 300 series stainless steel and is welded and bolted allowing for easy usage.

- **EASY TO OPERATE**

A stainless steel latch with rubber pads across the front of the holder ensures a secure fit while allowing for easy access when needed. Across the back of the Holder, ERL has added two formed brackets with rubber pads welded into position which helps to eliminate movement. ERL welds are passivated so that the bracket has better corrosion resistance and looks nicer on your barge.

- **FIRE EXTINGUISHER BRACKET**

ERL also offers an economical all stainless steel fire extinguisher bracket that is manufactured for easy use and mounting.

Item #	Extinguisher Size	Fire Ext. O.D.
FEH #5	10lbs	5"
FEH #7	20lbs	7"
FEH #8	25lbs	8"



Fire  
Extinguisher  
Bracket

## ERL HOSE RACK



- **100% STAINLESS STEEL**

The ERL Standard and W-Style Hose Racks provide a convenient and compact storage system for a collapsible hose. It is constructed from 300 series stainless steel which ensures extended product life as well as durability for continuous use in the field. Both the W-Style and Standard style hose rack comes with mounting brackets which allow the product to pivot out of the way when not in use. All welds are passivated for corrosion resistance and attractive looks.

The ERL Saddle Type Hose Rack provides convenient packaging and storage for all types of hoses. Each ERL Saddle Type Hose Rack is constructed from 300 series stainless steel to ensure extended product life and it's welded construction provides durability for continuous use in the field.

ERL offers four different sizes for the Saddle Type Hose Rack. A rack for 50' or 100' of 1.5" or 2.5" hose. All can be easily mounted by the 2 holes in the support bar. All welds are passivated for corrosion resistance.

**W-STYLE AND  
STANDARD SIZES**

**1.5" Style  
2.5" Style**

\* NOTE: Size refers to the diameter of the hose.



**STANDARD STYLE HOSE RACK**



## AIR BOX DRAIN CANISTER



- **100% STAINLESS STEEL**

ERL offers an Air Box Drain Canister for Detroit Diesel Engines manufactured for collection of engine blow back. The entire unit is constructed out of 300 series stainless steel and all welds are passivated to ensure an attractive product that will withstand the hardships of the barge environment.

- **EASY TO OPERATE**

The ERL Air Box Drain Canister comes complete with stainless steel rubber lined mounting brackets to ensure a safe and secure fit onto any Detroit Diesel Engine. The Canister has two 1/4" NPT threaded fittings allowing for easy attachment of the drain hoses as well as a stainless steel, 3/4" NPT vent and drain to help minimize any pressure or overflow that may build up during operation.

## TELESCOPIC PEEP LIGHT



### • OPERATION & MANUFACTURING

The ERL Telescopic Peep Light is a simple and well designed operational product constructed from 5052 Triangular shaped Alum. Due to the material and construction, it is easily transported and it's rugged design ensures a lasting product life.

The split collar for the 1.72" light is rubber lined to ensure a safe and secure fit. The foot of the Peep Light is 4" dia X .25" thick 5052 Alum. The Peep Light stand contains a tri-style tie down bracket with three .50" holes for anchor ropes. Eyelets along the side are .125" 5052 Alum and are lined with rubber grommets to help protect the cord. ERL also offers a cordless model for a McDermott (NA167436) light powered by 4-AA Batteries.

### • ADJUSTABLE HIEGHTS

Lowest setting = 82.75" tall  
Second setting = 125.50" tall  
Third setting = 165.75" tall  
Highest setting = 201.50" tall





## **TANKERMAN'S SHED**



- **FULLY CONSTRUCTED FROM 5052 ALUMINUM (1/8" & 3/16" THICK)**
- **ALL EXTERNAL SEAMS ARE WELDED**
- **ALL WINDOWS ARE TINTED AND 3 SLIDE OPEN FOR VENTILATION**
- **304 STAINLESS STEEL DOOR HINGE AND LATCHING ARM**
- **INCLUDES 2 DRY BOXES THAT CAN BE USED AS BENCHES**
- **L SHAPED TABLE PROVIDED FOR PROCESSING PAPERWORK**
- **4 LIFTING LUGS INCLUDED FOR INSTALLATION VIA CRANE**

**SECTION  
07**

**PUMP PRODUCTS**



**12LS Deepwell Vertical  
Turbine Tank Barge Pump** pg 170



**10LS Deepwell Vertical  
Turbine Tank Barge Pump** pg 171



**12LS Offshore Ballast  
Water Pump** pg 172



**Four Screw Pump** pg 180



**Mechanical Seals** pg 181



**Shaft Coupling - 10LS** pg 183



**Shaft Coupling - 12LS &  
11LS** pg 184



**Outer Bearing Assembly  
Sleeved (OBAS) - 10 LS** pg 185



**Outer Bearing Assembly  
Sleeved (OBAS) - 11 & 12  
LS** pg 186



**Outer Bearing Assembly  
Fixed (OBAF) - 10 LS** pg 187



**Outer Bearing Assembly  
Fixed (OBAF) - 11 & 12 LS** pg 188



**Outer Bearing Assembly  
(OBA) - 10LS** pg 189

**SECTION  
07**

**PUMP PRODUCTS**



**Outer Bearing Assembly  
(OBA) - 12 & 11LS** pg 190



**Companion Flange** pg 191



**Driveshaft- PTO to Right  
Angle Drive** pg 192



**Driveshaft-Laser  
Alignment Tool Kit** pg 193



**APM-2F-APA Anti  
Pollution Alarm** pg 194



## 12LS DEEPWELL VERTICAL TURBINE TANK BARGE PUMP

- **IMPELLER TRIMS FOR EVERY APPLICATION**

The ERL 12LS Pump can accommodate Power Levels from 170HP to 300HP. This is accomplished by trimming the impellers to suit your application. We will customize your pump to suit your needs.

- **11LS AND 12LS PUMP HEADS AVAILABLE**

The ERL 12LS can also accommodate 8"(11LS) and 10"(12LS) Discharge flanges. This allows customers to utilize a 12LS Pump with an 11LS head. This gives you the ability to increase your pump capacity without installing new piping.

- **2 TIMES THE STRENGTH**

We utilize ductile iron on all of our castings. This gives you 2X the strength of the typical cast iron pumps. The result is longer life and better value for you. Stainless steel housings and impellers are also available.

- **DESIGNED USING COMPUTATION FLUID DYNAMICS (CFD) TO ENSURE THE HIGHEST EFFICIENCY**

This software allowed us to optimize every component prior to testing to give our customers the best 12LS in the industry. The result is less fuel and time is needed to discharge a barge. This adds up to value for you.

- **TESTED AT AN ACCREDITED 3RD PARTY LABORATOR**

The testing validated the design calculations and CFD Modeling results. It also ensured our customers get the performance they desire for their application.

- **VERTICAL ASSEMBLY OF ALL PUMPS**

To give our customers the highest quality pump we build each pump vertically to ensure each component is aligned concentrically with the next. Why would anyone build a vertical pump horizontally?





## **10LS DEEPWELL VERTICAL TURBINE TANK BARGE PUMP**

- **IMPELLER TRIMS FOR EVERY APPLICATION**  
The ERL 10LS 3 Stage Pump can accommodate Power Levels from 60HP to 120HP. This is accomplished by trimming the impellers to suit your application. We will customize your pump to suit your needs.
- **10LS (4 STAGE) WITH 11LS PUMP HEAD**  
11LS Flow rates are easily accomplished by using an extra stage on the ERL 10LS. This solution is more economical and a direct replacement to 11LS Pumps. The ERL 10LS 4 stage utilizes an 11LS Head with an 8" (11LS) Discharge Flange.
- **2 TIMES THE STRENGTH**  
We utilize ductile iron on all of our castings. This gives you 2X the strength of the typical cast iron pumps. The result is longer life and better value for you. Stainless steel housings and impellers are also available.
- **DESIGNED USING COMPUTATION FLUID DYNAMICS (CFD) TO ENSURE THE HIGHEST EFFICIENCY**  
This software allowed us to optimize every component prior to testing to give our customers the best 10LS in the industry. The result is less fuel and time is needed to discharge a barge. This adds up to value for you.
- **TESTED AT AN ACCREDITED 3RD PARTY LABORATORY**  
The testing validated the design calculations and CFD Modeling results. It also ensured our customers get the performance they desire for their application.
- **VERTICAL ASSEMBLY OF ALL PUMPS**  
To give our customers the highest quality pump we build each pump vertically to ensure each component is aligned concentrically with the next. Why would anyone build a vertical pump horizontally?



## 12LS OFFSHORE BALLAST WATER VERTICAL PUMP

- **DESIGNED FOR YOUR APPLICATION**  
The ERL 12LS Pump Ballast Water Pump is a single stage vertical pump designed specifically for ballast water applications. Required power level is 75 to 100 HP.
- **11LS, 12LS & 13LS PUMP HEADS AVAILABLE**  
The ERL 12LS can also accommodate 8"(11LS) and 10"(12LS) and 12"(13LS) Discharge flanges. This allows customers to match this 12LS pump to existing piping systems, whatever the size.
- **CORROSION PROTECTION**  
We utilize stainless steel on all of our castings. In addition the pump head and outer columns are manufactured from stainless steel. The result is longer life and better value for you.
- **DESIGNED USING COMPUTATION FLUID DYNAMICS (CFD) TO ENSURE THE HIGHEST EFFICIENCY**  
This software allowed us to optimize every component prior to testing to give our customers the best 12LS in the industry. The result is less fuel and time is needed to discharge or load a barge. This adds up to value for you.
- **SHAFT SUPPORT**  
Our pumps are available with carbon or bronze bushings. Unlike other designs we ensure the maximum distance between bushings is less than 40" for proper support.
- **TESTED AT AN ACCREDITED 3RD PARTY LABORATOR**  
The testing validated the design calculations and CFD Modeling results. It also ensured our customers get the performance they desire for their application.





## DESIGN

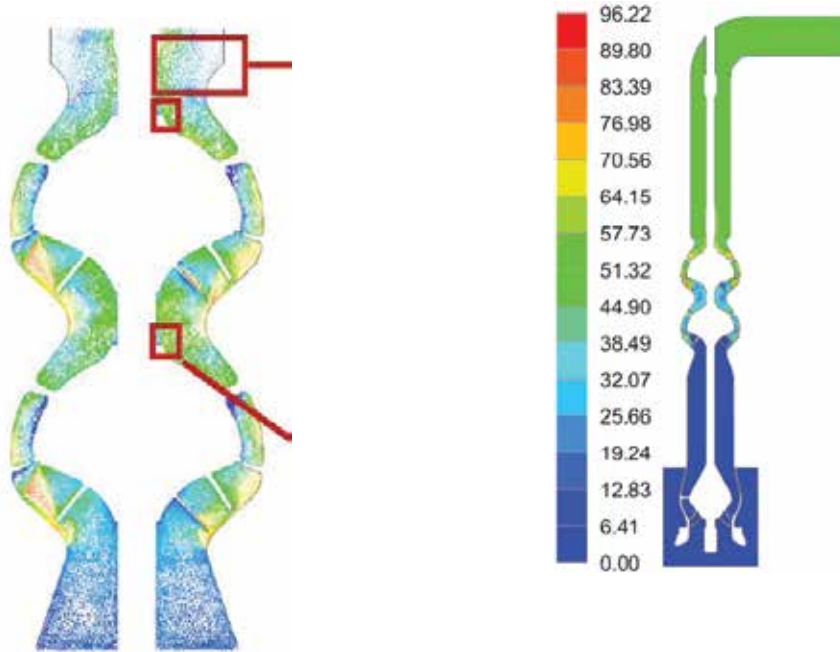

The ERL 10LS and 12LS pumps were designed and modeled to be the highest flowing, most efficient 10LS and 12LS barge pumps on the market. Computational Fluid Dynamics, or CFD, modeling was utilized to test design variations to provide the best components possible.

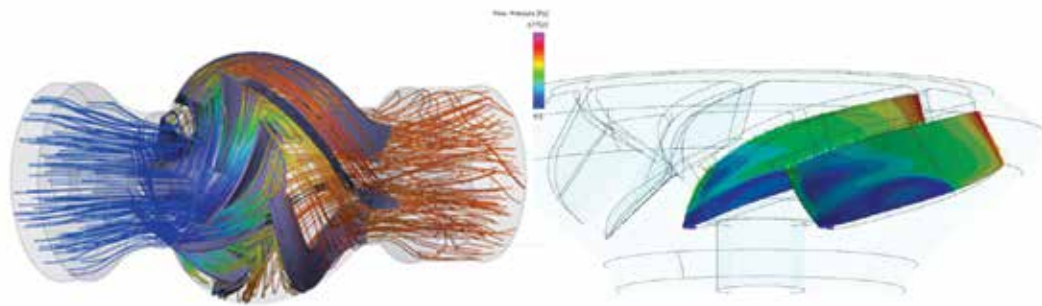

## MANUFACTURING & PRODUCTION



All components for the ERL 10LS and 12LS barge pumps are machined and assembled in a facility in New Albany, Indiana. Our castings are sourced from our local suppliers, produced from our computer models, and manufactured using our own tooling. ERL has constructed a highly functional assembly stations, complete with hydraulic lift pit to allow the components to be assembled vertically.

## TESTING



- The ERL 10LS and 12LS barge pumps were tested at an accredited 3rd party state of the art Testing Laboratory.
- This testing validates the design calculations and CFD modeling results.

	10"	11"	12"	13"
Byron Jackson Barge Pumps	BJ 10LS 3 Stage	BJ 11LS 3 Stage	BJ 12LS 3 Stage	BJ 13LS 3 Stage
ERL Equivalent	ERL 10LS 3 Stage	ERL 10LS 4 Stage	ERL 12 LS 3 Stage	ERL 12 LS 4 Stage
Byron Jackson Discharge Size	6"	8"	10"	10"
ERL Discharge Size	6"	8"	10"	10"
Byron Jackson Pump Head	10LS	11LS	12LS	13LS
ERL Pump Head	10LS	11LS	12LS	13LS
BJ Maximum Flow Rate @100psi	NA	NA	2900 GPM	4800 GPM
ERL Maximum Flow Rate @100psi	NA	NA	3500 GPM	4500 GPM
BJ Maximum Flow Rate @75psi	700 GPM	2000 GPM	NA	NA
ERL Maximum Flow Rate @75psi	1600 GPM	1800 GPM	NA	NA
Byron Jackson Seal	Mech. Seal or Packing	Mech. Seal or Packing	Mech. Seal or Packing	Mech. Seal or Packing
ERL Seal	Mech. Seal or Packing	Mech. Seal or Packing	Mech. Seal or Packing	Mech. Seal or Packing
Byron Jackson Available Materials	Cast Iron or Stainless Steel	Cast Iron or Stainless Steel	Cast Iron or Stainless Steel	Cast Iron or Stainless Steel
ERL Available Materials	Ductile Iron or Stainless Steel	Ductile Iron or Stainless Steel	Ductile Iron or Stainless Steel	Ductile Iron or Stainless Steel



## PERFORMANCE DATA (BARRELS/HOUR)

PERFORMANCE DATA: 12" VERTICAL TURBINE PUMP, 3 STAGE

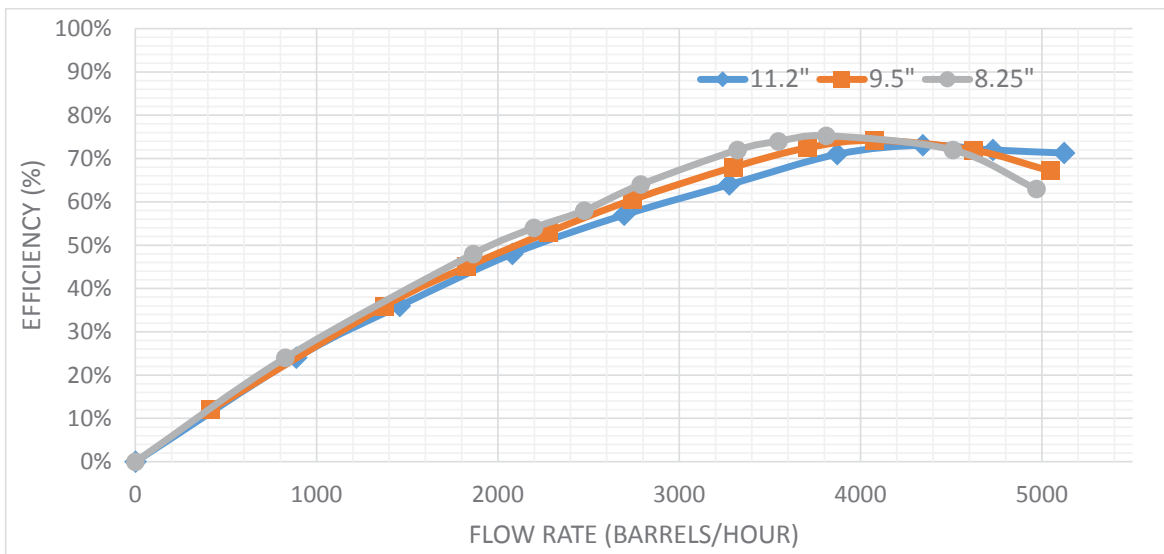
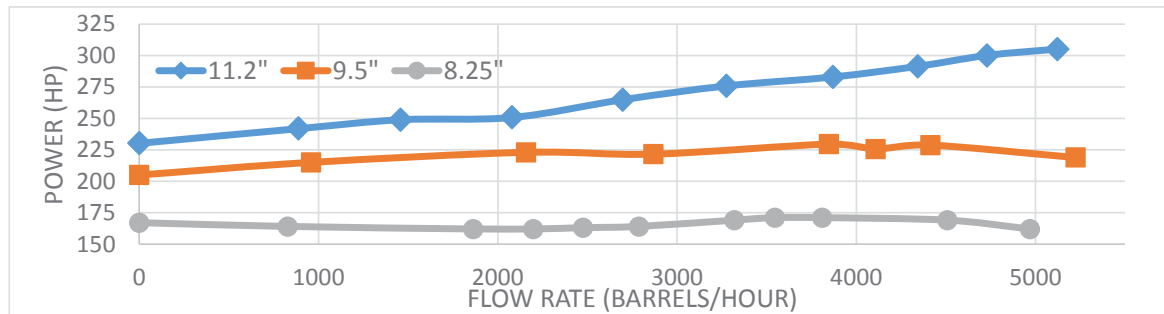
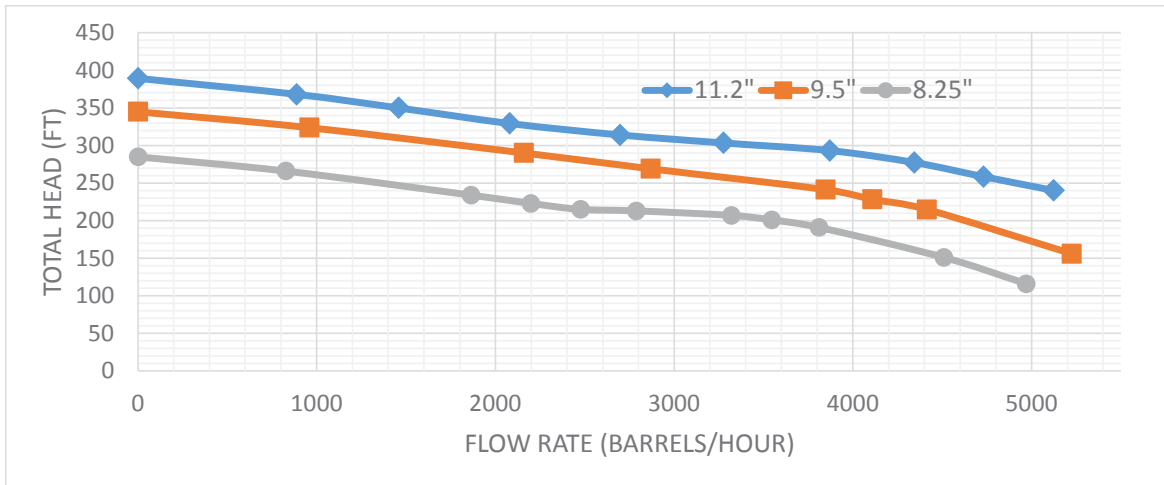

1800 RPM - DUCTILE IRON - OPEN IMPELLER - 1.0SG



### PERFORMANCE DATA

(GPM)

PERFORMANCE DATA: 12" VERTICAL TURBINE PUMP, 3 STAGE

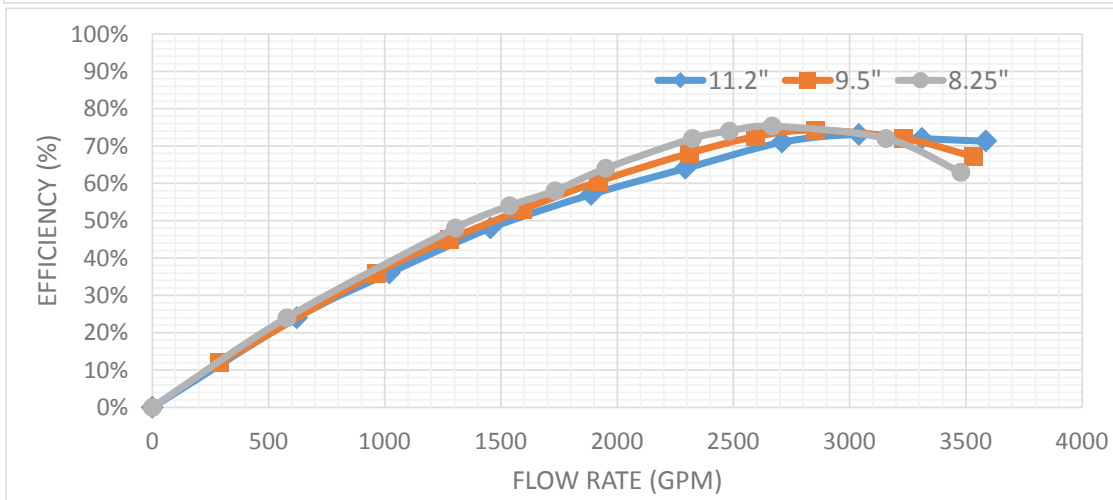
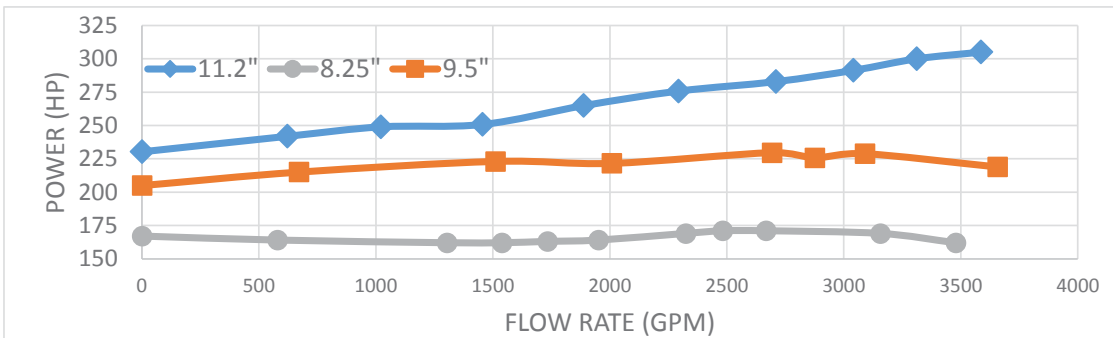
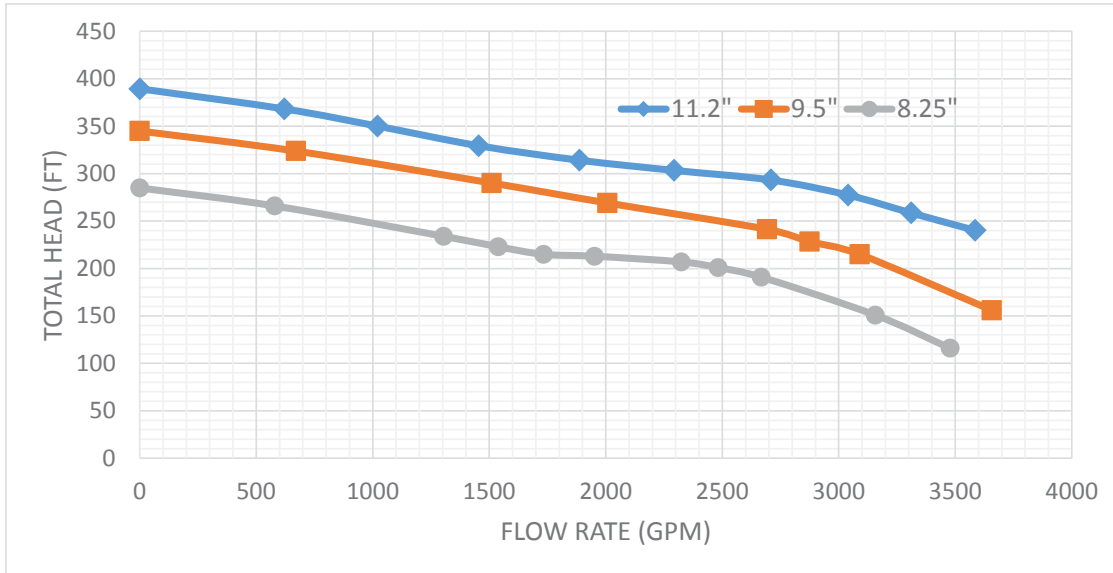

1800 RPM - DUCTILE IRON - OPEN IMPELLER - 1.0SG





## PERFORMANCE DATA COMPARISON: 12" VERTICAL TURBINE PUMP, 3 STAGE ERL 12LS (11.975" TRIM) VS. BYRON JACKSON 12LS "H" IMP (11.375" TRIM)

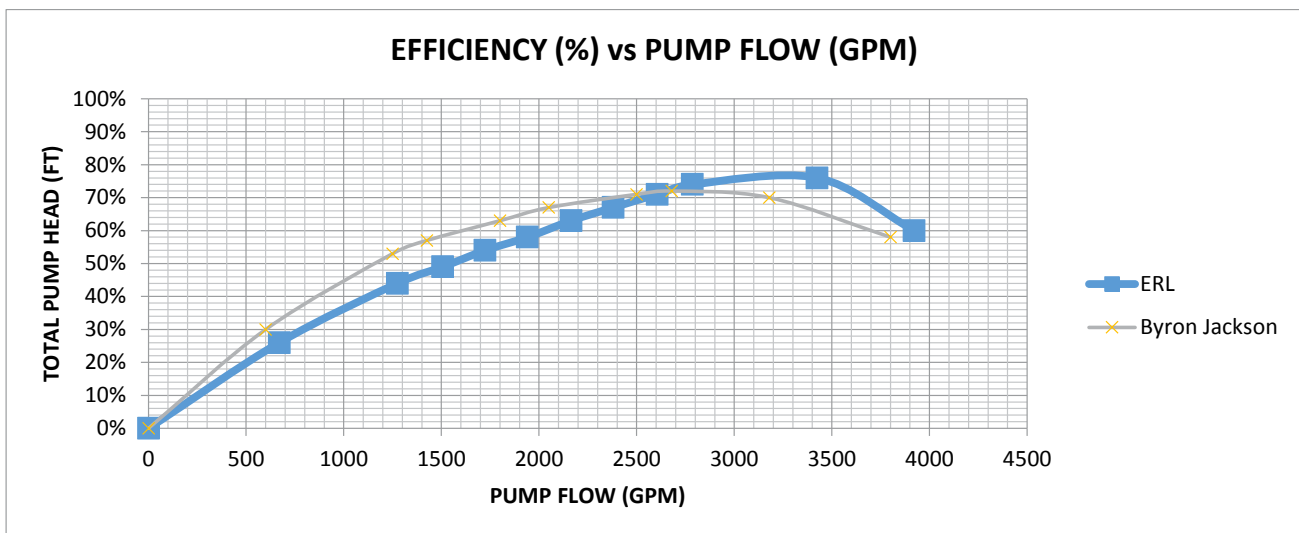
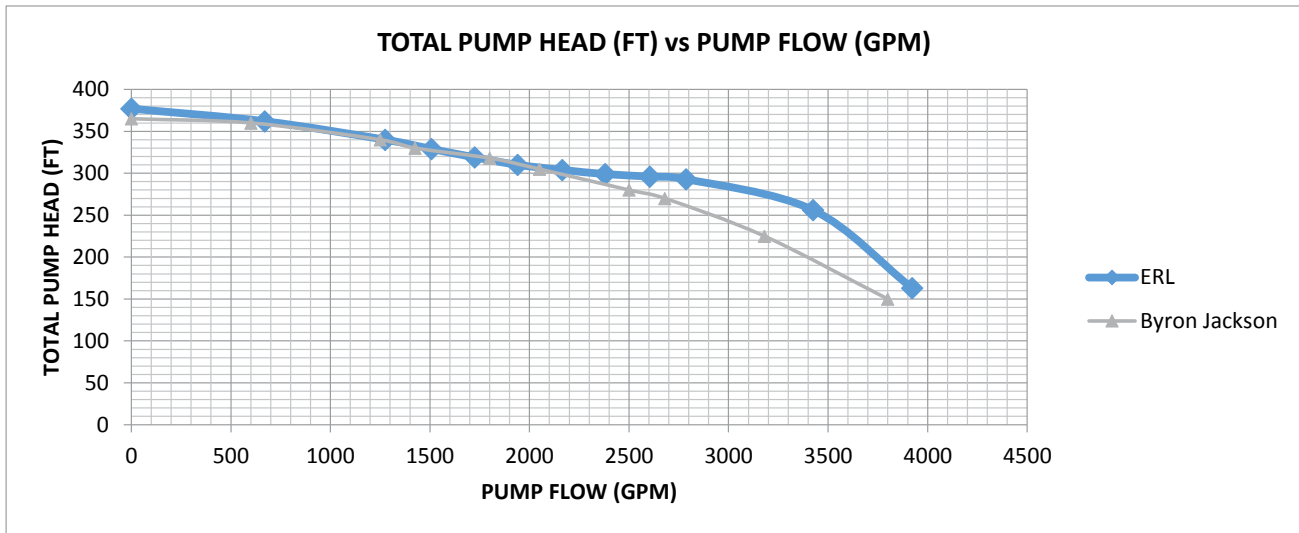

KEY PERFORMANCE INDICATORS	ERL	Byron Jackson
Peak Efficiency	76%	72%
Flow (GPM) @ Peak Efficiency	3425	2680
Flow (Barrels/HR) @ Peak Efficiency	4898	3832
Peak Horsepower	292	260
Shutoff Head (Ft)	377	365
Total Head (Ft) @ 3000 GPM	285	240

1800 RPM - DUCTILE IRON - OPEN IMPELLER - 1.0SG



**Pump Purchase Requisition**

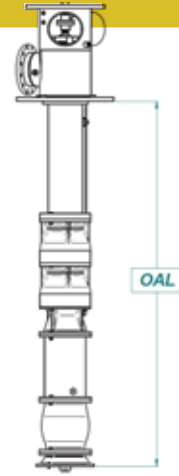

Customer	
Barge Number	
Requisition Number	
Job Number	
Date Issued	
Date Received	
Delivery Date Requested	
Terms	
Notes	

Pump Size (Select One)	10"	11"	12"	13"
Quantity				
Number of Stages (Select One)	2	3	4	5
Cargo				
Heated Cargo (Select One)	Yes	No		
RPM				
Engine Horsepower				
PTO Manufacturer				
Bushing Type (Select One)	Carbon	Bronze		
Type of Carbon	M-130			
Pump Seal Style/Manufacturer	Mechanical Seal	Stuffing Box	Manufacturer:	
Mechanical Seal Shaft Elastomer (Select One)	Kalrez	Teflon	Viton	N/A
Impeller Material (Select One)	Ductile Iron	Stainless Steel		
Impeller Diameter (Inches)	Full	Cut	Cut Diameter:	
Position of Input Shaft (See Below)	Position 1	Position 2	Position 3	
Overall Pump Length (See Above, Inches)				
Right Angle Gear Manufacture (Select One)	Amarillo	Johnson	Other:	
Right Angle Gear (Select One)	S150	S200	S250	Other:
Right Angle Gear Ratio	1:1	5:4	Other:	
Add OBA to Pump, Input Mfg if Yes(Select One)	None	ERL OBA	ERL OBAS	IPS
Right Angle Drive Oil Cooler (Select One)	Yes	No		
Provide Driveshaft / Length (in.)	Yes	No	Length:	
Shaft Coupling Style	Threaded	Ring/Key		
Provide Companion Flanges / Series	PTO	Right Angle Drive	Both	Series:
Discharge Rate (GPM or Barrels/Hr)				
Discharge Pressure (FT TDH or psi)				
Discharge Flange Size (Select One)	8"	10"		
Shaft Material Type (Select One)	416SS	17-4PH		
Pollution Head Drain Configuration	Straight to Can	Tee to 1" NPT Flange		
Pollution Head Drain Ball Valve Style	Self-Closing	Manual w/ Check		
Vent Connection- 1"NPT (Select One)	Threaded	Flanged		
Provide Vent Line (Select One)	Yes	No		
Provide Bypass Line (Select One)	Yes	No		
Pump Head Paint Color Specification				
Pump Head Access Cap (Select One)	Yes	No		

Custom Items/Comments:



## ERL FOUR SCREW VERTICAL TANK BARGE PUMP

- DESIGNED FOR HIGH VISCOCITY CARGO**  
 The ERL Four screw vertical pump is designed to discharge high viscosity cargo from a tank barge, ATB, or chemical tanker.
- CUSTOMIZABLE PUMP HEAD**  
 The ERL Four Screw Pump comes standard with a 10"(12LS) Discharge flange. However, customers can customize this pump head to meet their exact specifications.
- AMARILLO SL500A RIGHT ANGLE GEAR**  
 The Amarillo SL500A Right Angle Drive is standard. This drive can handle power levels up to 500HP and has a ratio of 5:4 or 4:3 to accommodate 1800RPM engines.
- HIGHEST QUALITY MATERIALS**  
 Rotor Housing: 954 Aluminum Bronze.  
 Rotors: 4140 Plasma Nitrided Alloy Steel.  
 Shafts: 416 Stainless Steel.  
 Bushings: Carbon Graphite.
- DESIGNED TO PERFORM**  
 Flow Rate: 2100GPM.  
 Pressure: 100PSI  
 Speed: 1400RPM
- ALLOWABLE CONDITIONS**  
 Cargo Viscosity Ranges: 33 to 20,000SSU.  
 Temperature Ranges: 0 to 300°F.  
 Maximum Speed: 1500RPM.

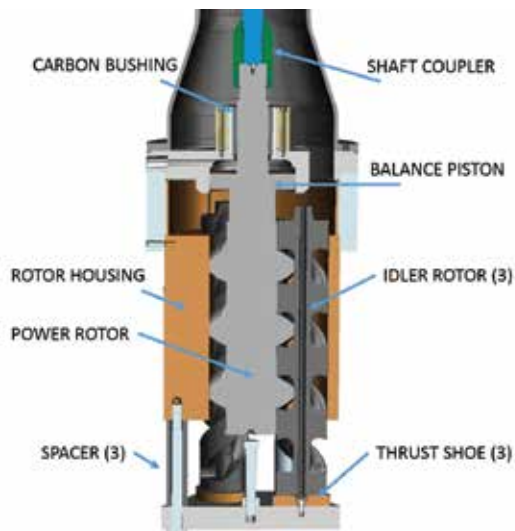
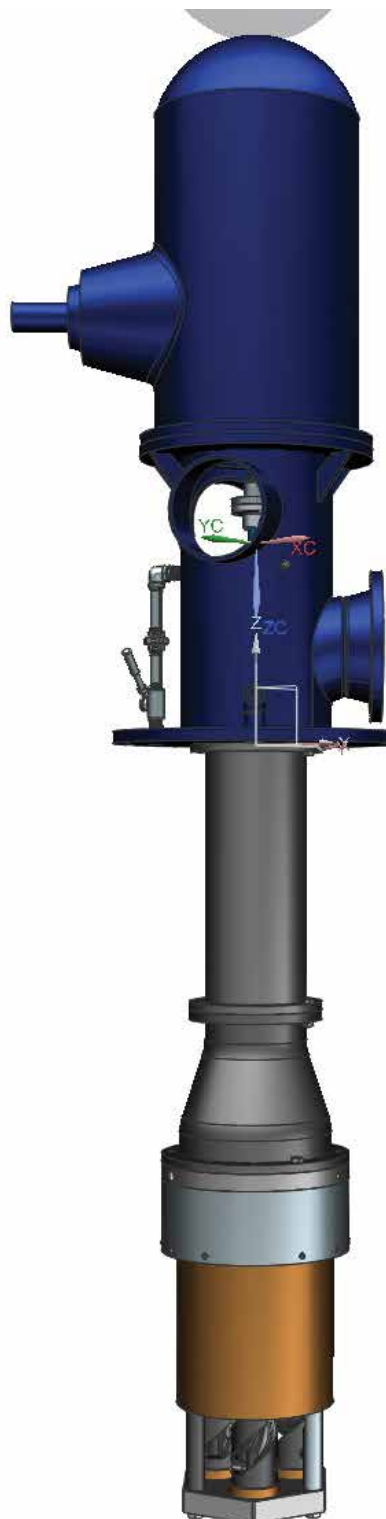



## ERL UC2250 MECHANICAL SEAL

- **DESIGNED FOR 11LS, 12LS & 13LS PUMPS**

The ERL UC2250 is designed as the primary seal for tank barge cargo discharge pumps with a shaft size of 1 15/16". The UC 2250 has been the standard of the industry for over 20 years.

- **SHAFT SAVER EXCLUSIVELY FROM ERL**

The ERL UC2250 comes standard with ERL shaft saver technology that eliminates shaft damage from set screws. The set screws contact a hardened stainless steel ring that locks the sleeve onto the shaft.

- **DLC COATED EXCLUSIVELY FROM ERL**

Optional Coating: Seal faces coated with DLC (Diamond Like Carbon). The hardest & lowest friction surface on earth! Perfect for harsh cargos such as crude oil.

- **BEST PRICE & HIGHEST QUALITY**

Purchase direct from manufacturer. All of the machined components are manufactured at ERL on state of the art equipment.

- **HIGHEST QUALITY MATERIALS**

All Machined Components: 316 Stainless Steel.  
Rotating Face: Silicon Carbide.  
Fixed Face: Carbon Graphite or Silicon Carbide.  
U-Cup: PTFE. Rotating O-ring: Kalrez. Fixed O-ring: FEP

- **EASY REMOVAL**

The ERL UC2250 has jack screw holes machined in the gland for easy removal from the pump head.

- **ERL SHAFT SAVER TECHNOLOGY**

Eliminate shaft damage such as nicks, burrs, and grooves. When the set screws are tightened, they contact a hardened stainless steel ring that compresses onto the shaft.

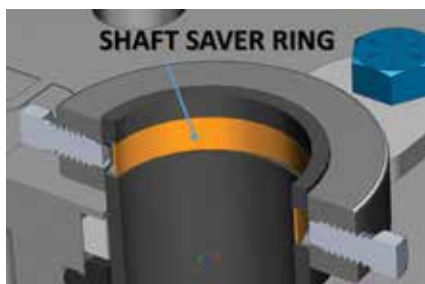

## ERL UC1875 MECHANICAL SEAL

- **DESIGNED FOR 10LS PUMPS**

The ERL UC1875 is designed as the primary seal for tank barge cargo discharge pumps with a shaft size of 1 7/16". The UC1875 has been the standard of the industry for over 20 years.

- **SHAFT SAVER EXCLUSIVELY FROM ERL**

The ERL UC1875 comes standard with ERL shaft saver technology that eliminates shaft damage from set screws. The set screws contact a hardened stainless steel ring that locks the sleeve onto the shaft.

- **DLC COATED EXCLUSIVELY FROM ERL**

Optional Coating: Seal faces coated with DLC (Diamond Like Carbon). The hardest, lowest friction surface on earth! Perfect for very harsh cargos such as crude oil.

- **BEST PRICE & HIGHEST QUALITY**

Purchase direct from manufacturer. All of the machined components are manufactured at ERL on state of the art equipment.

- **HIGHEST QUALITY MATERIALS**

All Machined Components: 316 Stainless Steel.  
Rotating Face: Silicon Carbide.  
Fixed Face: Carbon Graphite or Silicon Carbide.  
U-Cup: PTFE. Rotating O-ring: Kalrez. Fixed O-ring: FEP

- **EASY REMOVAL**

The ERL UC1875 has jack screw holes machined in the gland for easy removal from the pump head.

- **ERL SHAFT SAVER TECHNOLOGY**

Eliminate shaft damage such as nicks, burrs, and grooves. When the set screws are tightened, they contact a hardened stainless steel ring that compresses onto the shaft.

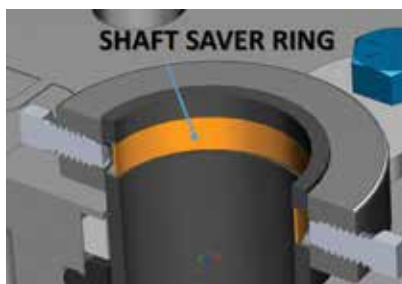

## SHAFT COUPLING – 10LS



- **BOLTED SHAFT COUPLING**

ERL's two piece bolted shaft coupling replaces the standard single piece threaded coupler. The pump torque locks the single piece threaded coupling creating a maintenance nightmare. The two piece bolted shaft coupler gives you easy access to the OBA and mechanical seal.

- **TEFLON COATED NUTS**

ERL has coated every nut with Teflon allowing you to easily remove the coupling for mechanical seal maintenance. The Teflon coating prevents galling between the stainless steel bolts and nuts.

- **100% STAINLESS STEEL CONSTRUCTION**

ERL's Shaft Coupling is completely constructed of 300 series stainless steel. It is manufactured on CNC machines to accurately control dimensional quality.

- **DOUBLE THREADED AND THREADED/KEYED VERSIONS AVAILABLE**

ERL supplies two types of couplings depending on your pump design. The first type has a threaded coupler and a keyed coupler. The second type has two threaded couplers. Either way ERL has the shaft coupling for your application.

## SHAFT COUPLING – 12LS & 11LS



- **BOLTED SHAFT COUPLING**

ERL's two piece bolted shaft coupling replaces the standard single piece threaded coupler. The pump torque locks the single piece threaded coupling creating a maintenance nightmare. The two piece bolted shaft coupler gives you easy access to the OBA and mechanical seal.

- **TEFLON COATED NUTS**

ERL has coated every nut with Teflon allowing you to easily remove the coupling for mechanical seal maintenance. The Teflon coating prevents galling between the stainless steel bolts and nuts.

- **100% STAINLESS STEEL CONSTRUCTION**

ERL's Shaft Coupling is completely constructed of 300 series stainless steel. It is manufactured on CNC machines to accurately control dimensional quality.

- **DOUBLE THREADED AND THREADED/KEYED VERSIONS AVAILABLE**

ERL supplies two types of couplings depending on your pump design. The first type has a threaded coupler and a keyed coupler. The second type has two threaded couplers. Either way ERL has the shaft coupling for your application.

## **OUTER BEARING ASSEMBLY SLEEVED (OBAS) – 10 LS**



- **SELF ALIGNING BEARING**

ERL's OBA utilizes a self-aligning Ball Bearing. This style of Ball bearing has a spherical outer race that allows for small amounts of angular misalignment of the shaft relative to the housing. This reduces friction and heat at high speeds. It also puts less bending load on the shaft, increasing life.

- **TIRED OF REPLACING MECHANICAL SEALS?**

ERL's OBA gives support to the pump shaft directly above the mechanical seal. This greatly reduces the stress on the mechanical seal from vibration caused by the diesel engine and the pump. The result is a longer lasting mechanical seal and less maintenance.

- **100% STAINLESS BEARING HOUSING**

ERL's OBA Housing is completely constructed of 300 series stainless steel for long life. CNC machined bearing bore has a tolerance of  $+.0004''$  for exceptional fit. This allows the spherical bearing to accommodate slightly misalignment in the pump shaft while maintaining support for the mechanical seal.

- **ALIGNMENT LIP**

ERL aligns the OBA with the mechanical seal through a male snap fit. This ensures the OBA gives the mechanical the support it needs for the longest life possible.



## OUTER BEARING ASSEMBLY SLEEVED (OBAS) – 11 & 12 LS



- **SELF ALIGNING BEARING**  
ERL's OBA utilizes a self-aligning Ball Bearing. This style of Ball bearing has a spherical outer race that allows for small amounts of angular misalignment of the shaft relative to the housing. This reduces friction and heat at high speeds. It also puts less bending load on the shaft, increasing life.
- **TIRED OF REPLACING MECHANICAL SEALS?**  
ERL's OBA gives support to the pump shaft directly above the mechanical seal. This greatly reduces the stress on the mechanical seal from vibration caused by the diesel engine and the pump. The result is a longer lasting mechanical seal and less maintenance.
- **100% STAINLESS BEARING HOUSING**  
ERL's OBA Housing is completely constructed of 300 series stainless steel for long life. CNC machined bearing bore has a tolerance of  $+.0004''$  for exceptional fit. This allows the spherical bearing to accommodate slightly misalignment in the pump shaft while maintaining support for the mechanical seal.
- **ALIGNMENT LIP**  
ERL aligns the OBA with the mechanical seal through a male snap fit. This ensures the OBA gives the mechanical the support it needs for the longest life possible.



## OUTER BEARING ASSEMBLY FIXED (OBAF) – 10 LS

- **TIRED OF REPLACING MECHANICAL SEALS?**

ERL's OBAF gives support to the pump shaft directly above the mechanical seal. This greatly reduces the stress on the mechanical seal from vibration caused by the diesel engine and the pump. The result is a longer lasting mechanical seal and less maintenance.

- **100% STAINLESS BEARING HOUSING**

ERL's OBAF Housing is completely constructed of 300 series stainless steel for long life. CNC machined to tight tolerances to allow for proper fitment of the bearing and provide proper support the mechanical seal.

- **ALIGNMENT LIP**

ERL aligns the OBAF with the mechanical seal through a male snap fit. This ensures the OBAF gives the mechanical the support it needs for the longest life possible.

- **LIP SEAL**

A lip seal is provided to seal the top side of the bearing from water and cargo to ensure maximum life.

- **SEALED BEARING**

Sealed cylindrical bearing eliminates the need for maintenance to grease the bearing and eliminates the potential for contamination.

- **STAINLESS STEEL SLEEVE**

The bearing is attached to the shaft with a Stainless Steel Sleeve which eliminates potential corrosion issues to aid in disassembly. The sleeve also features ERL's shaft saver technology which eliminates the potential for marring the shaft when tightening the set screws to the pump shaft. The shaft saver utilizes a hardened steel ring which ensures a tight shaft connection without damaging the shaft.

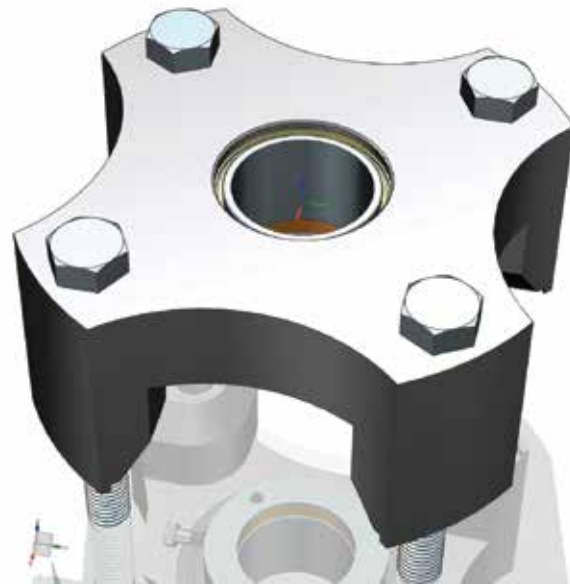
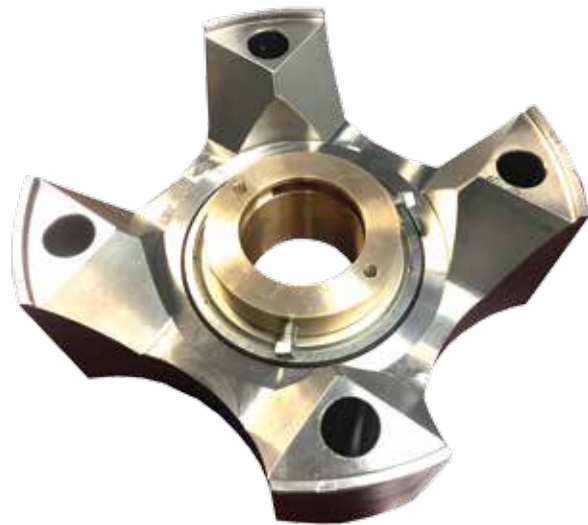

## OUTER BEARING ASSEMBLY FIXED (OBAF) – 11 & 12 LS

- **TIRED OF REPLACING MECHANICAL SEALS?**

ERL's OBAF gives support to the pump shaft directly above the mechanical seal. This greatly reduces the stress on the mechanical seal from vibration caused by the diesel engine and the pump. The result is a longer lasting mechanical seal and less maintenance.

- **100% STAINLESS BEARING HOUSING**

ERL's OBAF Housing is completely constructed of 300 series stainless steel for long life. CNC machined to tight tolerances to allow for proper fitment of the bearing and provide proper support the mechanical seal.

- **ALIGNMENT LIP**

ERL aligns the OBAF with the mechanical seal through a male snap fit. This ensures the OBAF gives the mechanical the support it needs for the longest life possible.

- **LIP SEAL**

A lip seal is provided to seal the top side of the bearing from water and cargo to ensure maximum life.

- **SEALED BEARING**

Sealed cylindrical bearing eliminates the need for maintenance to grease the bearing and eliminates the potential for contamination.

- **STAINLESS STEEL SLEEVE**

The bearing is attached to the shaft with a Stainless Steel Sleeve which eliminates potential corrosion issues to aid in disassembly. The sleeve also features ERL's shaft saver technology which eliminates the potential for marring the shaft when tightening the set screws to the pump shaft. The shaft saver utilizes a hardened steel ring which ensures a tight shaft connection without damaging the shaft.

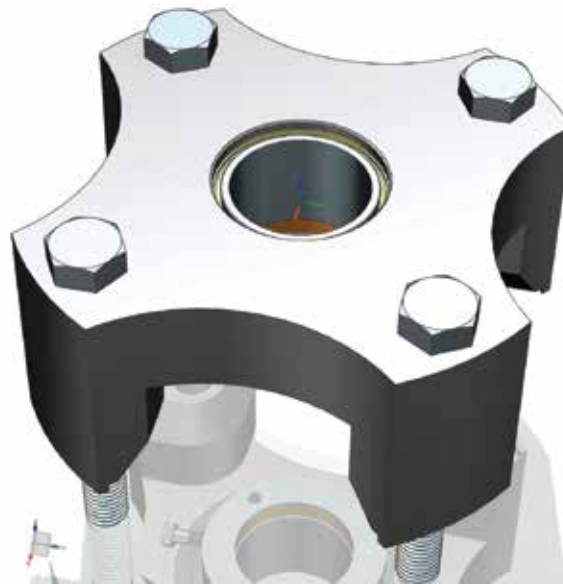
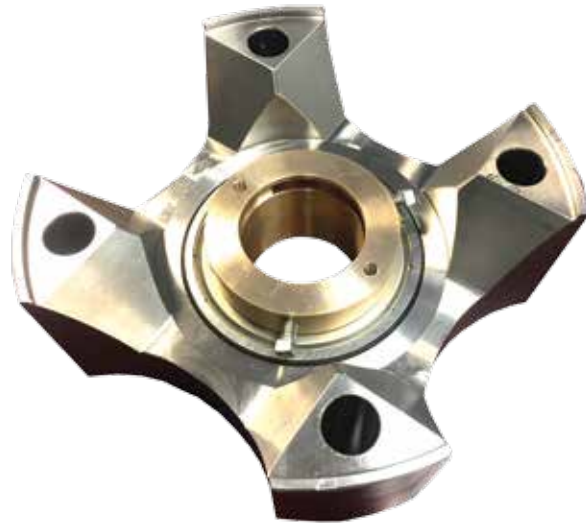

## **OUTER BEARING ASSEMBLY (OBA) -10LS**

- **SELF ALIGNING BEARING**

ERL's OBA utilizes a self-aligning Ball Bearing. This style of Ball bearing has a spherical outer race that allows for small amounts of angular misalignment of the shaft relative to the housing. This reduces friction and heat at high speeds. It also puts less bending load on the shaft, increasing life.

- **TIRED OF REPLACING MECHANICAL SEALS?**

ERL's OBA gives support to the pump shaft directly above the mechanical seal. This greatly reduces the stress on the mechanical seal from vibration caused by the diesel engine and the pump. The result is a longer lasting mechanical seal and less maintenance.

- **100% STAINLESS BEARING HOUSING**

ERL's OBA Housing is completely constructed of 300 series stainless steel for long life. CNC machined bearing bore has a tolerance of  $\pm .0004$ " for exceptional fit. This allows the spherical bearing to accommodate slightly misalignment in the pump shaft while maintaining support for the mechanical seal.

- **TIRED OF REMOVING MECHANICAL SEALS PAST BURRS?**

ERL utilizes Timken's shaft guard technology which prevents the set screw from damaging the shaft. This ensures the OBA and mechanical seal are easily replaced without sliding over a burr. Each set screw transfers pressure to the shaft through a stainless-steel hardened band. This eliminates direct shaft-setscrew contact. Truly a first in the commercial marine industry.

- **CORROSION RESISTANT BALL BEARING**

The Ball bearing utilizes Timken stainless steel balls and a thin dense-chrome bearing coating for optimum corrosion resistance. This technology is proven and sets a marine industry standard.

- **ALIGNMENT LIP**

ERL aligns the OBA with the mechanical seal through a male snap fit. This ensures the OBA gives the mechanical the support it needs for the longest life possible.



## OUTER BEARING ASSEMBLY (OBA) -12LS & 11LS



- **SELF ALIGNING BEARING**

ERL's OBA utilizes a self-aligning Ball Bearing. This style of Ball bearing has a spherical outer race that allows for small amounts of angular misalignment of the shaft relative to the housing. This reduces friction and heat at high speeds. It also puts less bending load on the shaft, increasing life.

- **TIRED OF REPLACING MECHANICAL SEALS?**

ERL's OBA gives support to the pump shaft directly above the mechanical seal. This greatly reduces the stress on the mechanical seal from vibration caused by the diesel engine and the pump. The result is a longer lasting mechanical seal and less maintenance.

- **100% STAINLESS BEARING HOUSING**

ERL's OBA Housing is completely constructed of 300 series stainless steel for long life. CNC machined bearing bore has a tolerance of  $\pm .0004$ " for exceptional fit. This allows the spherical bearing to accommodate slightly misalignment in the pump shaft while maintaining support for the mechanical seal.

- **TIRED OF REMOVING MECHANICAL SEALS PAST BURRS?**

ERL utilizes Timken's shaft guard technology which prevents the set screw from damaging the shaft. This ensures the OBA and mechanical seal are easily replaced without sliding over a burr. Each set screw transfers pressure to the shaft through a stainless-steel hardened band. This eliminates direct shaft-setscrew contact. Truly a first in the commercial marine industry.

- **CORROSION RESISTANT BALL BEARING**

The Ball bearing utilizes Timken stainless steel balls and a thin dense-chrome bearing coating for optimum corrosion resistance. This technology is proven and sets a marine industry standard.

- **ALIGNMENT LIP**

ERL aligns the OBA with the mechanical seal through a male snap fit. This ensures the OBA gives the mechanical the support it needs for the longest life possible.



## COMPANION FLANGE

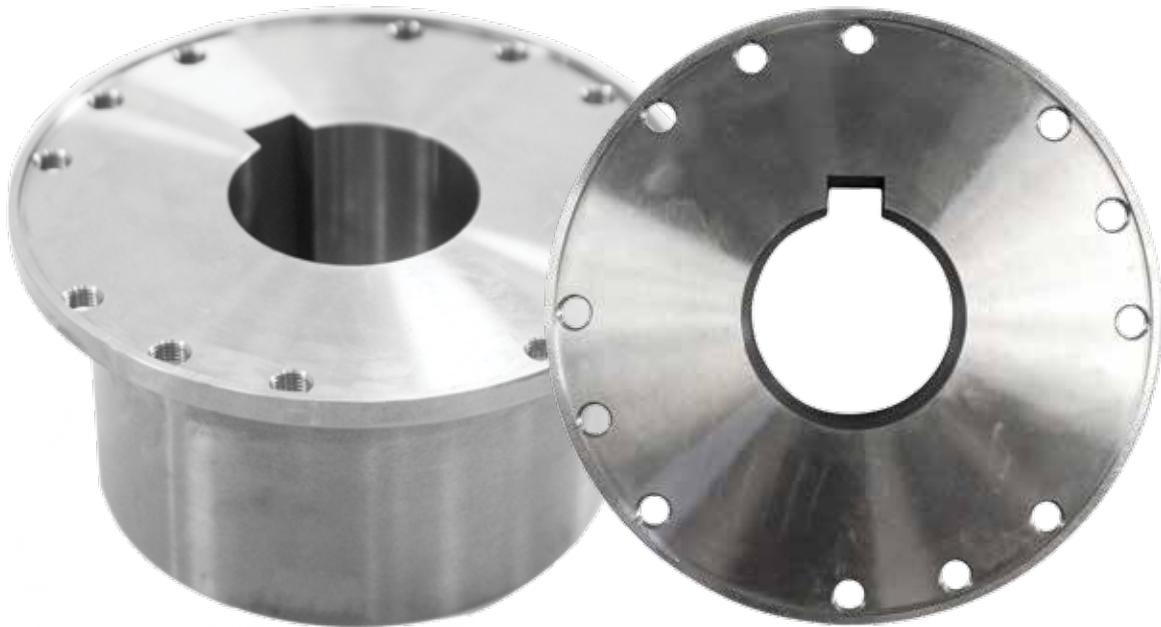

- **PUMP POWERTRAIN**

ERL supplies companion flanges for connecting the right angle drive to the driveshaft and the driveshaft to the Power Take Off (PTO) attached to the Diesel Engine. This is a critical component in the powertrain to drive the discharge pump.

- **MULTIPLE SIZES**

ERL can supply four different sizes based on customer specification. Sizes 1610, 1710, 1810, and 1880 are available. In addition the thru bore is per customer request. All four sizes are also available in Standard Flange (SF) configuration and in Special Large Flange (SLF) configuration.

- **HIGH STRENGTH CARBON STEEL FOR LONGEVITY**

- **PRECISION MANUFACTURING**

Manufactured using state of the art CNC machines that holds each bore to less than .0005" tolerance. This ensures each and every part is of the highest quality.

## DRIVESHAFT- PTO TO RIGHT ANGLE DRIVE



- 4' AND 8' DRIVESHAFT LENGTHS AVAILABLE
- HIGH STRENGTH STEEL FOR DURABILITY
- POWDERCOATED FOR THE MARINE ENVIRONMENT
- INDIVIDUALLY FULLY BALANCED ASSEMBLIES



## DRIVESHAFT-LASER ALIGNMENT TOOL KIT

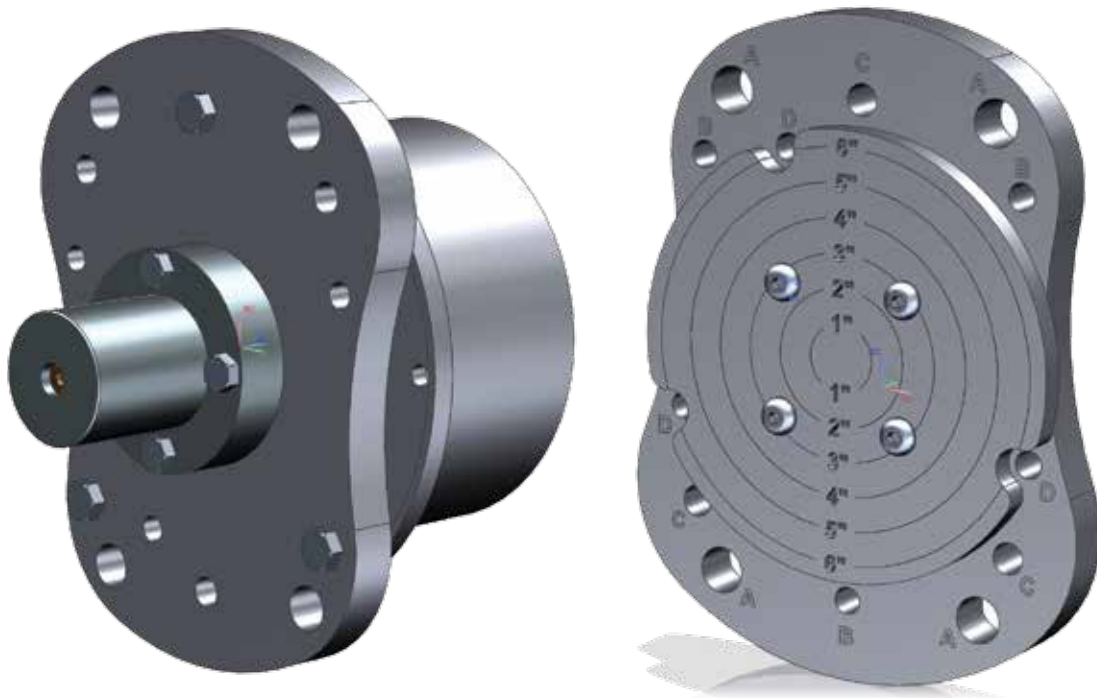

- **SIMPLE DESIGN**

The ERL Laser Alignment tool for driveshaft gives the shipyard a simple yet sophisticated tool to make driveshaft installation a breeze.

- **MARINE GRADE MATERIALS**

ERL utilizes 300 series stainless housing and target. The laser is inside a bronze housing for durability.

- **EFFECTIVE TOOL**

Driveshaft vibration and failure is commonly caused by misalignment during the installation. The ERL laser alignment tool ensures that the Diesel engine and PTO are installed in exactly the right location the first time.

- **INSTRUCTIONS**

Detailed instructions and drawings are included with the kit. Assembly drawings are also available online at [www.ERLMarine.com](http://www.ERLMarine.com).



## APM-2F-APA ANTI POLLUTION ALARM

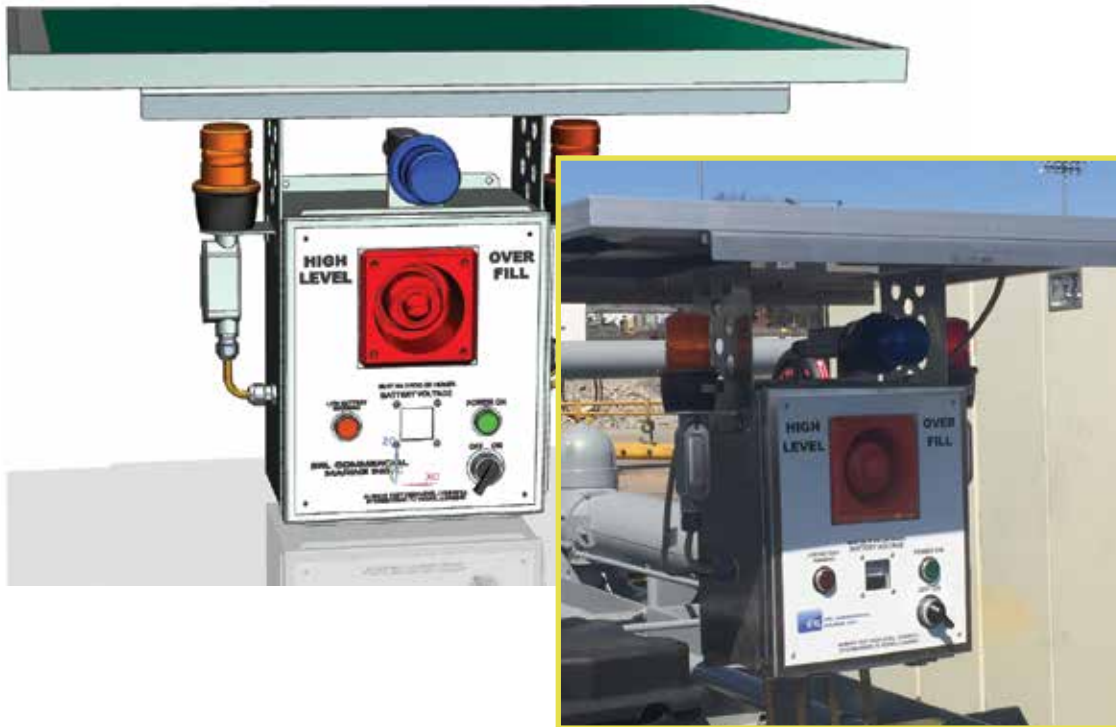

- **FULL REGULATORY COMPLIANCE**

ERL's APM-2 vessel mounted High Level/Overfill Alarm Annunciator Panel satisfies 46 CFR 39.20 9 (a) when connected to an ERL Liquid Level Sensor System. The installation must conform to 46 CFR 111.105 and API Recommended Practice 1125. The APM-2 Alarm Panel is U.S. Coast Guard accepted and satisfies OPA-90 requirements for overfill protection devices and is suitable for ABS classed vessels.

- **QUALITY CONSTRUCTION**

The APM-2's weatherproof cabinet is 100% heavy gauge stainless steel. All electrical components are UL, FM and CSA approved. Each APM-2 Alarm Panel undergoes complete operational testing and final inspection before shipment.

- **CARGO LEVEL ALARM**

The APM-2F contains an audio and visual notification for an occurrence of high level and overfill alarms mounted in the cargo tanks.

- **ANTI-POLLUTION ALARM**

The APA is an intrinsically safe, Class I Div I, float operated switch mounted in the pollution head cavity of the barge cargo pump. The alarm provides notification in the event of a pump seal failure during transfer.

- **SEE PAGE 70 FOR WIRING DIAGRAM**

**SECTION**

**08**

# **REFERENCE INFORMATION**

**CARGO GRADES**

**CONVERSION TABLES**

**MARINE TERMS AND DEFINITIONS**



## CARGO GRADES

The Grade classifications assigned by the U.S. Coast Guard to FLAMMABLE or COMBUSTIBLE liquids are defined as follows:

<b>GRADE A</b>	<b>Flammable liquid with a Reid vapor pressure of 14 pounds per square inch absolute (PSIA) or more.</b>
<b>GRADE B</b>	<b>Flammable liquid with a Reid vapor pressure under 14 pounds per square inch absolute (PSIA) and over 8.5 pounds per square inch.</b>
<b>GRADE C</b>	<b>Flammable liquid with a Reid vapor pressure of 8.5 pounds per square inch absolute (PSIA) or less and a flashpoint of 80deg F or below.</b>
<b>GRADE D</b>	<b>Combustible liquid with a flash point above 80deg F, but below 150deg F.</b>
<b>GRADE E</b>	<b>Combustible liquid with a flash point of 150deg F or above.</b>

### RELEVANT DEFINITIONS

**Reid Vapor Pressure:** Equilibrium exerted by vapor over liquid at 100°F, expressed as pounds per square inch absolute (PSIA) as defined in 46 CFR 30.10-59.

**Vapor Density:** This is actually a specific gravity rather than a true density because it equals the ratio of the weight of a vapor or gas (with no air present) compared to the weight of an equal volume of air at the same temperature and pressure. Values less than 1 indicate that the vapor or gas tends to settle. However, temperature effects must be considered.

**Flash Point:** The lowest temperature at which the vapors of a liquid may be ignited momentarily. Values given in the data sheets are open cup except when designated "(cc)," which indicates the closed cup value. In general the open cup value is about 10° to 15°F above the closed cup value.

**Flammable Limits:** The range of gas or vapor concentrations (percent by volume in air) which will burn or explode if an ignition source is present. Limiting concentrations are commonly called the "lower explosive limit" (LEL) and the "upper explosive limit" (UEL). Below the LEL the mixture is too lean to burn, and above the UEL, the mixture is too rich to burn.



### CONVERSION FACTORS

Metric Units Used In Part 153

Parameter	Metric (SI unit)	Abbreviation	Equivalent to English or common metric
Force	Newton	N	0.225 lbs.
Length	Meter	m	39.37 in.
	Centimeter	cm	.3937 in.
Pressure	Pascal	Pa	1.450 x 10 <sup>-4</sup> lbs/in <sup>2</sup> .
	Kilo-Pascal (1,000 Pascals)	kPa	0.145 lbs/in <sup>2</sup> .
	Kilo-Pascal	kPa	1.02 x 10 <sup>-2</sup> kg/cm <sup>2</sup> .
	do	kPa	1 X 10 <sup>3</sup> N/m <sup>2</sup> .
Temperature	Degree Celsius	°C	5/9 (°F-32).
Viscosity	milli-Pascal second	mPa.sec	1.0 centipoise.
Volume	Cubic meter	m <sup>3</sup>	264 gallons (gal).
	do	m <sup>3</sup>	35.3 ft <sup>3</sup> .

#### “RULE OF THUMB”

Specific gravity of water:  
 fresh = 1.00  
 salt = 1.025 (approx.)

#### VISCOSITY

Centistokes x density (grams per ml.) = centipoises  
 Kinematic viscosity x density = absolute viscosity

#### DENSITY

Pound per gal. (U.S.) at 20°C = specific gravity at 20/20°C x 8.32162  
 Pound per gal. (U.S.) = 0.119826 grams per ml.

#### TEMPERATURE CONVERSIONS

Fahrenheit to Celsius  $C = (F - 32) \times .556$   
 Celsius to Fahrenheit  $F = (C \times 1.8) + 32$



## MARINE TERMS AND DEFINITIONS

**ABS** - American Bureau of Shipping; a vessel classification agency which also assigns international loadlines.

**admeasure** - to measure, calculate, and certify, for the purpose of registration, certain dimensions of a vessel as well as its gross and net tons.

**affreightment** - a contract for the movement of cargo, in which the cargo owner/shipper is neither charterer nor operator of the vessel.

**AHP** - Above Head of Passes; used with mileage designations on the Mississippi River, the Head of Passes being mile zero.

**AIWW** - Atlantic Intracoastal Waterway.

**anchor billboard** - a structure on the deck of a vessel upon which the anchor is mounted when not in use.

**anodes** - metallic plates which, when attached to the hull of a vessel, decompose due to electrolysis, reducing deterioration of the hull plate.

**athwartship** - transverse or across a vessel from side to side.

**autoignition temperature** - the minimum temperature required to ignite gas or vapor without a spark or flame being present. Values given are only approximate and may change substantially with changes in geometry, gas, or vapor concentrations, presence of catalysts, or other factors.

**ballast** - any substance, other than cargo, which is usually placed in the inner compartment of a vessel to produce a desired draft or trim.

**bareboat charter** - (demise charter) a form of vessel rental in which the charterer assumes total responsibility for the vessel and its operations as if it was their own.

**beam** - the breadth of a vessel.

**bell suction** - the flared open end of a cargo pipeline which is situated at close tolerances to the bottom of a liquid cargo tank.

**bilge** - the lower inner space of a vessel's hull.

**bin** - a walled enclosure built on the deck of a barge for the purpose of retaining cargo; also called a pen or cargo box.

**bitt** - (bollard or timberhead) a single or double post on a vessel or wharf to which lines are tied.

**boiling point** - the temperature at which the liquid boils, given in °C and °F at a pressure of 760 mm Hg, one atmosphere or 14.7 psia. Thus, the boiling point is the temperature at which the vapor pressure is 760 mm Hg, one atmosphere or 14.7 psia.

**bollard pull** - the static pulling force of a tugboat measured in pounds.

**bounding angle** - a steel angle used for reinforcement at the junction of two steel plates.

**bow** - the forward or front end of a vessel.

**boxed end** - the end of a barge which is squared for the full depth and width of the hull.

**bridle** - a V-shaped chain, wire, or rope attached to a vessel being towed to which the towline is connected.

**buck frame** - a transverse truss.

**bulkhead** - an upright partition separating compartments.



## MARINE TERMS AND DEFINITIONS

**bulwark** - the side of a vessel which extends above the upper deck.

**buoy** - a stationary floating object used as an aid for navigation.

**butterworth** - a washing process used to gas free or clean a cargo tank, employing hot water or chemicals, sprayed through a patented rotating nozzle.

**butterworth opening** - a deck access opening with bolted cover, designed for butterworth operations.

**camber** - the upward slope of a vessel's deck, occurring when the centerline is higher than the gunnel.

**camel** - a pontoon used to fender between a vessel and a wharf.

**capstan** - a hand or machine powered, vertical, spindle-mounted drum which rotates and pulls lines by winding.

**certification** - attesting that a vessel has met specific legal requirements by the issuance of various certificates or validation of documents by certain governmental or private agencies.

**channel** - that portion of a waterway which is naturally or artificially deepened to permit safe navigation within certain limits.

**charter party** - a contractual agreement between two entities for the purpose of renting, hiring, or leasing the exclusive use of a vessel.

**chock** - a heavy metal casting through which lines may pass for mooring or towing.

**CHRIS code** - the three letter designation assigned to every entry in the Chemical Hazard Response Information System.

**CIF** - cost, insurance, and freight; cost of transportation and insurance to be paid by the seller of goods to the named point of destination.

**classification** - the certification process as administered by certain international agencies whereby a vessel is designed, constructed, and maintained to an agency's requirements.

**cleat** - a metal fitting with two projecting horns, around which a rope may be made fast.

**clip** - a small steel bracket used for securing or reinforcing.

**coaming** - a watertight, raised framework around an opening in the deck of a vessel.

**cofferdam** - the space in a vessel between two closely located parallel bulkheads.

**coils** - a system of small diameter pipes installed inside a liquid cargo tank for the purpose of heating the cargo by means of hot oil or steam.

**comehome** - a convex curvature of the rake sides of a barge that produces a narrower beam at the headlog than the beam of the hull.

**common carrier** - a federally licensed company which offers to the general public, under published tariffs, to engage in interstate or foreign transportation of commodities of various types.

**compartment** - an interior space of a vessel's hull which is formed by bulkheads.

**contract carrier** - a federally licensed company which offers under individual contracts to engage in interstate or foreign transportation of commodities of various types.

**daymark** - a marker used as an aid to navigation which is visible in daylight.



## MARINE TERMS AND DEFINITIONS

**deadrise** - the upward slope of a vessel's bottom occurring when the centerline is deeper than the bilge knuckle; provided to facilitate removal of liquid cargo.

**deadweight tonnage** - the cargo capacity of a vessel.

**demurrage** - a charge assessed for detaining a vessel beyond the free time stipulated for loading or unloading.

**detention** - the period of time that an owner or charterer is deprived of the use of his vessel as a result of actions of another party.

**docking tug** - a tugboat which assists a large seagoing vessel to and from its berth.

**documentation** - the process of licensing a vessel in either enrollment or registry, resulting in the issuance of a vessel's official document.

**dolphin** - a cluster of piles driven into the bottom of a waterway and bound firmly together for the mooring of vessels.

**doubler** - a steel plate installed on an existing structural plate and used as a repair of a damaged area.

**draft** - the depth of a vessel's keel below the waterline; often expressed as light draft, conversely, loaded draft.

**draft marks** - the numerical markings on the sides of a vessel at the bow and stem, which indicate, at the lower edge of the number, the amount of water the vessel draws.

**drip pan** - an open container, located on deck under the ends of a pipeline header to retain cargo drippage. Required on all U.S.C.G. certified tank barges.

**drydocking** - the removal of a vessel from the water to accomplish repairs or inspections.

**dumb vessel** - a vessel without means of self-propulsion.

**dunnage** - any materials used to block or brace cargo to prevent its motion, chafing, or damage and to facilitate its handling.

**EHL** - East of Harvey Lock; used with mileage designations on the Gulf Intracoastal Waterway, Harvey Lock being mile zero.

**ETA** - Estimated Time of Arrival.

**ETD** - Estimated Time of Departure.

**expansion trunk** - a raised enclosure around an opening in the top of a liquid cargo tank which allows for heat expansion of the cargo.

**exposure procedures** - first aid procedures recommended by manufacturers and safety organizations. These are emergency procedures only. The victim should be examined by a physician as soon as possible.

**fairing** - re-forming distorted steel to its original form or shape.

**fairlead** - a device consisting of pulleys or rollers arranged to permit reeling in of a cable from any direction; often used in conjunction with winches and, similar apparatus.

**fender** - any device used to absorb and distribute shock and to prevent chafing between a vessel and another object.

**fishplate** - a triangular-shaped steel plate used to strengthen the connection of the towing hawser.



## MARINE TERMS AND DEFINITIONS

**flame screen** - a corrosion-resistant fine wire mesh screen used to cover certain openings on tank vessels to prevent the passage of flame into the tank.

**flammable limits** - the range of gas or vapor concentrations (percent by volume in air) which will burn or explode if an ignition source is present. Limiting concentrations are commonly called the "lower explosive limit" (LEL) and the "upper explosive limit" (UEL). Below the LEL the mixture is too lean to burn, and above the UEL it is too rich to burn.

**flange** - that portion of a steel shape which projects at a right angle to provide strength or a means of attachment to another part.

**flash point** - the lowest temperature at which the vapors of a liquid may be ignited momentarily. Values given in the data sheets are open cup except where designated "(cc)," which indicates the closed cup value. In general, the open cup value is about 10° to 15°F higher than the closed cup value.

**fleet boat** - a boat which primarily tends, tows within, or otherwise services a fleeting area.

**fleeting area** - (fleet) a designated portion of a waterway where vessels are regularly moored and tended.

**F.O.B.** - Free On Board; cargo delivered to and placed on board a carrier at a specific point without charge.

**freeboard** - the distance from the waterline to the main deck of a boat or barge.

**freeing port** - a large opening in the bulward on an exposed deck of a seagoing vessel which provides for the rapid draining of water from that deck.

**freezing point** - the temperature in °C and in °F at which the liquid solidifies.

**fullyfound** - a vessel completely equipped and manned for service.

**gas free** - the process of removing all hazardous gases and residues from the compartments of a vessel.

**gasket** - an elastic packing material used for making joints watertight.

**gauge** - a waterway marker which measures the level of the water in foot increments; also refers to the specific measure on the gauge.

**GIWW** - Gulf Intracoastal Waterway.

**gross tons** - the volume measurement of the internal voids of a vessel wherein 100 cu. ft. equals one ton.

**gunwale** - (funnel) that part of a barge or boat where the main deck and side meet.

**gusset** - a steel plate used for reinforcing or bracing the junction of other steel members.

**harbor boat** - any powered vessel which is used primarily in harbor operations.

**hatch** - a removable cover over the cargo hold of a vessel.

**hawser** - a large circumference rope used for towing or mooring a vessel or securing it at a dock.

**headlog** - the reinforced, vertical plate which connects the bow rake bottom to the rake deck of a barge or square-stemmed boat.

**head of navigation** - the uppermost limit of navigation from the mouth of a waterway.

**hip towing** - (hiping) a method of towing where by the vessel being towed is secured alongside the towboat.





## MARINE TERMS AND DEFINITIONS

**homeport** - the port city which is home base of a vessel or from which it is documented.

**horsepower** - a standard unit of power which is often classified in connection with engines as brake, continuous, input, intermittent, output, or shaft horsepower.

**hull** - the main body of a vessel which provides flotation.

**ICC** - (Interstate Commerce Commission) a U.S. governmental agency which regulates the domestic transportation of certain commodities.

**inland waters** - considered to be the canals, rivers and lakes and their tributaries, and bays and sounds of the land mass of a country.

**integrated tow** - a tow of box-ended barges which as a complete unit is raked at the bow, boxed at the intermediate connections, and boxed or raked at the stem.

**keel** - the lowest structural member of a ship or boat which runs the length of the vessel at the centerline and to which the frames are attached.

**keel line** - an imaginary line describing the lowest portion of a vessel's hull.

**kevel** - (caval) a heavy, metal deck fitting having two horn-shaped arms projecting outward around which lines may be made fast for towing or mooring of a vessel.

**knot** - one nautical mile per hour; used as a unit of measurement in expressing the rate of speed of seagoing vessels and the relative speed of water currents.

**landing** - an improved waterfront property which facilitates loading, unloading, and servicing of vessels.

**lightening hole** - a hole cut in a plate or frame to reduce its weight without reducing its strength.

**lighter** - a vessel, usually a barge, that is used in loading or unloading a ship or in transporting cargo in and around a harbor.

**light screen** - a structure surrounding a vessel's navigation light so as to shield the light from view at certain points of the compass as required by navigational regulations.

**light standard** - a structure on a vessel used to hold a navigation light.

**limber hole** - drain hole near the bottom of a frame or bulkhead.

**lines** the ropes or cables used on a vessel for towing, mooring, or lashing.

**loadline marks** - a set of permanent markings on the side of an ocean going or Great Lakes vessel which demotes its maximum legal operating draft under certain specified conditions and which is determined by one of the internationally recognized assigning agencies.

**lock** - an enclosure on a river or canal, with moveable, watertight gates, through which vessels pass, and proceed from one water level to another by raising or lowering the water within the lock chamber.

**logbook** - (logs) the official record of the daily operations of a manned vessel, kept in detail by the master.

**make-up** - the act of final positioning and securing of the vessels that form a tow.

**Maltese Cross** - ( @ ) A- 1 the designation used by ABS which signifies that a vessel has met the classification requirements of that agency.



## MARINE TERMS AND DEFINITIONS

**manhole** - a framed opening in the deck of a vessel which primarily provides access for a man.

**manhole cover** - a cover which seals a manhole and is usually designed to lock in place by twisting or using a centerbolt, stud bolts, or dogs.

**MARAD** - the U.S. Maritime Administration.

**marine chemist** - one who is certified to perform inspections in accordance with the Standard for the Control of Gas Hazards on Vessels to be repaired as adopted by the National Fire Protection Association.

**marine chemists certificate** - the documentation of a vessel's inspection by a marine chemist and his assignment of standard safety designations to the inspected compartments or spaces.

**master the captain of a vessel** - the person who has complete charge of and authority aboard an operating vessel.

**mats** - slabs, usually constructed of timbers, which are placed on the deck of a vessel for the purpose of supporting and distributing the weight of heavy loads.

**milemarker** - (mileboard) a marker set up to indicate distances in miles along a waterway.

**model hull** - a type of hull design in which the form is molded, curved, and shaped into a pointed stem and rounded stem.

**molded depth** - the distance from the top of the keel to the top of the upper deck beams amid ships at the gunwale.

**MRGO** - Mississippi River-Gulf Outlet; the deep draft waterway connecting the New Orleans Inner Harbor Navigation Canal to the Gulf of Mexico.

**nautical mile** - a unit of length used in sea navigation equal to 1852 meters or approximately 6076 feet.

**navigable waters** - those waterways upon which commercial or private vessels are able to operate in their customary mode of navigation.

**net tons** - the gross tons of a vessel less deductions for certain specified non-cargo spaces resulting in a net volume capacity of 100 cu. ft. per ton. (see gross tons)

**OCMI** - Officer in Charge of Marine Inspections at a U.S. Coast Guard Marine Inspection office. Such offices are located in a number of U.S. ports.

**odor threshold** - the smallest concentration, expressed in parts per million (ppm) by volume in air that can be detected by smell by most people. This is not an absolute value. It will vary among individuals and will vary from day to day for any one person. The odor of a potentially dangerous vapor may be hidden by another odor. In addition, certain vapors are likely to produce olfactory fatigue, which is deadening of the sense of smell and alone is not a reliable indicator of the presence or absence of a dangerous vapor.

**official number** - the registration number assigned by the U.S. Maritime Administration to a U.S. documented vessel and which is permanently marked on the main beam of that vessel.

**offshore waters** - a common term for those waters which are beyond inland water limits and have the technical classification of "oceans."



## MARINE TERMS AND DEFINITIONS

**pelican hook** - a hinged hook held closed by a ring and used to provide quick release of an object which it holds.

**permissible exposure limits** - (PEL); Threshold Limit Val. (TLV): the Permissible Exposure Limit and the Threshold Limit Value refer to an airborne concentration of a product expressed in parts per million (ppm) by volume in air. These are the Time-Weighted- Average (TWA) concentrations believed to be safe for the average person during an 8-hour workday and 40-hour workweek for prolonged periods. The susceptibility of individuals will vary.

**Plimsoll mark** - the primary loadline mark which is a circle intersected by a horizontal line accompanied by letters indicating the authority under which the loadline is as signed.

**poisons** - some products are classified for regulatory purposes as poisonous liquids. Definitions are given in 49 CFR PART 173, SUBPART D.

**port** - the left-hand side of a vessel when facing forward; a city having a harbor for vessels, i.e., a port hole.

**pv valve** - pressure vacuum relief valve, a valve which automatically regulates the pressure or vacuum in a tank.

**propeller** - a mechanical device having rotating blades which is mounted on a revolving, powerdriven shaft for the purpose of propelling a boat; also called a screw or wheel.

**pushboat** - a highly maneuverable, inland waters, shallow draft towboat usually designed with a square bow and towing knees which facilitate its primary method of towing, which is pushing.

**push knee** - (towknee) a vertical, reinforced steel structure installed on a vessel to facilitate push towing. The height of the knee allows for variance in freeboards between vessels.

**raised rake** - the rake of a barge which has sheer.

**rake** - the configuration of the square end of a barge or boat in which the bottom slopes upward to meet the headlog or sternlog.

**reachrod** - a steel rod which connects an above deck valve handle to a below deck valve.

**registered** - pertaining to certain vessel data calculated under specific rules and officially documented, such as registered length.

**reid vapor pressure** - equilibrium pressure exerted by vapor over the liquid at 100°F, expressed as pounds per square inch absolute (pisa) defined in 46 CFR 30.10-59.

**rubrail** - a protective railing on the hull of a vessel which is used for fendering.

**Rules of the Road** - a code governing vessels as to the lights to be carried, the signals to be made, and their safe and proper navigation in order to avoid collisions. Statutes of the United States provide varying regulations for three areas of navigation. These regulations are known as Western River Rules, Inland Rules, and International Rules.



## MARINE TERMS AND DEFINITIONS

**running lights** - those lights required to be shown at night aboard a vessel or a tow while underway.

**sailing line** - the preferred course for safe and efficient navigation in the channel of a water way.

**scow** - another term for a deck cargo barge having a hull design of a flat bottom, square ended rakes, and usually with a deck cargo bin.

**scupper** - a drainage opening cut flush with the deck of a vessel through the bulwark or bin wall.

**seaworthy** - the reasonably staunch, sound, and fit condition describing a vessel's capability to safely carry its cargo and complete its intended voyage or use.

**semi-integrated barge** - a barge which is raked at one end and boxed at the other end.

**shackle** - a u-shaped metal fitting used as a connection for line, cable, or chain and which has a pin secured through its end by a nut, cotterpin, or screw threads.

**sheer** - the upward curvature or angle of a vessel's deck at the bow or stern.

**shifting** - the short movement or transfer of a vessel within a harbor or mooring area.

**short exposure tolerance** - vapor concentration, expressed as parts per million (ppm) by volume in air, which should not be exceeded for the exposure times specified. Other exposure information obtained from sources believed to be reliable is included. In many cases little or no data on human exposure are available.

**skag** - (skag) a framed steel plate structure which acts as a fixed rudder under the stern rake of a barge; also, the after part extension of a boat's keel upon which the rudder rests.

**slopesheet** - the sloped vertical steel plate forming the end of the hopper barge cargo compartment and which is part of the rake bulkhead.

**specific gravity** - this is the ratio of the weight of a volume of the cargo to the weight of an equal volume of water. In the case of liquids of limited solubility, the specific gravity will predict whether the product will sink or float on water; for example, if the specific gravity is greater than 1, the product will sink, and if the specific gravity is less than 1, the product will float.

**sponson** - an addition to the side of a vessel that is outside its normal hull and which provides added deck space and/or greater flotation stability.

**spud** - a steel or wooden post or pile that is placed vertically through a well in the hull of a vessel and which, when lowered to the bottom of the waterway, anchors the vessel.

**spudwell** - a casing which is attached to or passes through the hull of a vessel through which a spud is raised or lowered.

**starboard** - the right-hand side of a vessel when facing forward.

**steamboat ratchet** - a sleeve, internally threaded at the ends and with attached eye-rods, equipped with a ratchet used to turn the sleeve, thereby pulling the rods towards each other.

**stem** - the main vertical structural member which forms the foremost part of a boat's model bow.



## MARINE TERMS AND DEFINITIONS

**stern** - the after or rear end of a vessel.

**sternlog** - the reinforced, vertical shell plating which connects the stern rake bottom to the rake deck of a barge.

**strake** - a longitudinal or transverse row of steel hull plates.

**superstructure** - the structural part of a boat above the main deck.

**survey** - a critical examination or inspection of a vessel, cargo, or marine structure for the purpose of ascertaining desired facts and conclusions when necessary.

**survey, condition** - determines in some detail the specific condition of a vessel or of cargo; usually performed at the commencement or termination of charters or voyages for the agreed mutual benefit of various parties.

**survey, damage** - determines the exact extent of damages incurred and specifies repair requirements.

**survey report** - the written evidence of the survey.

**survey, suitability** - determines whether a vessel and its equipment are capable of adequately and safely performing an intended task.

**survey, trip and tow** - a survey in which the surveyor has full responsibility for inspecting and approving the suitability of the towing vessel, its gear and its tow, the loading and lashing of the cargo, and the navigational procedures, all in relation to the trip intended.

**survey, valuation** - determines the current market value and may also express replacement value.

**surveyor** - a qualified marine inspector who performs surveys.

**tank** - an enclosed space used for holding liquids.

**time charter** - a contract for the services of a vessel for a specified period of time during which the primary control and management of the vessel remain with the owner.

**tow** - to push or pull vessels on a waterway; also refers to the unit comprised of the towing vessel and the vessels being towed or only the vessels being towed.

**towboat** - any powered vessel which is used for towing.

**transom** - the hull plate and its framing that form the vertical end of a box-shaped barge; also, the framed plate forming the stem of a square-ended boat.

**truss** - a rigid framework of horizontal, vertical, and diagonal structural members designed to support loads and reinforce a vessel's hull.

**tugboat** - a model hull towboat of relatively deep draft used primarily for pull towing and designed for navigation in open or unprotected water.

**turnbuckle** - a connection device usually used with cable or chain and which takes up slack by rotating on its screw threads.

**ullage opening** - a small, covered opening in the top of a cargo tank through which measurements are made to determine the level of the liquid in the tank.



## MARINE TERMS AND DEFINITIONS

**U.S.C.G.** - The United States Coast Guard

**vapor density** - this is actually a specific gravity rather than a true density because it equals the ratio of the weight of a vapor or gas (with no air present) compared to the weight of an equal volume of air at the same temperature and pressure. Values less than 1 indicate that it tends to settle. However, temperature effects must be considered. For example, although methane at 68°F has vapor density of 0.55, it becomes more dense at lower temperatures. At -259°F, the boiling point, the vapor is heavier than air. Vapors from an open container of boiling methane fall rather than rise.

**vapor pressure** - the equilibrium pressure of the saturated vapor above the liquid, measured in millimeters of mercury (760 mm Hg = 14.7 psia) at 20°C (68°F) unless another temperature is specified.

**VCG** - Vertical Center of Gravity; an important computation used in the determination of the stability of a vessel with its cargo.

**VTC** - Vessel Traffic Control; a central control system used in some ports to safely direct navigation.

**watertight** - of such construction or fit as to prevent the passage of water, except when structural discontinuity, physical rupture, or purposeful opening may occur.

**wheel** - another term for propeller; also, a boat's steering wheel.

**WHL** - West of Harvey Lock; used with mileage designations on the Gulf Intracoastal Waterway, Harvey Lock being mile zero.

**WQIS** - Water Quality Insurance Syndicate; an underwriting agency formed by various insurance companies for the purpose of insuring against losses resulting from water pollution.

**NOTE:** The preceding terminology is defined as it is used in the shallow draft boat and barge industry in the United States. For complete information regarding requirements or regulations of governmental or private agencies, we recommend direct contact with those agencies.

## BARGE SYSTEMS, PARTS AND FIELD SERVICE

ERL manufactures all components required for complete barge equipment packages, including the required regulatory signs! With extensive field service and parts support, ERL is the only vapor recovery and overfill protection equipment manufacturing source offering complete single source capability. We offer parts and service not just on ERL equipment, but on all makes of tank barge equipment.

Our service technicians are always available. They are dispatched from field locations throughout the Midwest and Gulf South to ensure prompt response times. Phone 800-831-9510 to receive complete service capability information or to receive help the next time you have a parts or service need.



If you have recurring maintenance problems or needs and you have an idea for a new product or improvement to existing products, we would really like to hear from you.

**ERL - turning IDEAS into PRODUCTS which serve our industry better.**



## **ERL VAPOR RECOVERY TRAINING BARGE**



### **• ONSITE TRAINING**

ERL can provide on site practical hands-on equipment training, which covers all tank barge equipment that relates to: Gauging, Overfill Protection and Venting.

The ERL training barge has a Vapor Header, four types of P-V Valves, P-V Gauge, Expansion Dome with two types of Sight Glasses and Gauge Trees, Rising Stick Gauge, two types of High Level and Overfill Alarms that function with onboard Alarm Panel and barge to shore connection, two Spill Valves, Regulatory Signs and two Reach Rod assemblies complete with Stuffing Boxes and Valve Position Indicators.

**CALL ERL TODAY TO SCHEDULE THIS IMPORTANT TRAINING  
FOR YOUR PERSONNEL.**





## INDEX

10LS AND 12LS BARGE PUMP DESIGN .....	173
10LS AND 12LS BARGE PUMP PERFORMANCE.....	177
10LS AND 12LS BARGE PUMP TESTING .....	175
10LS DEEPWELL VERTICAL TURBINE TANK BARGE PUMP .....	171
12LS DEEPWELL VERTICAL TURBINE TANK BARGE PUMP.....	170
12LS OFFSHORE BALLAST WATER VERTICAL PUMP .....	172
4" ROUND SIGHT GLASS.....	5
40 TON WINCH OPERATING INSTRUCTIONS .....	112
40 TON WINCH OVERALL DESIGN DIMENSIONS.....	111
8" ROUND SCRAPER SIGHT GLASS .....	4
AIR BOX DRAIN CANISTER.....	165
API RECOMMENDED PRACTICE 1125 .....	41
APM-2-E FIXED ALARM PANEL.....	71
APM-2-F-APA ANTI POLLUTION ALARM .....	194
APM-2-F-APA ANTI POLLUTION ALARM.....	66
APM-3 .....	72
BARGE SPILL KIT RACK.....	160
BARGE SYSTEMS, PARTS AND FIELD SERVICE.....	208
BARGE TO SHORE CONNECTION BTS ASSEMBLY DRAWINGS.....	52
BOLT ON WIRE ROPE BUTTON EWB-1 .....	108
BOLT ON WIRE SWAGE HOLDER .....	107
CARGO CLEANING DIFFUSER.....	150
CARGO GRADES .....	196
CARGO PUMP CATCH CAN .....	153
CARGO VALVE POSITION INDICATORS.....	121
COMPANION FLANGE.....	191
CONTROL VALVE OPERATING SYSTEM.....	123
CONVERSION FACTORS.....	197
DECK STAND – LASER ALIGNMENT TOOL KIT .....	143
DECK STANDS.....	115
DESCRIPTION OF THE 40 TON WINCH.....	109
DESCRIPTION OF THE PV-6 II .....	80
DOCUMENT BOXES .....	162
DRAFT MARKS.....	31
DRIP PANS .....	154
DRIVESHAFT-LASER ALIGNMENT TOOL KIT.....	193
DRIVESHAFT-PTO TO RIGH ANGLE DRIVE.....	192
DRY BOX.....	152
DRY BOX – PIPE MOUNT .....	149



## INDEX

EQUATE(TM) SERIES 2.5" PV VALVE.....	88
EQUATE(TM) SERIES 4" PV VALVE .....	92
EQUATE(TM) SERIES 8" PV VALVE.....	96
ERL FOUR SCREW VERTICAL TANK BARGE PUMP.....	180
ERL MODEL SGMRD-8™ .....	15
ERL VAPOR RECOVERY TRAINING BARGE.....	209
EXCERPTS FROM FEDERAL REGISTER.....	38
EXCERPTS FROM FEDERAL REGISTER.....	78
FIRE EXTENGUISHER HOLDERS .....	163
FIXED ALARM PANELS APM-2 .....	60
FLEXI-DIP .....	33
FUEL TANKS .....	159
FULL VIEW MODEL SGM-1™ .....	6
FULL VIEW MODEL SGM-2™ .....	14
HANDWHEELS.....	127
HIGH LEVEL/OVERFILL LIQUID LEVEL ALARM SENSORS.....	43
HIGH LEVEL/OVERFILL TABS.....	31
HIGH VELOCITY PRESSURE/VACUUM RELIEF VALVE .....	79
HOSE RACK.....	164
KEY DESIGN FEATURES.....	110
LADDERS.....	156
LIP SEAL STUFFING BOXES.....	141
MARINE CAM HANDLE SCUPPER PLUG .....	140
MARINE FLAME SCREENS.....	100
MARINE SCUPPER PLUG.....	114
MARINE SCUPPER PLUG.....	161
MARINE TERMS AND DEFINITIONS .....	198
MECHANICAL SEAL .....	181
MODEL DS-39 RISING STICK GUAGE.....	24
OPERATION OF THE PV-6 II.....	82
OUTER BEARING ASSEMBLY (OBA).....	189
OUTER BEARING ASSEMBLY FIXED (OBAF).....	187
OUTER BEARING ASSEMBLY SLEEVED (OBAS).....	185
OVERLOW TANK.....	148



## INDEX

PORTABLE ALARM PANEL MODEL APM ITLB.....	59
PORTABLE ALARM PANEL MODEL APM-1B .....	58
PORTABLE ALARM PANEL MODEL APM-1B LITE .....	57
PORTABLE GUAGING SYSTEMS .....	32
PRESSURE/VACUUM VIBRAGUAGE.....	145
PROTECTED FLAME SCREEN VENT (EPV).....	101
PUMP PURCHASE REQUISITION .....	179
PV-6 II PERFORMANCE .....	86
RADIAL ARM GUAGE TREE <sup>TM</sup> .....	17
REACH RODS .....	124
REGULATORY SIGNS.....	132
REPRINT OF 46 CFR PART 39 Subpart 39.20 .....	3
ROD-TO-ROD COUPLERS.....	128
RSA-LEVEL ALERT RISING STICK ARM.....	23
SAMPLER BALL VALVES .....	32
SHAFT COUPLING .....	183
SHAFT HANGERS.....	129
STAINLESS 40 TON WINCH – 100” CAPACITY – TANK BARGE.....	104
STAINLESS 40 TON WINCH – 50” CAPACITY – HOPPER BARGE.....	106
STAINLESS 40 TON WINCH – 50” CAPACITY – TANK BARGE .....	105
STEM ADAPTERS .....	126
STUFFING BOX – LASER ALIGNMENT TOOL KIT INSTALLATION .....	144
SUPERAC(TM) MODEL PV-6 II.....	84
SUPERAC <sup>TM</sup> 12” ROUND MARINE SAFETY RELIEF VALVE .....	73
SUPERSEAL <sup>TM</sup> STUFFING BOX.....	119
SUPERSEAL <sup>TM</sup> REACH ROD STUFFING BOX.....	117
TANKERMAN'S SHED.....	167
TELESCOPIC PEEP LIGHT .....	166
TESTING OF THE ERL PV-6 II .....	83
THROTTLE CONTROL HANDLE .....	151
TYPICAL SERIES WIRING DIAGRAMS.....	53
U-JOINT .....	142
VAPOR CONTROL VALVES .....	33
VENT STACK .....	102
VENT STACK .....	155
VHSG(TM) VENT HEADER SIGHT GLASS .....	21
YOKES .....	130